



V2-45

THE NEW V2 SERIES LIFTGATE FOR BOX TRUCK APPLICATIONS

THE ALL NEW **V2**
SERIES

RELIABILITY DELIVERED

QUALITY PRODUCTS, DEPENDABLE SERVICE, TRUSTED PARTNER

TOMMYGATE.COM/LIFTGATES/FLATBED-AND-VAN

NEW

TOMMY GATE® V2 SERIES

1,100 LBS
CAPACITY



CAPACITY:
1,100 LBS.



PLATFORM SIZE:
47 x 49



LIFT LOCATION:
INTERNALLY
MOUNTED



FULLY-AUTOMATIC:
HANDS-FREE PLATFORM
OPEN AND CLOSE

V2 SERIES

The New Internal Van Body Lift

The latest in liftgate technology, the V2 Series by Tommy Gate provides the maximum platform loading area while occupying the smallest possible space when stored in the rear of the van body. The V2 combines sleek modern engineering with hands-free platform open and close, built-in wheeled retention ramp, and 1,100lbs. of lifting capacity.

SCAN FOR VIDEO



TOMMY GATE®

2-YEAR STANDARD WARRANTY



SCAN FOR MORE INFO



Standard Features

- 1 RETENTION RAMP**
 Dual-action retention ramp is designed for convenient foot activation at ground level as well as hand activation at bed height, making it easy to load wheeled cargo.
- 2 TWO-FUNCTION CONTROL**
 Pendant control with raise/lower toggle and secondary platform fold function.
- 3 ALUMINUM TREADPLATE BRIDGE**
 The Aluminum treadplate bridge provides a smooth transition for moving cargo to and from lift platform to vehicle bed.
- 4 LOW-PROFILE PUMP BOX**
 Pump and motor housing fits compactly over the wheel well.
- 5 FLAT-LOADING TAPER**
 Platform rests flat at ground level, minimizing load angle.

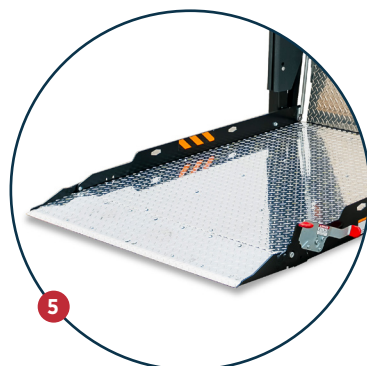
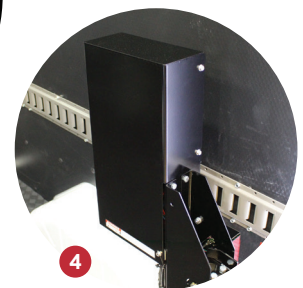

2-YEAR STANDARD WARRANTY

Available Models

	Model Number	Load Area	Taper	Travel ²	Gate Weight
1100 lb.	Framed Aluminum Platforms				
	V2-56-1145 FA49¹	47 x 49	9	45	480

NOTES

1. FA49 Models must have the 9" retention ramp/taper engaged when storing the platform on lower roof models to avoid the ramp contacting the van frame.
2. Unladen bed-height cannot exceed 45" travel.
3. Provided brackets are intended to be building blocks to mount a V2 liftgate to a flat floor body. Modification to these parts and/or additional parts may be required.

IMPORTANT

- There are numerous truck configurations and body styles. Check the clearance of the liftgate with any bumpers or additional equipment on the back of the truck.
- V2 Series liftgates reduce the door opening height by 2" (from the metal floor).

SIDE VIEW

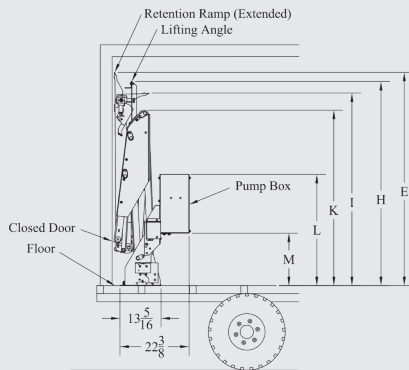

TOP VIEW

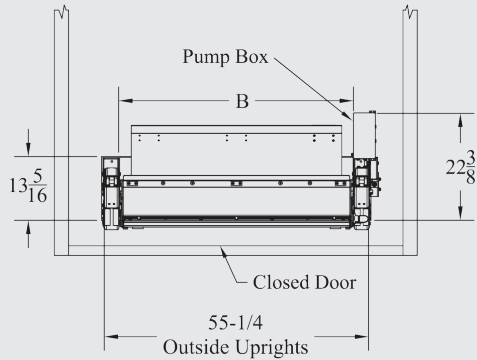

CLEARANCE

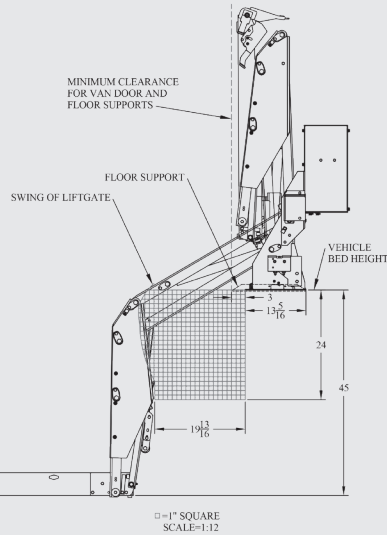

THE TOMMY GATE® FACTORY IS PROUDLY LOCATED IN WOODBINE, IOWA, USA.



Woodbine Manufacturing Inc.
83 Bus Brown Drive
Woodbine, IA 51579

TOMMY GATE® LIFTGATES
(800) LIFTGATE
TOMMYGATE.COM

SCAN FOR MORE INFO

