

650 Series Cargo Van Lift Mounting Instructions

Ford Transit (High Roof)
2015-Present

13914

Installing the Base Plate

- 1. Examine** the interior and exterior of the van for possible obstructions such as rear air conditioning, heater vents, electrical wiring, spare tire, etc (Figure 2).
- 2. Examine** the underside of the van for obstructions that could be damaged when drilling through the van floor: fuel tank, frame rail, spare tire, wiring, etc (Figure 2 and 3).
- 3. Verify** that the bed height of the van is not over 31-1/2".
- 4. Verify** that mounting bracket kit matches (Figure 1 and Table 1) and that this kit is for your van.

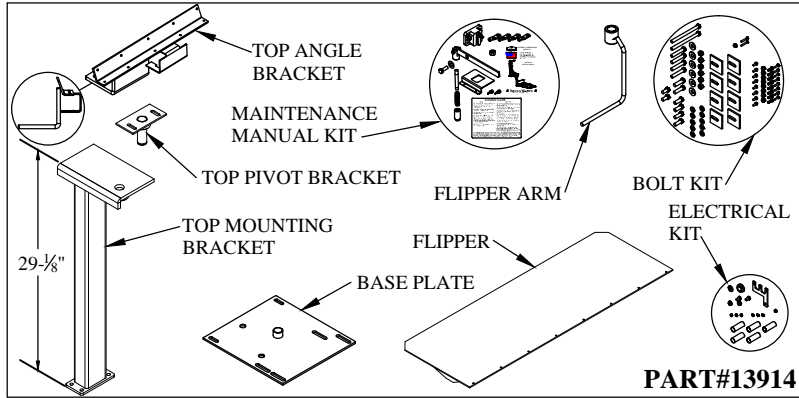

Figure 1: Part Identification.

Table 1: Parts List.

QTY.	PART NO.	DESCRIPTION
1	1094	650 Bolt Bag Kit
1	13913	Top Angle Bracket (Transit High Roof)
1	2424	Top Pivot Bracket (Ford)
1	1615	Top Mounting Bracket (Sprinter High Roof)
1	1464	Flipper
1	1473	Flipper Arm (650-31)
1	1386	650 Base Plate
1	1062	Maintenance Manual Kit (650)
1	14122	Ford Transit Electrical Kit

- 5. Position** the base plate in the van as described in notes A or B (Figure 3). The base plate should be parallel with the floor ribs, not the van doors.

Note A: The base plate can be located 13-1/4" from the rear inside left wall of the van and 4-1/2" back from the metal part of the closed door on the right side of the base plate.

Note B: The base plate can be located 9-1/2" from the rear inside left door opening of the van and 4-1/2" back from the metal part of the closed door on the right side of the base plate.

- 6. Position** the square washer plates under the base plate between the floor ribs, if needed. The area around the mounting holes must be properly supported by the metal floor.

- 7. Check** for obstructions before drilling in the next step.

- 8. Drill** holes through the floor for the base plate, using the base plate slots as a guide. Pay close attention to which slots in the base plate to use. The rear two bolts do not go all the way through the rear cross member.

- 9. Bolt** the base plate to the vehicle floor using the hardware provided. There are access holes in the bottom of the rear cross member for the rear two bolts (Figure 4).

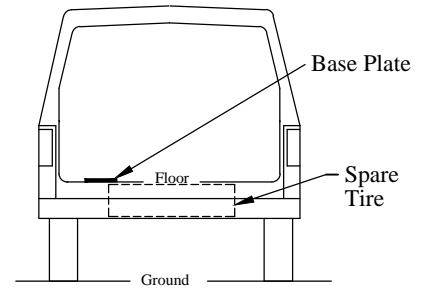

Figure 2: Base plate location and obstructions.

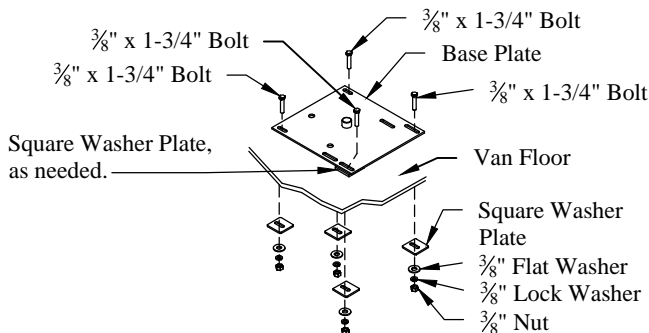

Figure 4: Base plate hardware.

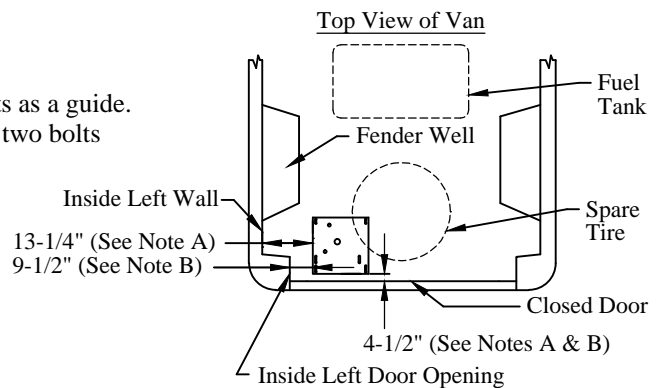

Figure 3: Base plate location and obstructions.

Installing the Top Mounting Brackets

1. **Install** the swing release latch assembly (Figure 5). This must be done before mounting the liftgate.
2. **Remove** any plastic trim which is in the way of the upper support parts.
3. **Support** the lift to keep it from falling in the next steps.
4. **Attach** the top mounting bracket with the 3/8" x 1" bolts and lock washers (Figure 6).
5. **Attach** the top pivot bracket to the top angle bracket with the supplied 3/8" bolts, flat washers, lock washers, and nuts (Figure 7). Apply blue LockTite® Thread Locker or equal to the bolts before tightening.

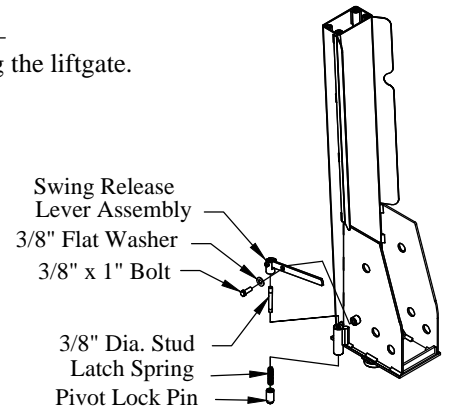

Figure 5: Swing release latch.

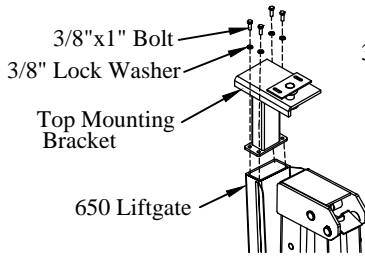

Figure 6: Top mounting bracket.

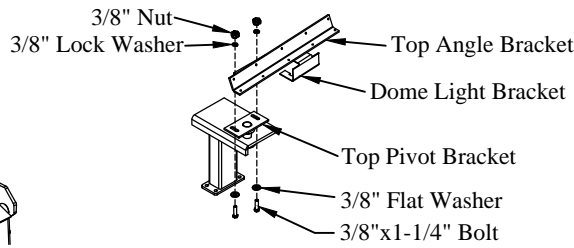

Figure 7: Top angle bracket.

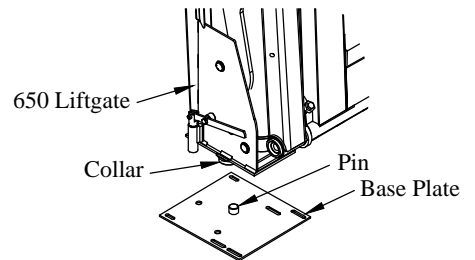

Figure 8: Base plate pin location.

Mounting the Liftgate in the Van

1. **Support** the liftgate securely to keep it from tipping while performing the next steps.
2. **Position** the liftgate collar onto the base plate pin (Figure 8).
3. **Position** the liftgate in the rear opening such that the top angle bracket comes in contact with the rear door header (Figure 9).
4. **Install** the vehicle dome light in the bracket provided on the top angle bracket.
5. **Position** the liftgate so it is tipped 3 degrees back and 1 degree to the left (Figure 10).
6. **Tighten** all hardware.
7. **Hold** the top angle bracket against the rear door header.
8. **Locate** and **Drill** eight (8) 5/16" holes into the rear door header, using the top angle bracket as a guide. Choose eight (8) of the angle bracket holes without obstructions.
9. **Assemble** the Plusnut with the 1/4" crown lock nut and 10-32 x 1-1/4" hex bolt (Figure 11)
10. **Insert** the Plusnut into the 5/16" drilled hole (Figure 12).
11. **Tighten** the hex bolt while holding the 1/4" nut (Figure 13). Fully upset Plusnut provides mounting nut to attach the top angle bracket (Figure 14).
12. **Attach** the top angle bracket to the header using the supplied 10-32 x 3/4" hex bolts. Apply blue LockTite® Thread Locker or equal to the bolts before tightening.

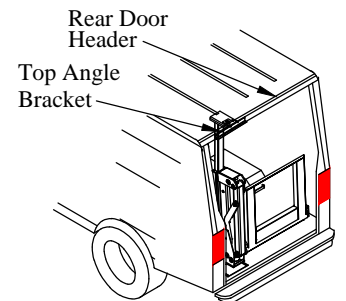

Figure 9: Liftgate in rear opening.

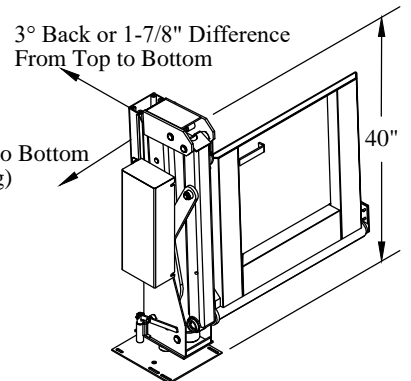

Figure 10: Liftgate properly tipped.

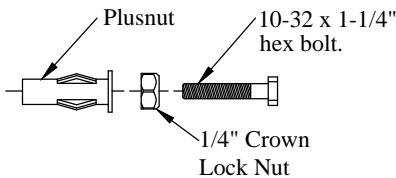

Figure 11: Plusnut Parts.

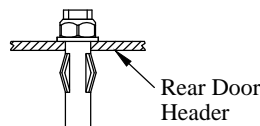

Figure 12: Assembled Plusnut.

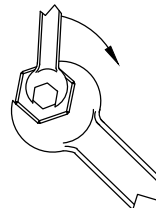

Figure 13: Plusnut tightening.

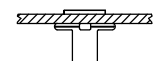

Figure 14: Fully upset Plusnut.

Mounting the Liftgate in the Van (continued)

13. **Push** down on the swing release lever (Figure 15).
This will unlock the release pin allowing you to rotate the complete liftgate.
14. **Verify** that the swing release pin will latch in both the stored and operational positions.
15. **Loosen** the four (4) pump box bolts (Figure 16).
The bolts do not need to be removed.
16. **Remove** the pump box cover (Figure 16).
17. **Remove** the solid plastic shipping plug from the reservoir (Figure 16).
18. **Install** the vent plug. Failure to change the plug will damage the reservoir.

Note: The hydraulic system has been filled with the proper amount of oil, do not add any at this time.

Note: Pump and motor unit must remain vertical during operation, or it will be damaged.

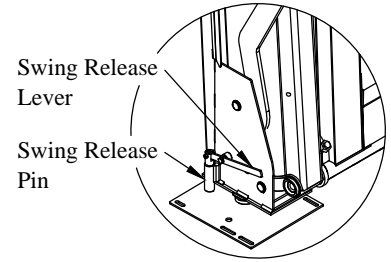

Figure 15: Swing release feature.

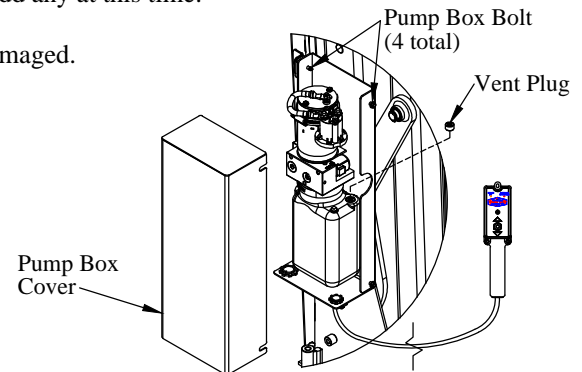

Figure 16: Pump and motor unit.

Routing the Power Cables

Note: 2020+ Ford Transit

Connect the liftgate positive cable directly to the battery, not the Customer Connection Points (CCP) for these model years of Transit. Electrical loads controlled by the van's load-shed signal, such as the CCP, may temporarily be turned off by the load-shed switch while the liftgate is operated.

Note: 2015-2019 Ford Transit

Ford recommends using the vehicle Customer Connection Points (CCP) to power the liftgate. Vehicle option 67C-User Defined Upfitter Switches, provides three (3) 60 amp CCP, which can be combined into one 180 amp connection. If three (3) CCP are not available, Ford part number BK2Z-14S411-A adds the additional CCP. If neither of these options are available, large loads can be connected to an empty M6 stud on the positive battery terminal using the supplied M6 lock nut (Ford Bulletin Q-226R2).

1. **Install** the circuit breaker on the floor behind the driver seat, near the battery, leaving enough room for the power cables to be installed and so that the circuit breaker can easily be reset.
2. **Check** for obstructions before drilling.

Note: Any time a hole is drilled in the vehicle, apply rust preventative to the bare metal.

3. **Drill** and **Deburr** a hole in the van floor, near the power unit, to run the power cables through.
Use a rubber grommet to protect the power cables from the sharp sheet metal edge of the drilled hole.
4. **Drill** and **Deburr** a 1-1/4" hole in the floor next to the driver seat in the location shown (Figure 17).
An alternate location will be needed if there is a trailer brake controller in the way.

Note: Follow the *Tommy Gate Recommended Electrical Wiring Guidelines* and wiring diagram (Figure 21) in the following steps.

5. **Route** the power cables under the vehicle from the liftgate, along the frame, to a location under the driver door (Figure 18).
Provide at least 12" extra of cable near the pump to allow for gate movement and for later service.

Routing the Power Cables (continued)

6. **Pull** the power cables through the drilled 1-1/4" hole in the floor, using the supplied grommet.
7. **Separate** the positive(+) and negative(-) leads.
8. **Cut** the positive(+) lead to the length required to reach the auxiliary (AUX) terminal of the circuit breaker.
9. **Cut** the remaining positive(+) lead long enough to reach from the circuit breaker battery (BAT) terminal to the positive 12 volt connection point for your application (see notes at beginning of this section).
10. **Cut** the negative(-) lead to the length required to reach a vehicle ground point on the floor between the front seats (Figure 17).

IMPORTANT: The pump and motor unit for this lift can require significant electrical power at 12 volts D.C.
Be sure that the negative (-) ground lead is securely connected to a sufficient vehicle ground point.

11. **Install** the copper lugs on all required ends. Make sure the copper lugs will fit flush with the connection surfaces.
12. **Connect** the negative(-) lead to a vehicle ground point on the floor between the front seats. (Figure 17).
13. **Connect** the circuit breaker (Figure 21). Use the supplied heat shrink tubing.
14. **Check** for obstructions before drilling.
15. **Attach** the circuit breaker cover using the supplied self-drilling screws (Figure 19).

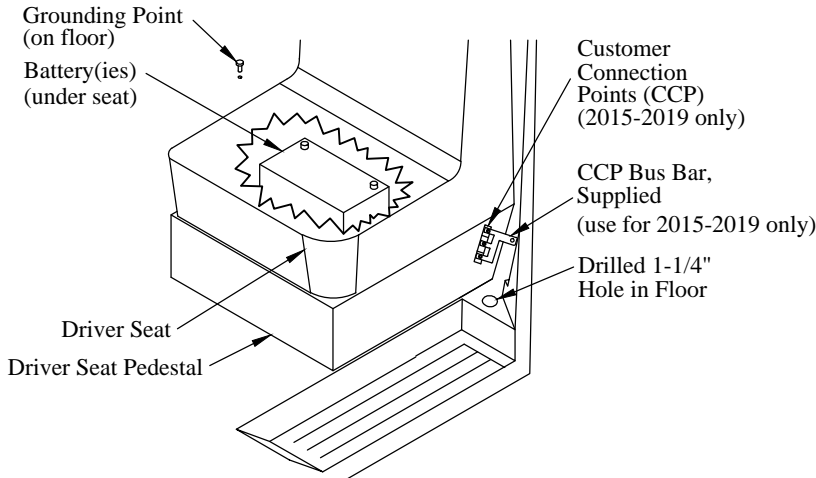

Figure 17: Customer Connection Point location.

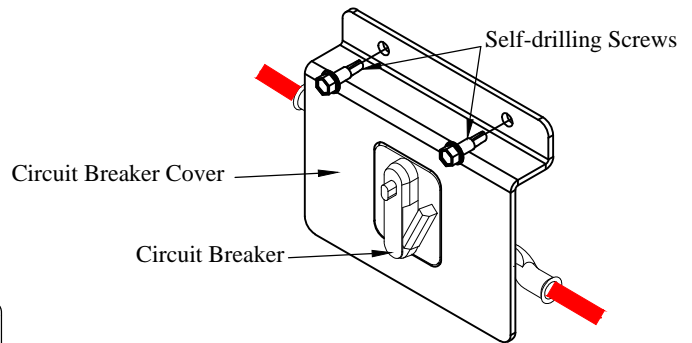

Figure 19: Circuit breaker cover.

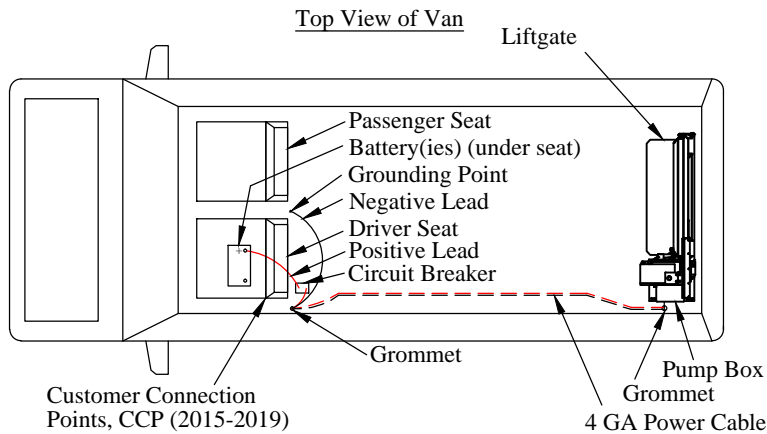

Figure 18: Electrical routing.

Routing the Power Cables (continued)

16. **Connect** the positive(+) lead to the M6 stud on the positive battery clamp. Reuse the M6 lock nut, when possible (Figure 20).
For 2015-2019, see Ford Bulletin Q-226R2 and do not connect to the stud occupied by the alternator sensing circuit.
17. **Apply** sealant to holes drilled for power cables.
18. **Skip** Steps 19-22 for 2020+ Transit.
Complete Steps 19-22 only if using the CCP bus bar for 2015-2019.
19. **Remove** the plastic cover from the CCP on the driver seat pedestal (Figure 17).
20. **Install** the supplied bus bar on the CCP studs using three (3) supplied M5 nuts and star washers.
The bus bar combines three (3) 60 amp connections into one 180 amp connection point.
21. **Connect** the positive(+) lead to the CCP bus bar. Use the supplied 5/16" bolt, lock nut, and two (2) pieces of heat shrink tubing to cover the cable connection to the bus bar.
22. **Install** the plastic CCP cover on the bus bar cable connection. The cover will need to be trimmed for bus bar clearance.
23. **Push** the hidden "Power On" switch (Figure 21). The amber "Power On" LED will illuminate.
24. **Push** the hidden "Liftgate Activated" switch twice within one second. The red "Liftgate Activated" LED will illuminate.

Note: With both lights on, the liftgate can be raised or lowered. If not used for 90 seconds, the control will automatically shut off.

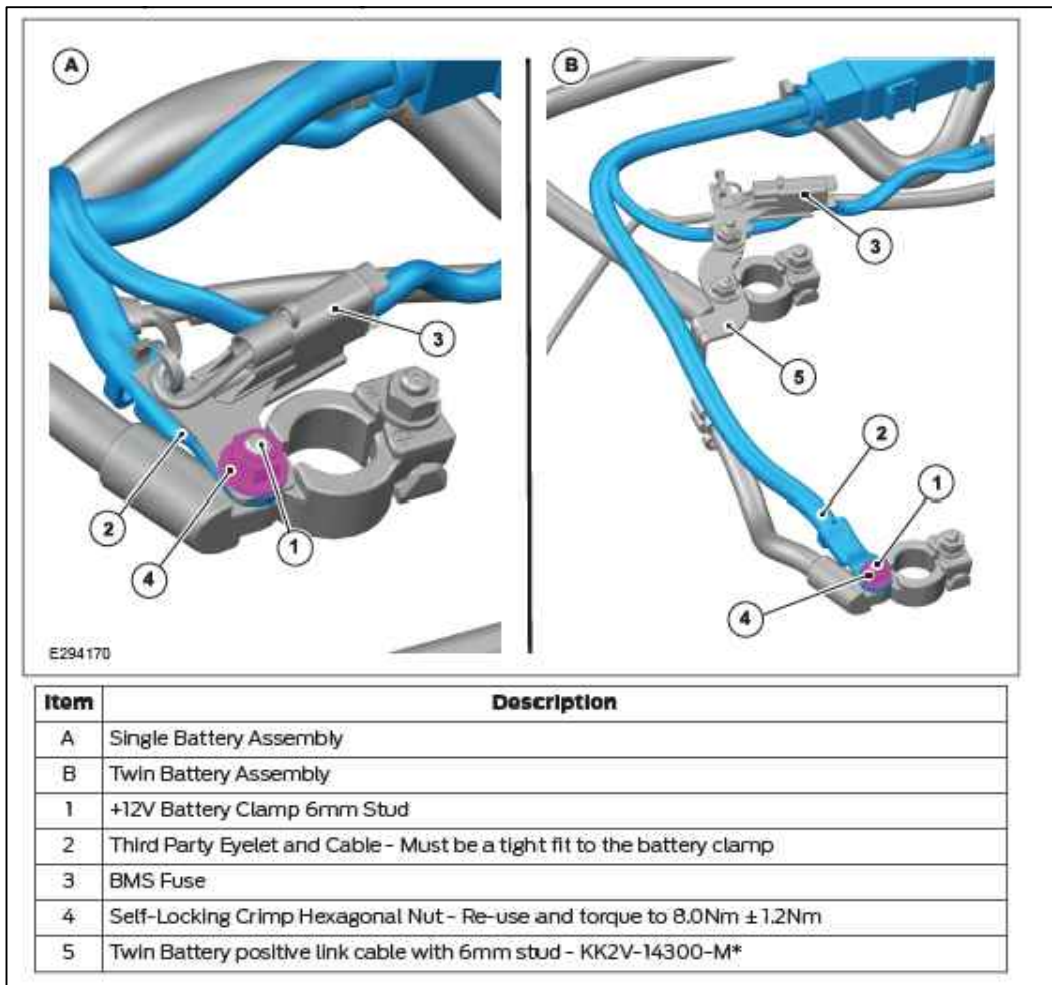

Figure 20: Battery diagram from 2020 Ford Transit Body and Equipment Mounting Manual (BEMM).

Routing the Power Cables (continued)



!!! PLEASE READ AND FOLLOW ALL DIRECTIONS BEFORE PROCEEDING !!!

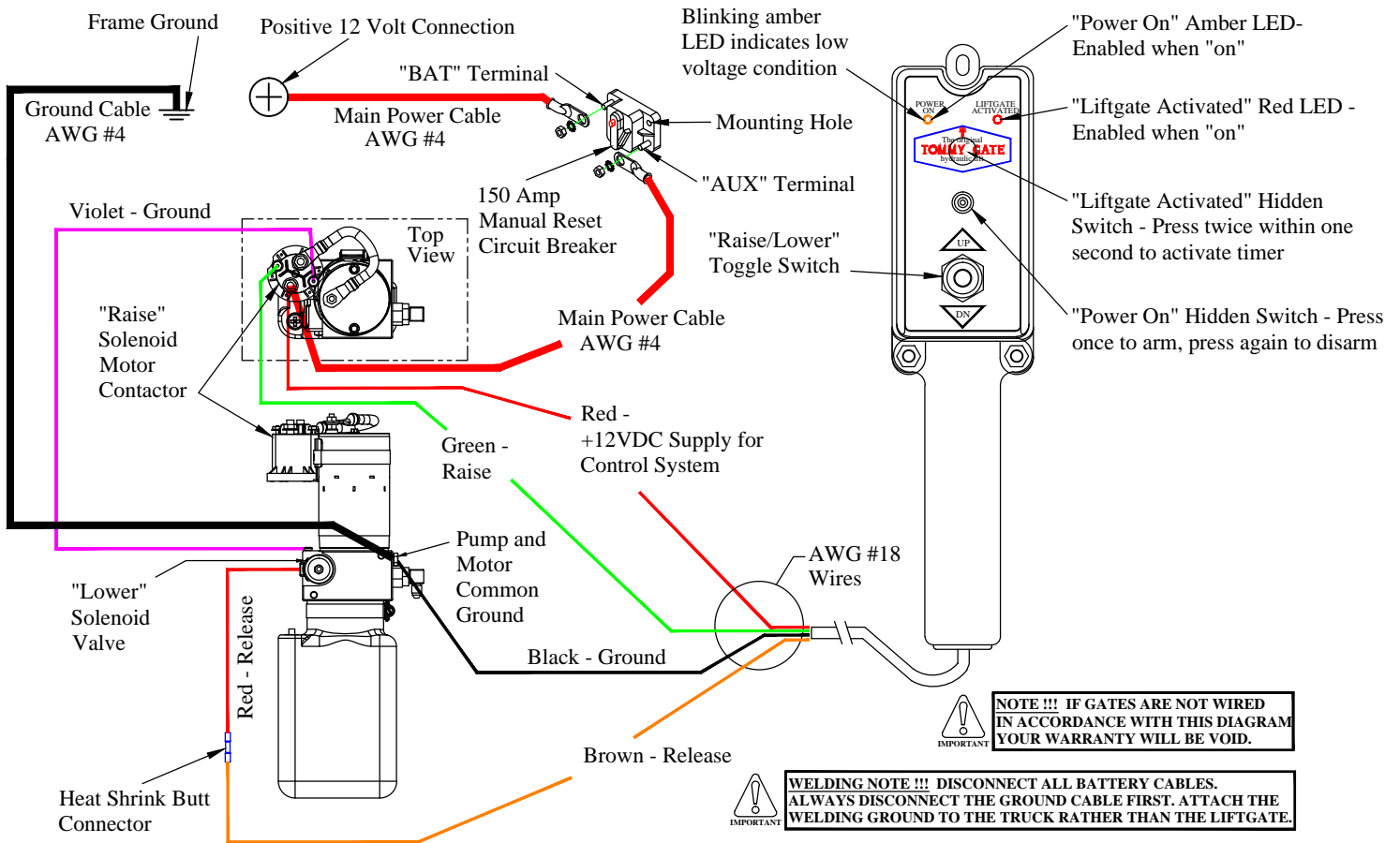

Figure 21: Wiring Diagram.

Routing the Power Cables (continued)

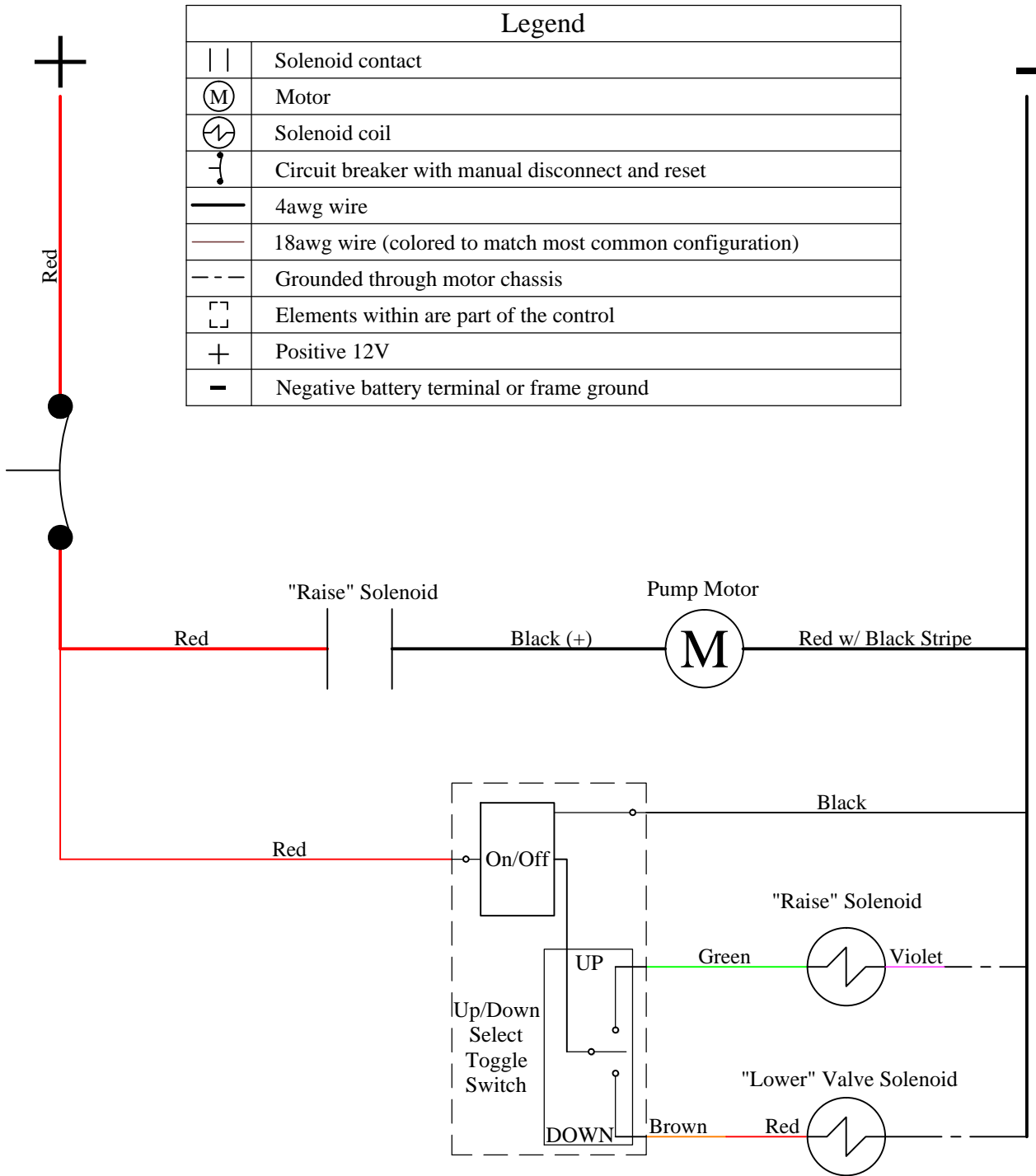

Figure 22: Power unit control circuit.

Installing the Flipper Kit

1. **Verify** proper liftgate operation.
2. **Loosen** the jam nut (Figure 23).
3. **Completely** tighten the adjustment bolt.
4. **Lower** the gate until it contacts the ground.
The taper edge of the platform may not contact the ground at this point.
5. **Loosen** the adjustment bolt until the taper edge of the platform contacts the ground.
6. **Tighten** the jam nut.
7. **Remove** the 3/8" x 1-1/4" bolt weldment that holds the self-closing arm to the platform (Figure 24).
8. **Remove** the rod from the tube (Figure 25).
9. **Install** the flipper arm over the self-closing tube (Figure 26).
10. **Tighten** the 1/4" set screw on the flipper arm (Figure 26).
11. **Reinstall** the self-closing rod and 3/8" x 1-1/4" bolt weldment (Figure 27).
12. **Attach** the flipper to the hinge on the platform using eight (8) 8-32x1/2" screws and 8-32 nylon lock nuts (Figure 28).
13. **Raise** the platform to bed height.
14. **Loosen** the set screw on the flipper arm.
15. **Adjust** the flipper arm up or down until it just touches the bottom of the flipper when the flipper rests on the van floor.
16. **Tighten** the set screw.
17. **Verify** that the flipper has no obstructions and clears the bumper when raising and lowering the liftgate.

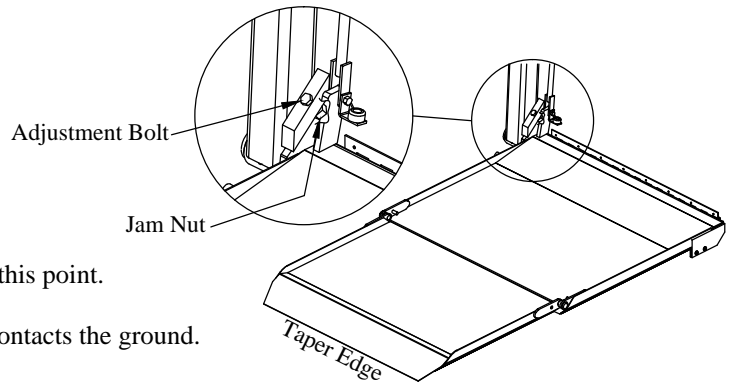

Figure 23: Unfolded 650 platform.

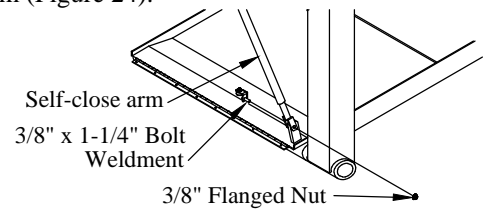

Figure 24: Self-close arm parts.

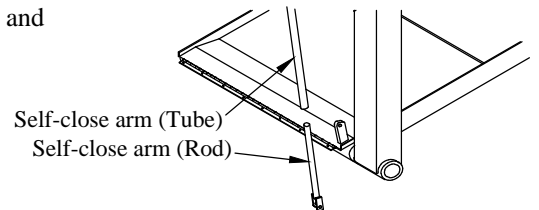

Figure 25: Self-close arm parts.

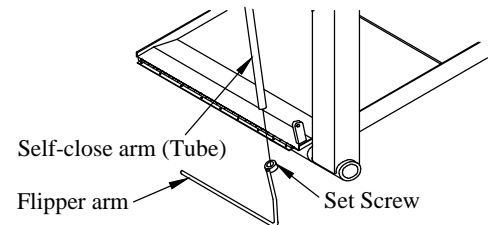

Figure 26: Flipper arm location.

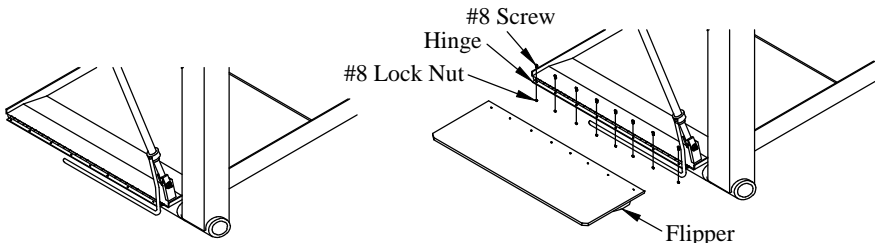

Figure 27: Flipper arm assembled.

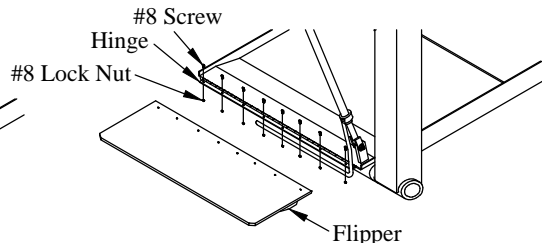

Figure 28: Flipper hinge hardware.

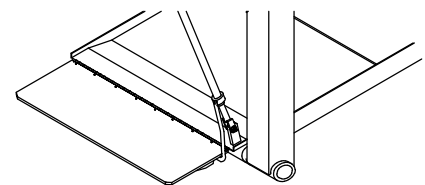

Figure 29: Flipper installed.

Finishing the Installation

1. **Test** the liftgate unloaded and at rated capacity for proper operation.
2. **Demonstrate** the proper operation to the operator.
3. **Provide** the owner/operator's manual and "Do's and Do Not's" decal to the operator, or place them in the vehicle.

WIRE ROUTING

- (1) When routing wires, avoid heat (above 180°F), abrasion, vibration, metal edges, screws, and trim fasteners. If such routings are not possible, protective devices must be used. If wires must cross a metal edge, the edge should be covered with a protective shield and the wiring fastened within 3 inches on each side of the edge.
- (2) Grommets must be used where wires pass through holes in sheet metal, castings, and / or frame rails. Do not bend wires in a radius smaller than 10 times the wire diameter.
- (3) Routing wires into areas exposed to wheel wash should be avoided. If this cannot be avoided protective shields are required to protect the wires from stones, ice, salt and water damage. Provide a drip loop to prevent moisture from being conducted into switches, relays, circuit breakers, and fuses.
- (4) Wires should be supported every 18 inches with plastic zip ties or rubber-lined clips.
- (5) Wires must be routed to clear moving parts by at least 3 inches unless positively fastened or protected by a conduit. If wiring must be routed between two members where relative motion can occur, the wiring should be secured to each member, with enough wire slack to allow flexing without damage to the wire.
- (6) Maintain at least a 6 inch clearance from exhaust system components. If this is not possible, high temperature insulation and heat shields are required. Existing OEM heat shields, insulation, and wire shielding must be maintained.
- (7) Do not route or attach electrical wires to fuel lines. Route electrical wires at least 1-1/2 inches away from the engine.

BATTERY, WIRE, TERMINALS, AND CONNECTORS

- (1) Wire attachments at the battery must be protected from tension loads so there is no undue strain on the battery terminals. Wires should be routed down rather than horizontally from the terminals with no sharp bends adjacent to the connections.
- (2) Battery power for your Tommy Gate should come directly from the battery or approved connection point through the supplied circuit breaker or fuse. The circuit breaker or fuse should be installed as close to the battery as possible.
- (3) Avoid splicing power cables. If splicing is necessary, the most durable splice joint will be bare metal barrel crimped, flow-soldered and covered with adhesive lined heat shrink tubing. Strip the wire ends making sure that individual conductor strands are not damaged. Use only rosin core solder, proper crimping tools, and wire with a gauge at least equivalent to the circuit being lengthened. Do not use electrical tape.
- (4) Battery cable terminals will be bare metal barrel crimped or flow-soldered and covered with adhesive lined heat shrink tubing.
- (5) Use wire connectors with locking features such as positive locking, inertia locking, bolt together, and soft mold-over with locking external retainers.

GENERAL

- (1) All frame contact areas must be wire brushed to bare metal, free of paint, dirt, and grease. Frame connections must be made using hardened flat washers under the bolt head and lock nuts. Corrosion preventive grease or compound is to be applied to the terminal area of the frame connection.
- (2) Frame cross members are not recommended as part of the ground return.
- (3) All circuit breakers and fuses should be located in one easily serviceable location with a means provided for identification of circuit function and current rating. If possible, avoid putting circuit breakers or fuses in the vehicle cab.
- (4) Before welding to the chassis disconnect the battery. Also disconnect the power train, engine, valve, and transmission control modules.
- (5) Do not alter vehicle ignition, starting, and / or charging systems. Do not reroute engine compartment wiring.
- (6) Full copper circuitry and standardized polarity grounds are recommended.
- (7) Never increase the rating of a factory installed fuse or circuit breaker.
- (8) Disconnect the battery negative (ground) wire prior to any vehicle modification.

Following the above guidelines will provide you with years of trouble free service. Failing to incorporate the above guidelines may result in a voided warranty. Non-compliance with the guidelines above may result in a failure of electrical components, shutdown of engines, loss of backup brake systems, and the possibility of fire.



SVE BULLETIN

SPECIAL VEHICLE ENGINEERING – BODY BUILDERS ADVISORY SERVICE

E-Mail via Website: www.fleet.ford.com/truckbbas (click "Contact Us")

Toll-free: (877) 840-4338

QVM Bulletin: Q-226R2

Date: 20 October, 2014

Revised: 13 March, 2017

Revision	Update	Revision Date
Q-226R2	Added recommendation for vehicles requiring greater than 30 Amps	13 March, 2017

Accessing Battery Power on Transit

Models Affected: 2015 Transit – All models

Description: For modifications and equipment installations requiring B+ current loads greater than 30 Amps, the guidelines provided below should be followed.

NOTE: If a converter intends to add systems or accessories that will add significant electrical load (particularly at key off), then vehicles with twin High Performance Deep Cycle AGM batteries should be specified. The twin option is the standard heavy duty system for loads greater than 5mA continuous at key off or 30A at engine run. It is also recommended to upgrade to the heavy duty alternator option if the extra loads are continuously active at engine run and exceed 30A above standard Ford systems.

For Battery Power Less than 60 Amps

- Connect to the 1 x 60A Customer Connection Point (CCP) in the Pre Fuse Box (PFB)
- 1 x 60A MIDI fuse is present on all Transit vehicles (within the PFB in the driver seat pedestal).
- See the Transit Body and Equipment Mounting Manual (BEMM) for information regarding the use of the CCP's.

For B+ Battery Power Greater than 60 Amps

Vehicles with factory installed 3 X 60A Customer Connection Points (available with option 67C-Upfitter switches)

- Connect to the 3 x 60A Customer Connection Points on the driver seat pedestal.
- The CCP's are capable of providing up to a total of 180A.
- Refer to the BEMM for information regarding the use of CCP's

Vehicles without factory installed 3 X 60A Customer Connection Points.

Upfitters may order a Customer Connection Point kit through Ford dealers. The kit part number is:
BK2Z-14S411-A

This kit provides hardware for two additional 60 Amp CCP terminals, allowing the modifier to upgrade from the standard single 60 Amp CCP to three 60 Amp CCP's, for a total of 180 Amps.

For Battery Power Greater than 180A

Vehicles equipped with dual AGM batteries will have a single empty B+ battery post on the rear or second AGM battery (see figure 1). Upfitters wishing to connect to this terminal must adhere to the following guidelines:

- Use only a W520101-S437 nut to secure the aftermarket eyelet (M6 - Electrolytic zinc plate, trivalent chromate, and clear sealer, with integral torque control lubricant). **No other nut or finish may be used.**
- The additional cable eyelet must have a complete flush contact to the terminal and be fully secured.
- The nut must be torqued to **8Nm [+/- 1.2Nm]**.
- The additional battery connection must be protected with an appropriately sized fuse.

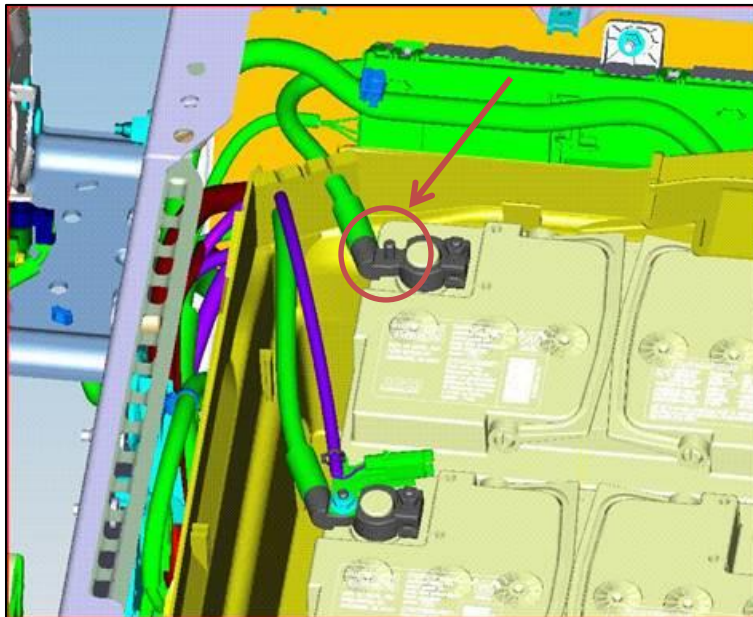

Fig. 1: Location of empty B+ battery post

Note: Single Battery variants

The B+ post on the single battery terminal can only accommodate a single terminal connection. The post is fully occupied by the alternator sense circuit, and cannot support an additional aftermarket terminal connection. **Any additional terminal connection to the single post may cause the charging system to malfunction or fail.** Upfitters connecting to the single battery post must provide an additional stud for their connection. All connection recommendations for the dual battery configuration shown above must be followed, and the additional connection and battery terminal must be protected with an appropriate battery terminal cover.

If you have any questions, please contact the Ford Truck Body Builders Advisory Service as shown in the header of this bulletin.