

INSTALLATION INSTRUCTIONS

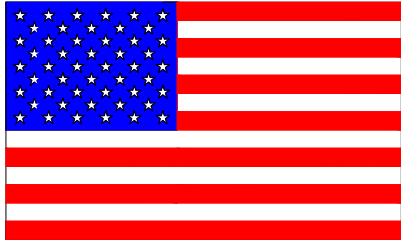

Woodbine, Iowa



Made in America

1600 & 2000 Aluminum Roller Railgate Series

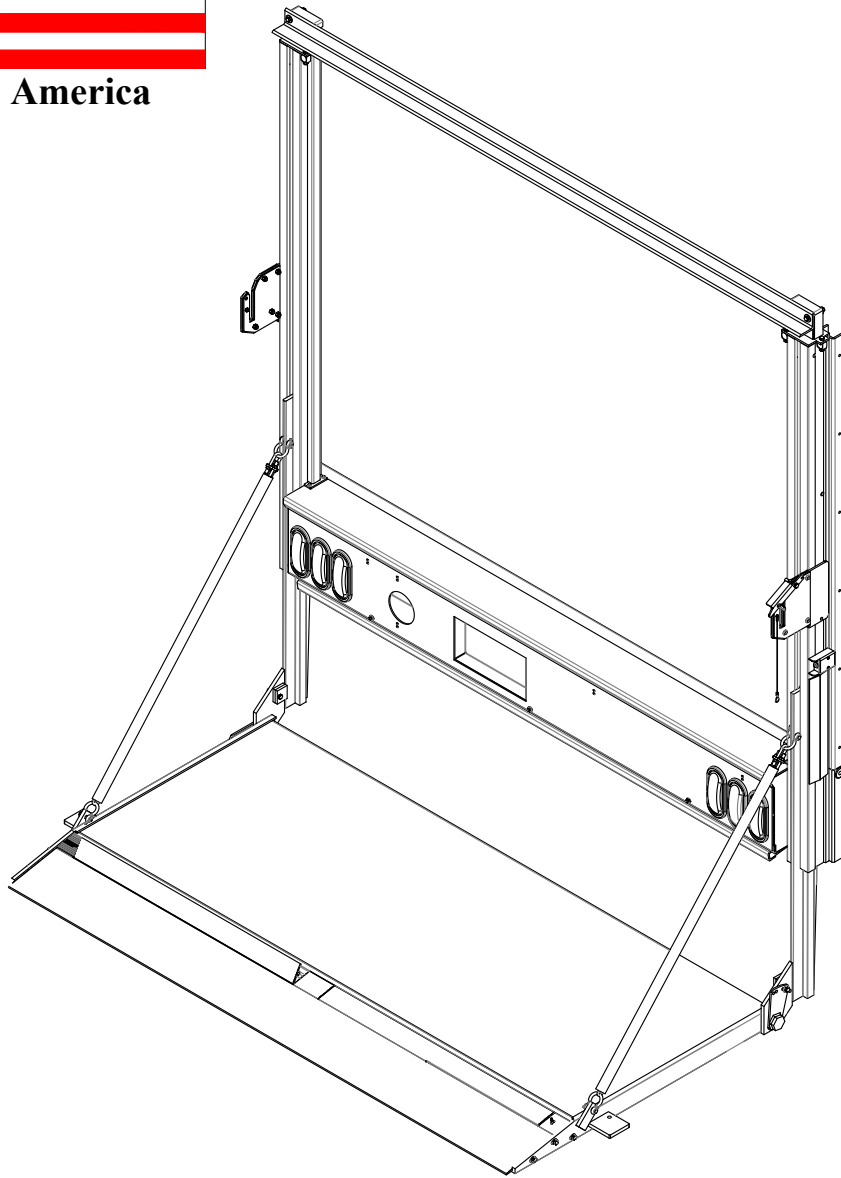

CAUTION

Before installing or using this liftgate, please observe the Vehicle Loading Limitations. These loading limitations are outlined in the Vehicle Owner's Manual and the Safety Compliance Certification Label located on the drivers door pillar.



CAUTION

Aluminum Frame Railgate Series Mounting Instructions

Step 1. The truck or trailer onto which the railgate is to be mounted must be built with certain structural components to ensure that it is capable of supporting both the railgate weight and the maximum load to be lifted by the railgate.

NOTE: A maximum length of 6 inches of unsupported upright is acceptable. Refer to Step 12 for specific instructions on support bracket recommendations.

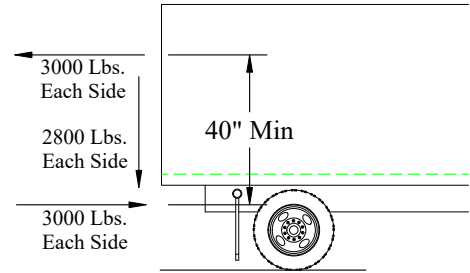

Step 2. Use the mounting aid to insure that the liftgate is installed even with the bed height.

Step 3. Remove the mainframe box cover by removing the three 5/16" hex nuts. Some loose parts may be packaged inside the mainframe box. Remove and retain these items along with the box cover and fasteners.

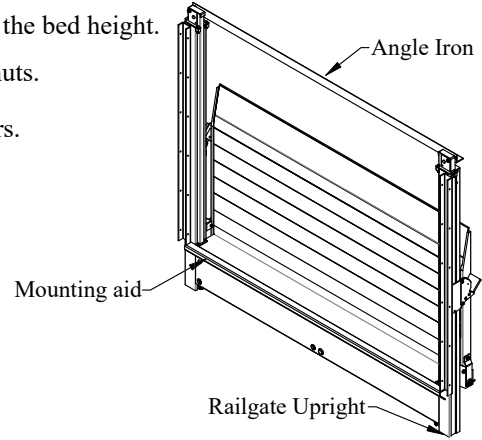

Mounting liftgate to the truck

Step 4. Raise the railgate using one of two methods. First method is with a chain hoist and strap, second method is to use a fork truck. With either method make sure to pick the railgate up using the angle iron attached to the top of the uprights.

Position the railgate onto the truck or trailer using the mounting aid as a guide.

NOTE: Make sure that the control wire is clear (to avoid pinching or cutting) before installing the gate.

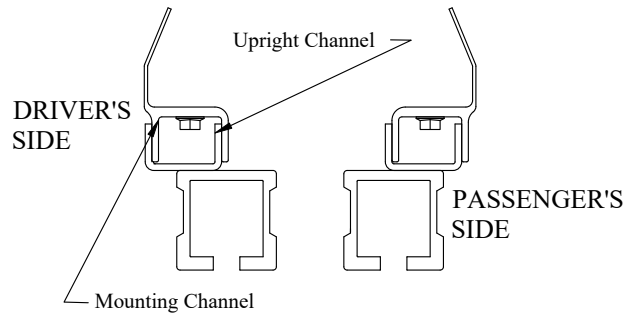
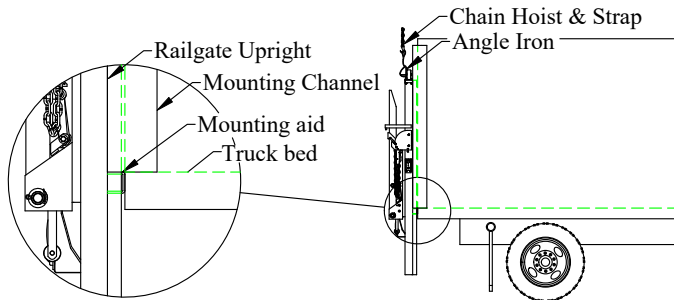

Step 5. Referring to the figures above, position the lift gate so the Driver's side Upright Channel is on the outside of the Driver's side Mounting Channel. At the same time position the Passenger's side Upright Channel to the inside of the Passenger's side Mounting Channel.

Step 6. Drill twelve Ø5/16" holes (six per side) completely through the Mounting Channel using the existing holes in the Upright Channels as a template. Install a 5/16" X 4" Cap Screw, Grade 5 (not included) in each of these twelve holes drilled. Install nut on each 5/16" X 4" HHCS and tighten. On each 5/16" X 4" HHCS lock the first nut by jamming a second nut into the first nut.

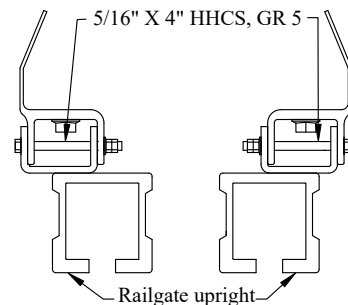

Step 7. Install the circuit breaker on the firewall, fender of the truck, or other location out of the way of moving parts. Be sure there is easy access for installation of the power cables and so the circuit breaker can be reset.

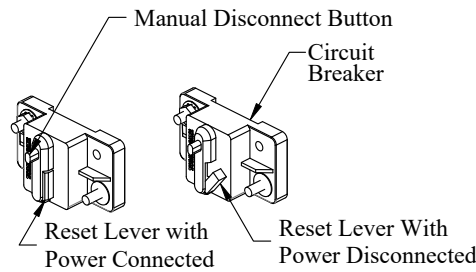

Step 8. Locate the three strain reliefs in the liftgate mainframe. Loosen the two screws on the strain relief. Disconnect the positive lead from the terminal on the raise solenoid and the negative cable from the pump and motor common ground. Pull the shipping electrical cable out of the strain relief. Discard the cable.

The liftgate electrical cables are coiled in a separate box that is shipped with the liftgate. Carefully pull the cable ends with the copper lugs installed through the bottom of the strain relief and connect the positive cable to the terminal on the raise solenoid. **Do not overtighten the raise solenoid nuts. Tighten to 35in-lb max.** Connect the negative lead to the common ground on the pump and motor unit. Tighten bolt to 18ft-lb max. Leave approximately two inches of slack inside the liftgate mainframe. Tighten the two screws on the strain relief.

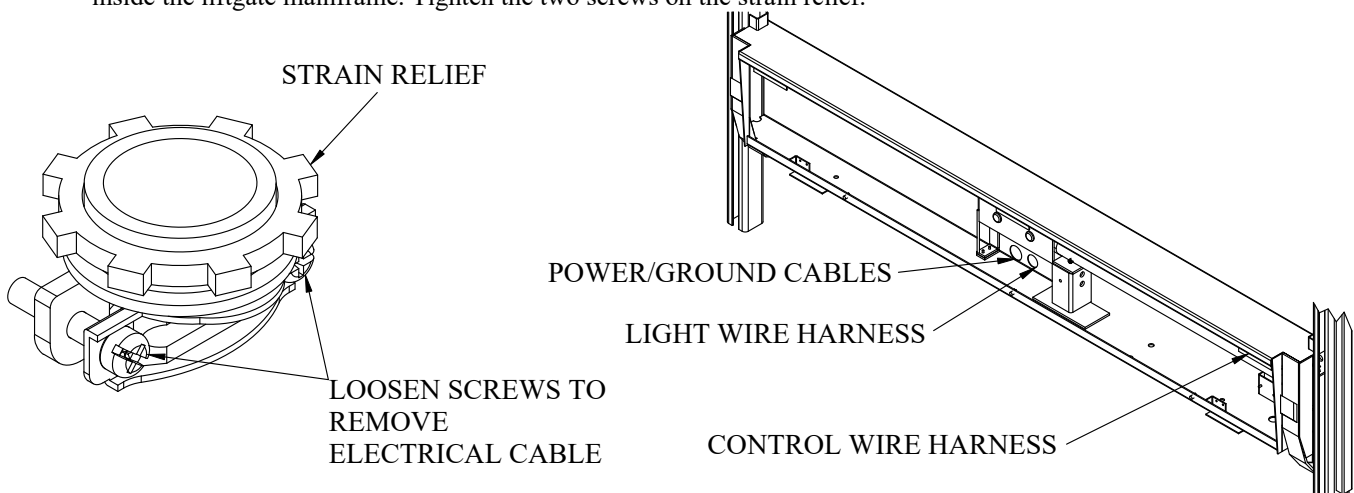

Step 9. Carefully route the cables according to the Tommy Gate Electrical Guidelines along the frame to the battery. Pull the excess cables beyond the battery and separate the positive (+) and negative (-) leads. Cut the positive (+) lead to the length required to reach the auxiliary (AUX) terminal of the circuit breaker. The remaining positive (+) lead needs to be cut at the length required to span the distance from the circuit breaker battery (BAT) terminal to the positive battery terminal.

Cut the negative (-) lead to the length required to reach the negative battery terminal. Install copper lugs on all required ends and attach to the circuit breaker and battery as outlined in the Tommy Gate Electrical Guidelines and wiring diagram.

IMPORTANT: The pump and motor unit for this lift can require significant electrical power at 12VDC. Be sure you connect the negative(-) cable to the negative(-) terminal of the vehicle battery.

!!! PLEASE READ AND FOLLOW ALL DIRECTIONS BEFORE PROCEEDING !!! **IMPORTANT** **NOTE !!! IF GATES ARE NOT WIRED IN ACCORDANCE WITH THIS DIAGRAM YOUR WARRANTY WILL BE VOID.**

WELDING NOTE !!! DISCONNECT ALL BATTERY CABLES. ALWAYS DISCONNECT THE GROUND CABLE FIRST. ATTACH THE WELDING GROUND TO THE TRUCK RATHER THAN THE LIFTGATE. **IMPORTANT**

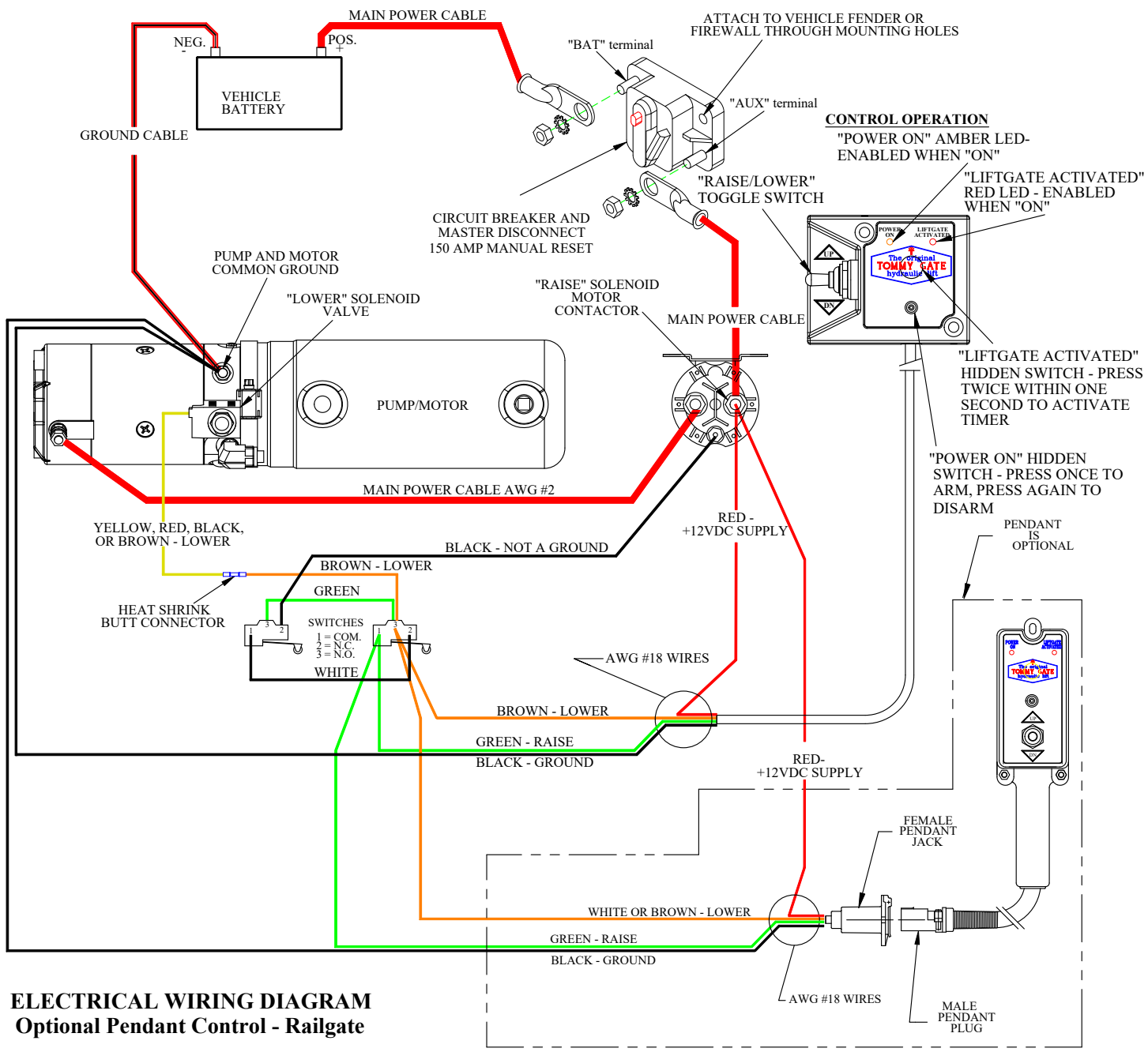

ELECTRICAL WIRING DIAGRAM
Optional Pendant Control - Railgate
PENDANT JACK WIRING DIAGRAM

FEMALE CONNECTOR BACK VIEW
 WIRE INSERTION SIDE

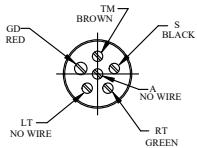

COLE HERSEE SOCKET END	
POSITION	WIRE COLOR
S	BLACK
RT	GREEN
LT	NO WIRE
TM	BROWN
A	NO WIRE
GD	RED

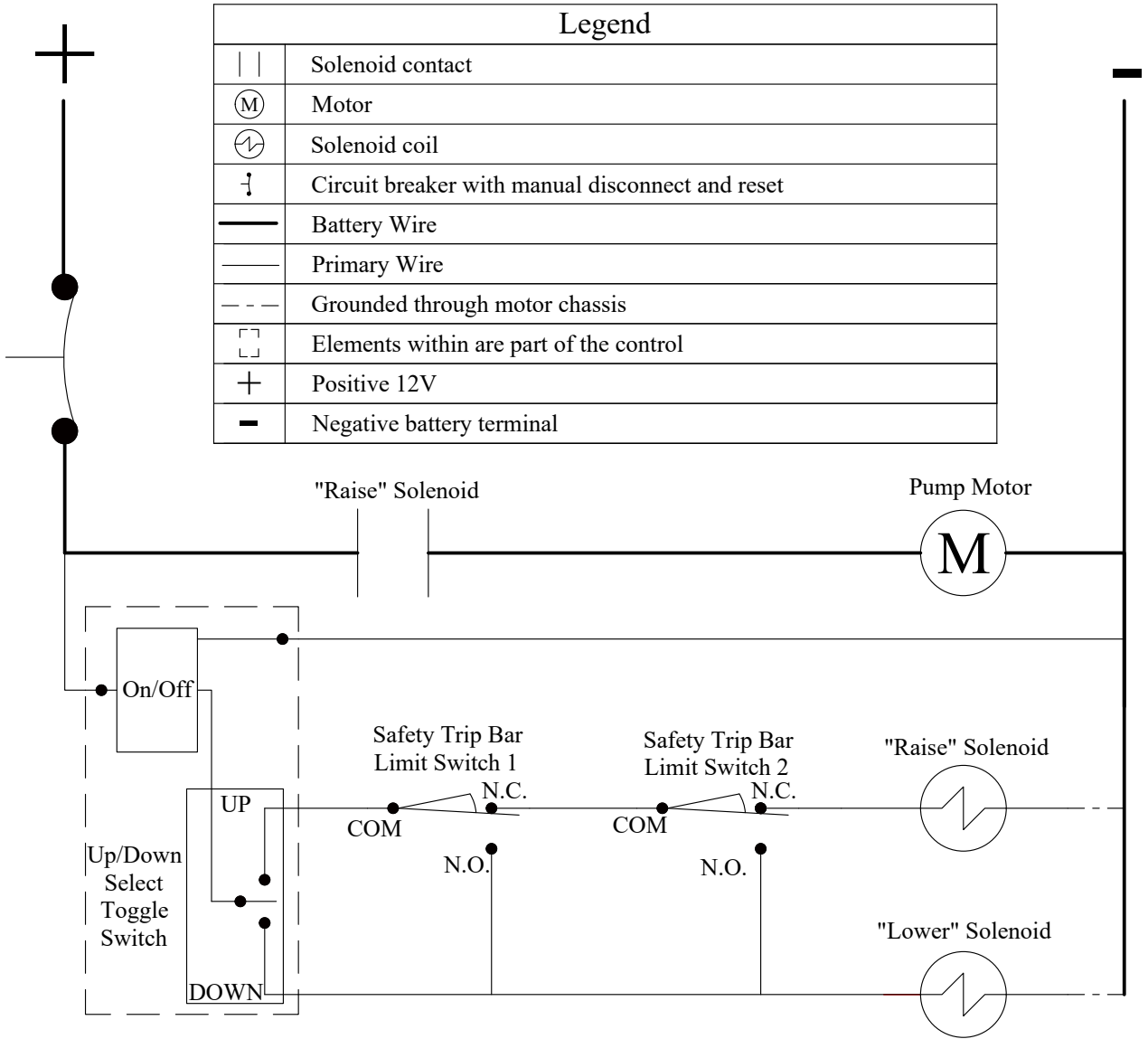

WIRE ROUTING

- (1) When routing wires, avoid heat (above 180°F), abrasion, vibration, metal edges, screws, and trim fasteners. If such routings are not possible, protective devices must be used. If wires must cross a metal edge, the edge should be covered with a protective shield and the wiring fastened within 3 inches on each side of the edge.
- (2) Grommets must be used where wires pass through holes in sheet metal, castings, and / or frame rails. Do not bend wires in a radius smaller than 10 times the wire diameter.
- (3) Routing wires into areas exposed to wheel wash should be avoided. If this cannot be avoided protective shields are required to protect the wires from stones, ice, salt and water damage. Provide a drip loop to prevent moisture from being conducted into switches, relays, circuit breakers, and fuses.
- (4) Wires should be supported every 18 inches with plastic zip ties or rubber-lined clips.
- (5) Wires must be routed to clear moving parts by at least 3 inches unless positively fastened or protected by a conduit. If wiring must be routed between two members where relative motion can occur, the wiring should be secured to each member, with enough wire slack to allow flexing without damage to the wire.
- (6) Maintain at least a 6 inch clearance from exhaust system components. If this is not possible, high temperature insulation and heat shields are required. Existing OEM heat shields, insulation, and wire shielding must be maintained.
- (7) Do not route or attach electrical wires to fuel lines. Route electrical wires at least 1-1/2 inches away from the engine.

BATTERY, WIRE, TERMINALS, AND CONNECTORS

- (1) Wire attachments at the battery must be protected from tension loads so there is no undue strain on the battery terminals. Wires should be routed down rather than horizontally from the terminals with no sharp bends adjacent to the connections.
- (2) Battery power for your Tommy Gate should come directly from the battery through the supplied circuit breaker or fuse. The circuit breaker or fuse should be installed as close to the battery as possible.
- (3) Do not splice battery cables. If splicing is necessary, the most durable splice joint will be bare metal barrel crimped, flow-soldered and covered with adhesive lined heat shrink tubing. Strip the wire ends making sure that individual conductor strands are not damaged. Use only rosin core solder, proper crimping tools, and wire with a gauge at least equivalent to the circuit being lengthened. Do not use electrical tape.
- (4) Battery cable terminals will be bare metal barrel crimped or flow-soldered and covered with adhesive lined heat shrink tubing.
- (5) Use wire connectors with locking features such as positive locking, inertia locking, bolt together, and soft mold-over with locking external retainers.

GENERAL

- (1) All frame contact areas must be wire brushed to bare metal, free of paint, dirt, and grease. Frame connections must be made using hardened flat washers under the bolt head and lock nuts. Corrosion preventive grease or compound is to be applied to the terminal area of the frame connection.
- (2) Frame cross members are not recommended as part of the ground return.
- (3) All circuit breakers and fuses should be located in one easily serviceable location with a means provided for identification of circuit function and current rating. Do not put circuit breakers or fuses in the vehicle cab.
- (4) Before welding to the chassis disconnect the battery. Also disconnect the power train, engine, valve, and transmission control modules.
- (5) Do not alter vehicle ignition, starting, and / or charging systems. Do not reroute engine compartment wiring.
- (6) Full copper circuitry and standardized polarity grounds are recommended.
- (7) Never increase the rating of a factory installed fuse or circuit breaker.
- (8) Disconnect the battery negative (ground) wire prior to any vehicle modification.

Following the above guidelines will provide you with years of trouble free service. Failing to incorporate the above guidelines will result in a voided warranty. Non-compliance with the guidelines above may result in a failure of electrical components, shutdown of engines, loss of backup brake systems, and the possibility of fire.

Step 10. Remove the solid plastic plug from the reservoir and replace it with the vent plug provided. The hydraulic system has already been filled with the proper amount of fluid. Do not add any at this time.

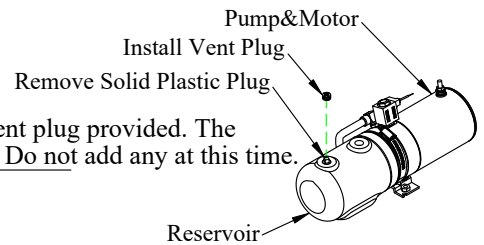

Step 11. Check the clearance between the ground and the bottom of the upright. Ground clearance under the upright is influenced by truck suspension, box of platform overhang, terrain to be traveled over and maximum load to be hauled. Too little ground clearance may result in the rail gate upright hitting the ground when traveling. This will result in a failure of the lift gate.

Too much clearance between the bottom of the upright and the ground can also be problematic. This rail gate is designed to operate with a ground clearance of no more than 22-1/2" when measured on level ground. If your installation has more than 22-1/2" of ground clearance the gate will travel too far out of the uprights when lowered down on the ground. This situation will damage the rail gate.

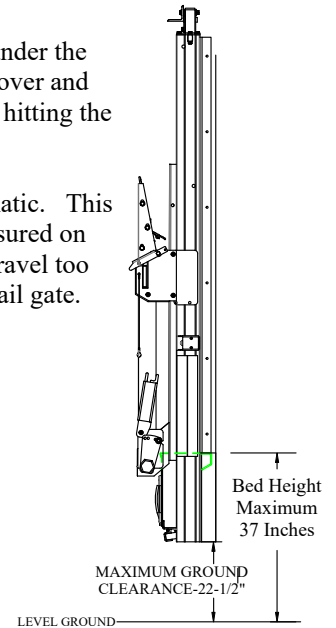

Step 12. If more than 6 inches of the upright extends below the bottom support, a gusset or brace must be used as illustrated.

Step 13. Remove the lifting/installation/shipping angle iron by removing the bolts.

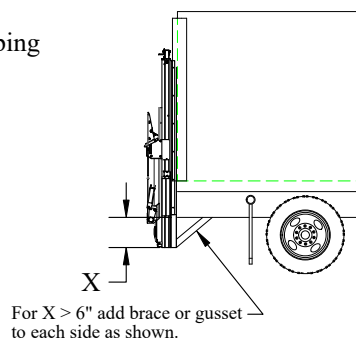

Step 14. Adjust the platform chains on the gate to equalize the weight distribution between the two chains.

- a) Park the vehicle on level ground.
- b) Lower the platform until it is a few inches off the ground.
- c) Grab the middle of each of the chains to check the tension. (DO NOT stand or put anything on the platform when performing this check.)
- d) If the tension on both chains appears to be equal, no adjustment is required.
- e) If one chain has less tension than the other chain perform one of the following:

NOTE: NO PART OF THE CHAIN WILL NEED TO BE DISCONNECTED TO ADJUST THE CHAIN TENSION.

1. Tighten the U-bolt lock nuts at the chain adjuster on the loose chain or
 2. Loosen the U-bolt lock nuts at the chain adjuster on the tight chain.
- f) Recheck the tension of the platform chains.
 - g) If the tension on both chains appears to be equal, proceed to the next step.
 - h) If further adjustment is needed, repeat the above process (STEP 14e 1-2).

!!WARNING!! VERIFY THAT THREADS OF THE U-BOLT ARE PROTRUDING THROUGH EACH NUT TO AVOID PULLING OF THREADS RESULTING IN FAILURE OF CHAIN TENSION ADJUSTOR.

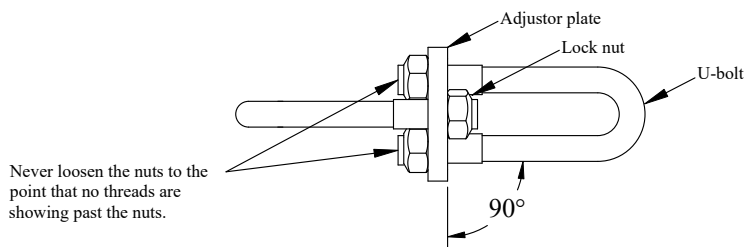
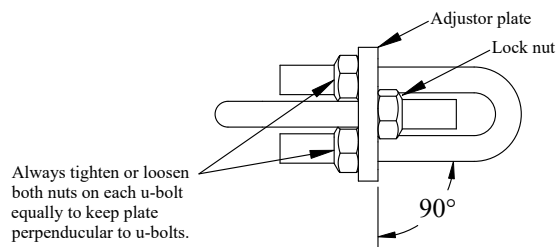

!!WARNING!! ALWAYS ADJUST THE PAIR OF LOCK NUTS ON EACH U-BOLT EQUALLY TO KEEP THE PLATE PERPENDICULAR TO THE U-BOLTS DISTRIBUTING EQUAL TENSION. FAILURE TO DO SO MAY RESULT IN PREMATURE FAILURE OF CHAIN ADJUSTOR.

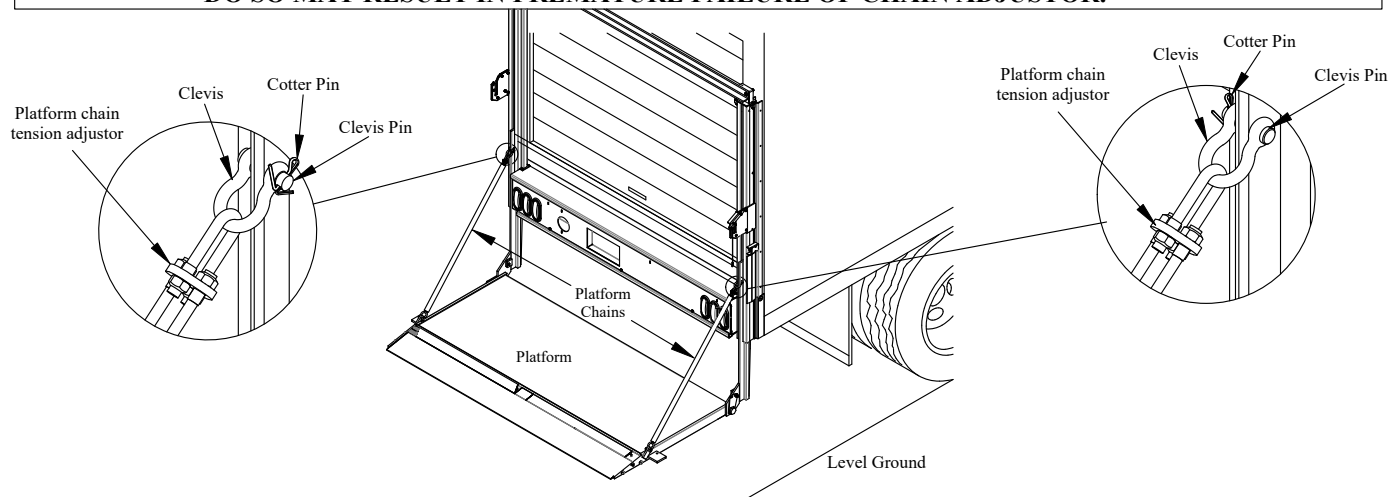

Step 15. Adjust the platform taper.

- To adjust the platform taper lower the platform to the ground and use the same process that was used to adjust the chain tension (STEP 14e 1-2).
- If you loosen the lock nuts, the taper will lower (Adjust each chain equally).
- If you tighten the lock nuts, the taper will rise (Adjust each chain equally).

!!WARNING!! ALWAYS KEEP EQUAL TENSION ON BOTH CHAINS TO AVOID OVERLOADING A SINGLE CHAIN AS THIS WILL CAUSE CHAIN FAILURE.

Step 16. Test the operation of the liftgate.

- Load the platform with the rated capacity and measure the time necessary to raise the platform. The load should lift through 54 inches of travel in 23-29 seconds or 2-2.5 in/sec.
- Move the platform to its highest position.
- Examine the platform for any downward creep.
- With the platform still loaded, time the lowering operation. The load should descend at approximately 10 in/sec.
- Remove the load from the platform and examine the railgate and truck for any problems.

Step 17. Install the license plate light in the box cover using the provided screws and lock nuts.

Step 18. Push the license plate nuts into the square holes in the box cover, then use the 1/4"x1/2" stainless steel screws to mount the license plate.

Step 19 Install the wiring harness for the lights.
 a). To avoid the risk of an electrical short, disconnect the power cable from the positive side of the battery or manually trip the circuit breaker.
 b). Connect the plugs on the harness to the lights on the box cover observing the relationship with the color of wire in the plug to the corresponding light.

NOTE: Make sure that the plug with the yellow "LT/HAZ/TAIL" label is on the driver's side and the plug with the green "RT/HAZ/TAIL" label is on the passenger's side.

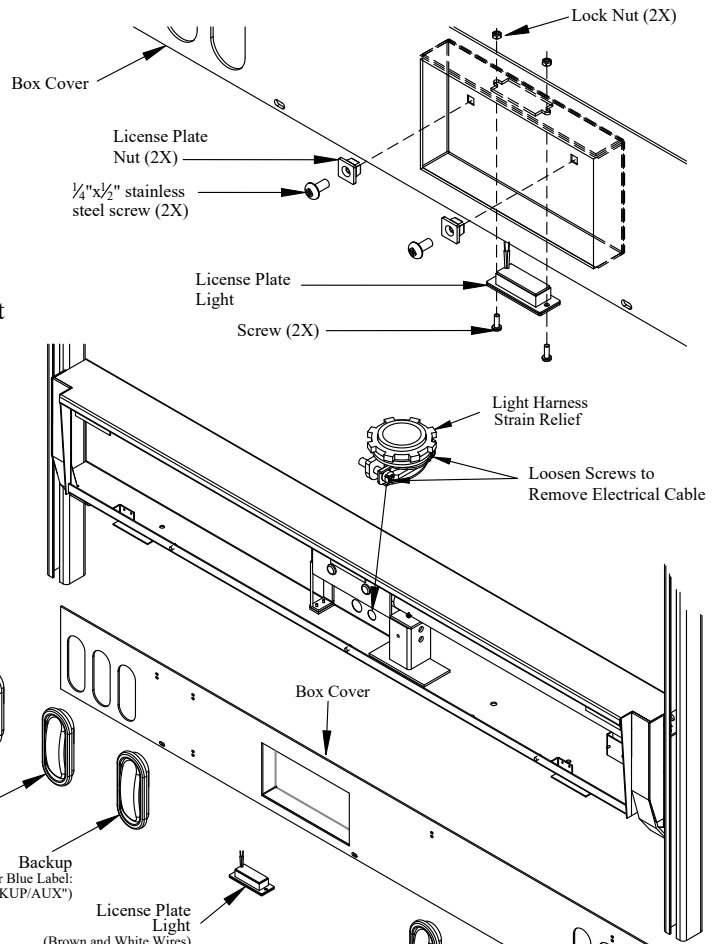

c) The brown and white wires that connect to the license plate light must be connected using heat shrink butt connectors.

!!!CAUTION: KEEP ALL WIRES CLEAR OF PINCH POINTS AND MOVING PARTS!!!

d) Using the obround holes punched in the box cover and plastic button head wire ties provided, attach the harness to the back of the box cover as shown. If needed, coil the harness in the position shown to keep the harness tight.

NOTE: If the harness is not routed in accordance with the pictures, the harness will be severed by moving parts.

- e) Pull the harness end to be attached to the vehicle down through the light harness strain relief in the front of the liftgate mainframe.
- f) Connect the harness to the vehicle's wiring.
- g) Install the license plate light.
- h) Check the lights for proper operation.
- i) Reinstall the box cover.
- j) Verify proper operation of lights.

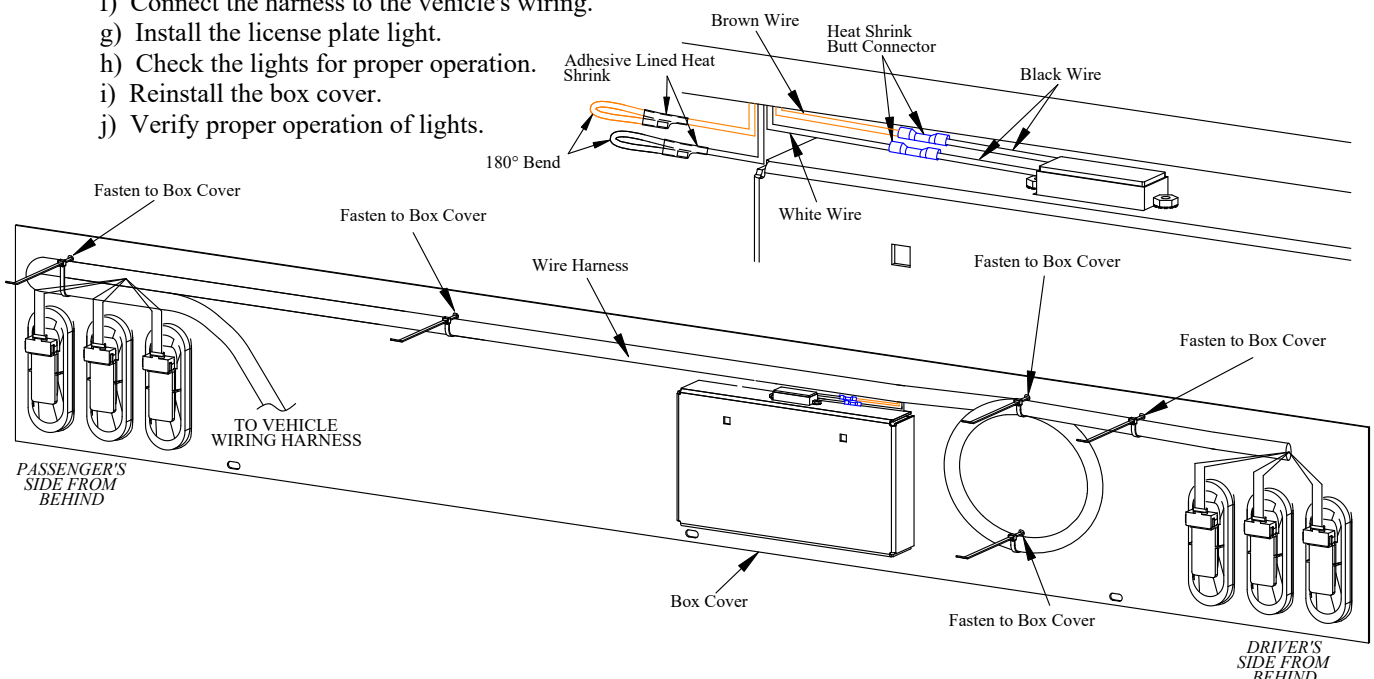
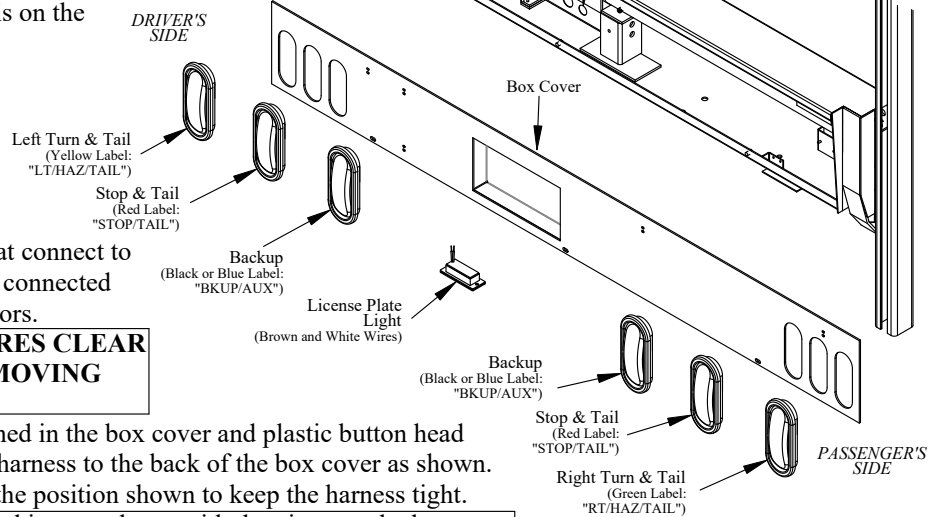

Railgate Wiring Diagram

ELECTRICAL GUIDELINES:

- (1) THE INSTALLER IS RESPONSIBLE FOR USING PROPER TECHNIQUES WHEN INTERFACING WITH VEHICLE ELECTRICAL SYSTEMS.
- (2) FAILURE TO COMPLY WITH THE OEM GUIDELINES COULD RESULT IN UNSAFE VEHICLE OPERATION, FAILURE OF OEM WIRING, OR VEHICLE FIRE.
- (3) NEVER REPLACE OEM FUSES AND/OR CIRCUIT BREAKERS WITH FUSES OR CIRCUIT BREAKERS WITH A HIGHER RATING.
- (4) THE TOTAL CIRCUIT CURRENT DRAW SHOULD NOT EXCEED 80% OF THE OEM CIRCUIT FUSE OR CIRCUIT BREAKER.
- (5) USE BODY BUILDER JUNCTION BLOCKS, CUSTOMER ACCESS CIRCUITS & CONNECTORS RATHER THAN EXTENDING OEM CIRCUITS.
- (6) INCORPORATE RELAYS INSTEAD OF SPLICING INTO THE OEM ELECTRICAL SYSTEM.
- (7) USE APPROPRIATE GAUGE WIRE FOR EXTENDING CIRCUITS. THE WIRE GAUGE SHOULD BE CAPABLE OF SUPPORTING THE MAXIMUM LOAD TO WHICH THE ADDED CIRCUIT WILL BE EXPOSED.
- (8) OEM ELECTRICAL WIRE COLOR CODING SHOULD BE MAINTAINED WHEN EXTENDING CIRCUITS.
- (9) WHEN ADDING CIRCUITS, ALWAYS INCORPORATE FUSE OR CIRCUIT BREAKER PROTECTION.

NOTE: ⊗ SYMBOL INDICATES USAGE OF HEAT SHRINK BUTT CONNECTOR
 X INDICATES WIRE END IS SEALED AWAY AND NOT USED.

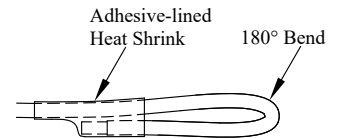

COMBINED STOP/TURN FUNCTION

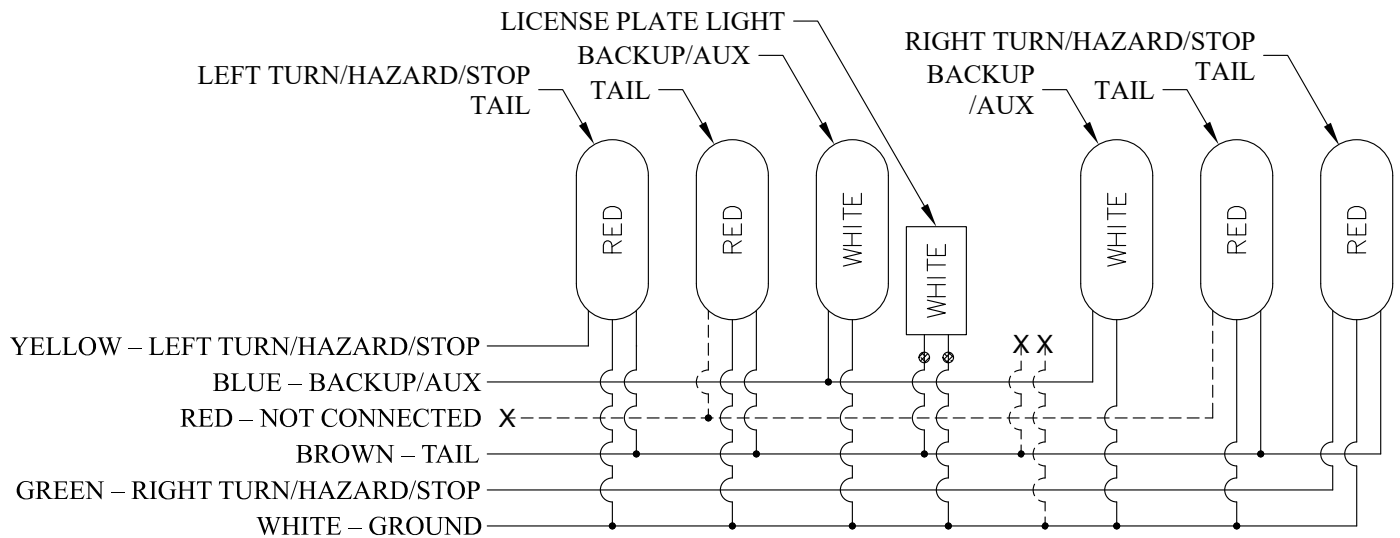

SEPARATED STOP/TURN FUNCTION

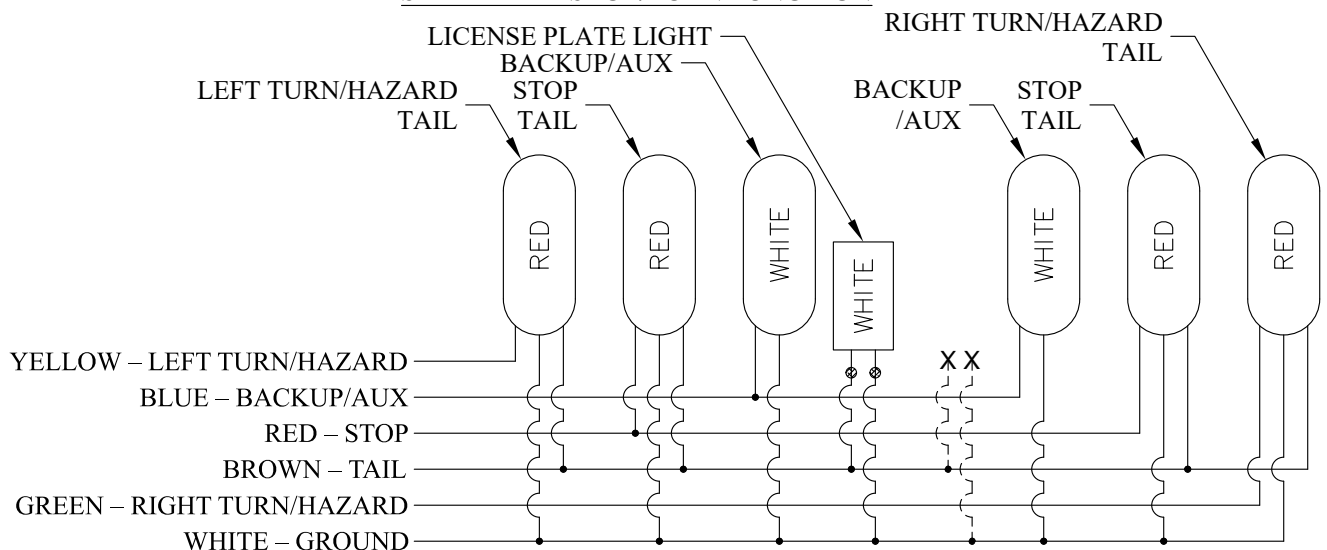

Step 20. **Make sure all decals are clean and legible.** Additional decals are available from the factory, if needed.

Step 21. Place Owners/Operators manual in the truck.

Step 22. Always install the latch padlock, deactivate the control, and disable lift gate using the in cab cut off switch (if equipped) when not in use.

