

Replacement Platform Instructions 2500/3000 Rail Bifold Models

These instructions will assist you in replacing the BiFold Platform.

Removing the old Platform

1. **Remove** the latch padlock and **Unhook** the safety chain (Figure 1).
2. **Unlatch** the latch lever from the latch peg (Figure 1).

CAUTION: Stand off to the side clear of the platform while operating the liftgate.

3. **Lower** the liftgate until the platform is fully opened and the self close arm is disengaged (Figure 2).
4. **Position** the liftgate at a comfortable height to be able to perform steps 6-7.
5. **Disconnect** the power cable from the positive side of the battery or manually **Trip** the circuit breaker.
6. **Prepare** the platform to weld on each side at the locations shown (Figure 2).

WARNING! If the supports are not strong enough or if they are not welded securely the platform could fold unexpectedly.

7. **Weld** four 1/4" x 1.50" long welds connecting a support brace to the underside of the platform on each side to prevent the platform from folding during the removal process (Figure 2).

Note: Tommy Gate recommends using two steel angle irons with 2.50" legs x 5/16" thick x 49.50" long for the supports.

8. **Connect** the power cable to the positive side of the battery or manually **Engage** the circuit breaker.
9. **Lower** the liftgate until the platform is resting on the ground with the retention ramp end slightly higher than the hinge end to allow the platform chains to hang loose.
10. **Disconnect** the power cable from the positive side of the battery or manually **Trip** the circuit breaker.
11. **Detach** the top platform chain from the slider on each side by **Removing** the cotter pin and clevis pin (Figure 2).
12. **Note** the shim number and locations relative to the slider. This will be how the replacement parts are installed (Figure 2).
13. **Remove** the cotter pin from one end of the platform hinge tube and **Remove** the hinge tube (Figure 2).
14. **Remove** the platform.

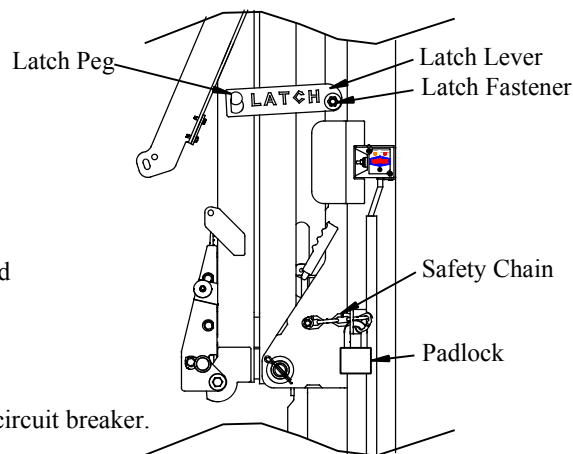

Figure 1

Platform chains removed for clarity.

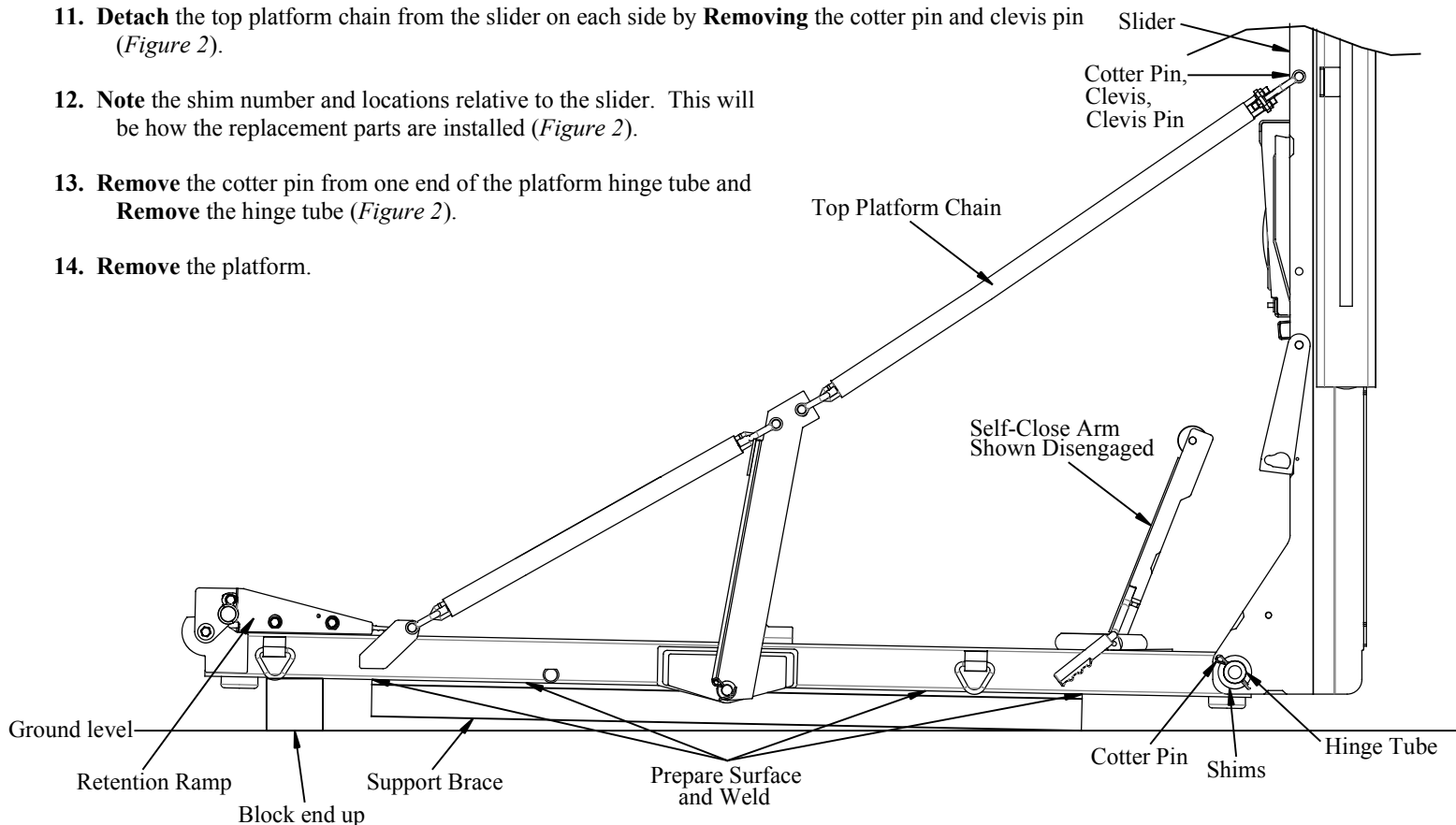

Figure 2

Replacement Platform Instructions 2500/3000 Rail Bifold Models

Installing the new Platform

15. **Position** the new platform on the ground between the sliders so that hinge holes in the platform are in line with the holes in the sliders.

Note: The Retention Ramp end should be slightly higher than the hinge end of the platform.

16. **Insert** the hinge tube through the slider, shims, and platform (*Figure 3*).

Note: The shims need to be in the position that they were noted in step 12.

17. **Install** the cotter pins in each end of the hinge tube (*Figure 3*).

18. **Attach** the platform chains to the sliders using the supplied clevises and clevis pins (*Figure 3*).

19. **Install** the cotter pin in the clevis pin on each side of the platform (*Figure 3*).

20. **Connect** the power cable to the positive side of the battery or manually **Engage** the circuit breaker.

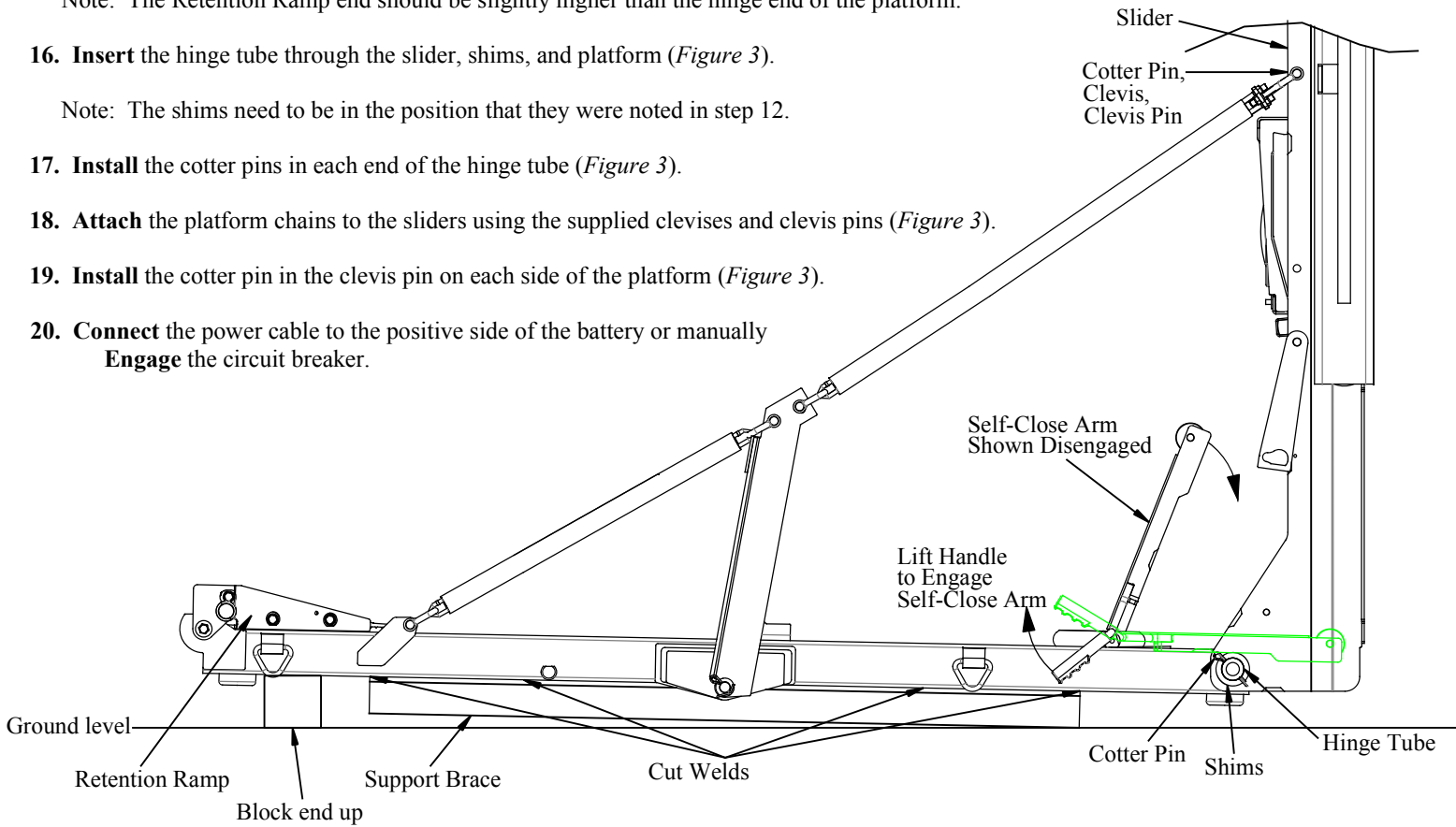

Figure 3

21. Keeping the platform horizontal, **Raise** the platform to a comfortable height to perform steps 23-25.

22. **Disconnect** the power cable from the positive side of the battery or manually **Trip** the circuit breaker.

23. Being careful not to cut into the platform, **Cut** the welds attaching the support braces to the platform (*Figure 2*).

24. **Prepare** the bare steel and **Apply** touch up paint to the platform.

25. **Verify** that the platform is level with the ground. If it is not, refer to page 3 for chain adjustment.

26. **Connect** the power cable to the positive side of the battery or manually **Engage** the circuit breaker.

27. **Engage** the self-close arm (*Figure 3*).

28. **Raise** the liftgate until the platform is folded and the latch rollers are locked in the latch plates (*Figure 4*).

29. **Latch** the latch lever over the latch peg (*Figure 1*).

30. **Hook** the safety chain and **Attach** the padlock (*Figure 1*).

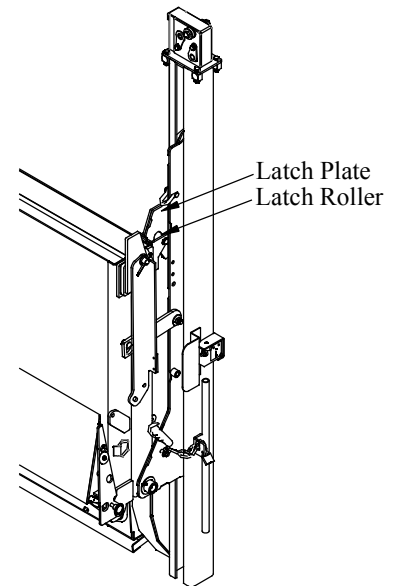

Figure 4

Platform chains removed for clarity.

CAUTION: Stand off to the side clear of the platform while operating the liftgate.

Replacement Platform Instructions 2500/3000 Rail Bifold Models

Adjusting the Platform Chains

This section will assist you in adjusting the platform chains.

31. **Park** the vehicle on level ground.
32. **Lower** the platform until it is a few inches off the ground.
33. **Grab** the middle of each of the upper chains to check the tension. (DO NOT stand or put anything on the platform when performing this check.)
34. If the tension on both chains appears to be equal, no adjustment is required.
35. If one chain has less tension than the other chain **Perform** one of the following:

NOTE: NO PART OF THE CHAIN WILL NEED TO BE DISCONNECTED TO ADJUST THE CHAIN TENSION.

- a) **Tighten** the u-bolt lock nuts at the chain adjuster on the loose chain or
- b) **Loosen** the u-bolt lock nuts at the chain adjuster on the tight chain.

36. **Recheck** the tension of the upper platform chains.
37. If the tension on both upper chains appears to be equal, **proceed** to the next step.
38. **Adjust** the platform taper.
 - a) If you **loosen** the lock nuts, the taper will lower (Adjust each chain equally).
 - b) If you **tighten** the lock nuts, the taper will rise (Adjust each chain equally).

!!WARNING!! Always keep equal chain tension on both sides to avoid overloading a single chain as this may cause chain failure.

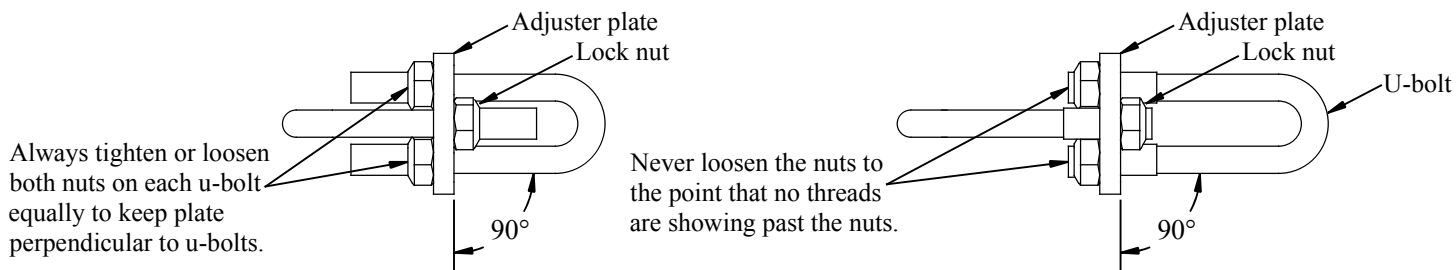

WARNING! Always adjust the pair of lock nuts on each u-bolt equally to keep the plat perpendicular to the u-bolts distributing equal tension. Failure to do so may result in premature failure of the chain adjuster.

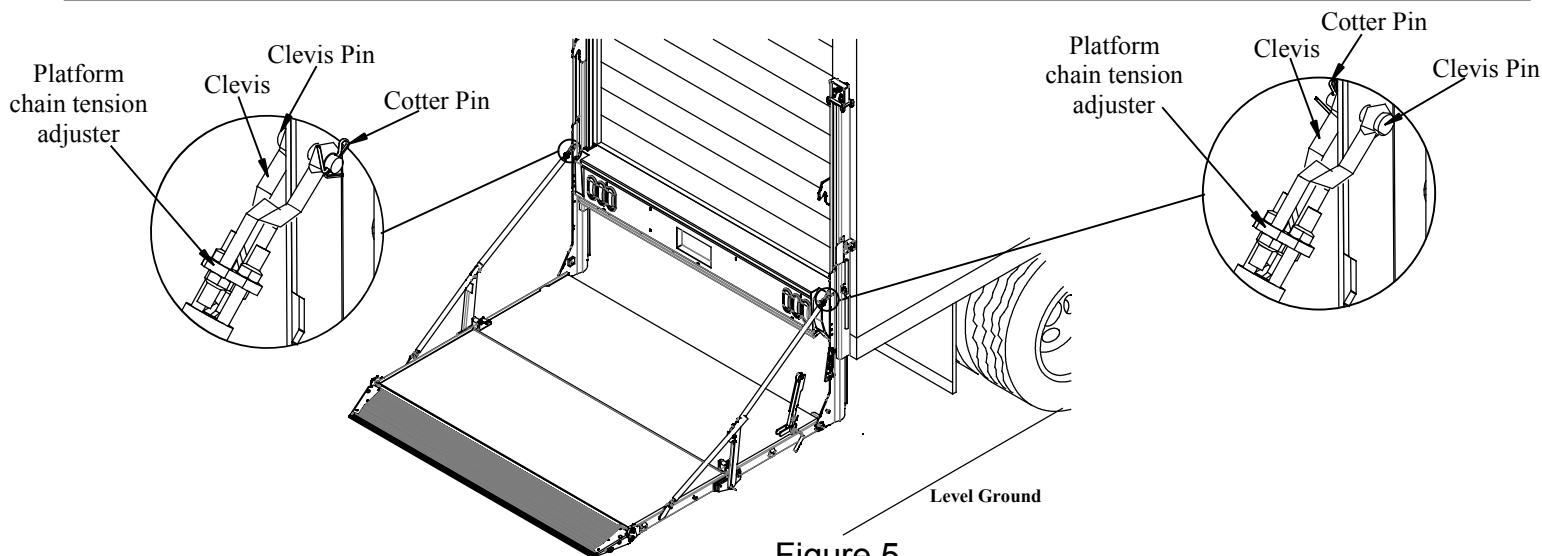

Figure 5