

Note: Connecting liftgate lights to the truck's trailer tow harness may disable park aid features on trucks with trailer detection capabilities. To avoid this, it may be necessary to connect to the truck's tail light wiring or trailer tow harness using a relay. Tommy Gate offers a relay kit (PN 15863) for these situations. The relay kit minimizes the amount of electrical load on the vehicle's factory wiring. See page 5 for more information.

Preparing the Kit

1. **Verify** kit (Figure 1, Table 1).
2. **Locate** the license plate light and mounting hardware in the maintenance manual kit (Figure 1, Table 1).
3. **Prepare** the 12V light relay kit, if installing it.

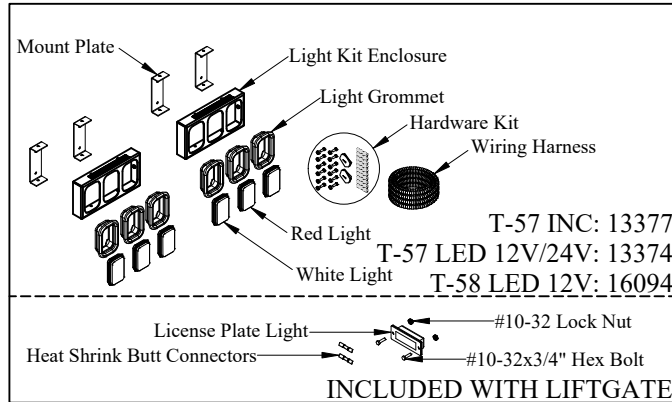

Figure 1: Part Identification.

Table 1: Parts List

QTY.	PART NO.	DESCRIPTION
2	10737	3-Light Kit Enclosure
6	4062	Light Grommet
4	4064	Red Light (LED)
	4065	Red Light (INC)
	15533	Red Light (LED)
2	4063	White Light (LED)
	4078	White Light (INC)
	15534	White Light (LED)
4	10736	Mount Plate
1	9103	Hardware Kit
1	9143	Wiring Harness
1	3050	License Plate Light
2	9089	Heat Shrink Butt Connector
2	1485	#10-32x3/4" Hex Bolt
2	556	#10-32 Lock Nut

Preparing the Liftgate

1. **Lower** the liftgate to the ground.
2. **Disconnect** the power cable from the positive side of the battery or manually **Trip** the circuit breaker (Figure 2).
3. **Remove** the mainframe box cover by removing the three 5/16" hex nuts with a 1/2" wrench or socket (Figure 3).
4. **Remove** two (2) 1 1/4" and four (4) 1/4" hole plugs from access holes (Figure 4).

Note: If the plugged holes are not present in the box cover, drill them as shown (Figure 5).

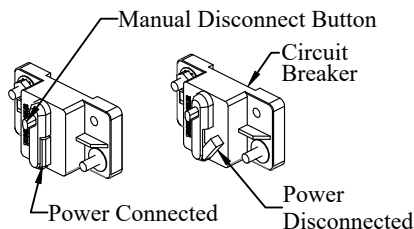

Figure 2: Circuit Breaker

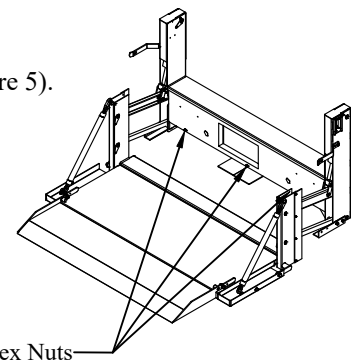

Figure 3: Assembled Liftgate

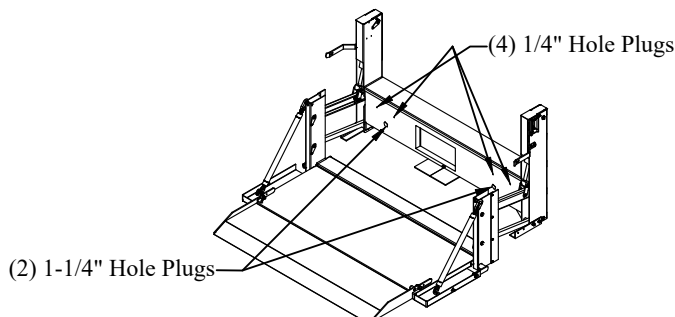

Figure 4: Plugged Mounting Holes

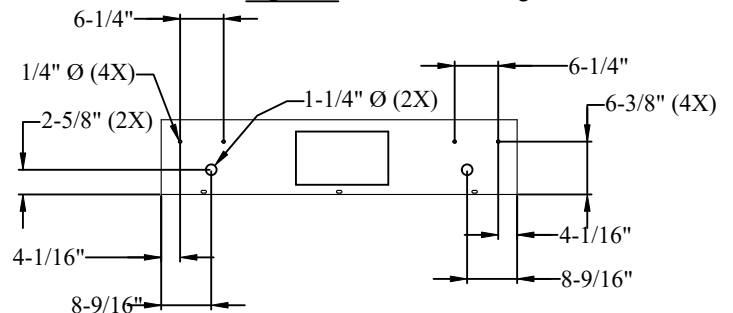

Figure 5: Drilled Hole Locations on Older Liftgates

Assembling the Box Cover

1. **Loosely Attach** two (2) mount plates to the back of each enclosure using two (2) 1/4-20 nuts and bolts per mount plate (Figure 6).
 2. **Loosely Attach** each enclosure to the box cover using one (1) 1/4-20 nut and bolt through the upper hole of each mount plate (Figure 6).
- Note: Ensure the warning stickers are on top.
3. **Tighten** the twelve (12) nuts and bolts attached in steps 1 and 2.
 4. **Ensure** the rubber gasket is in place on the license plate light (Figure 6).
 5. **Mount** the License Plate Light using two (2) #10-32 nuts and bolts (Figure 6).

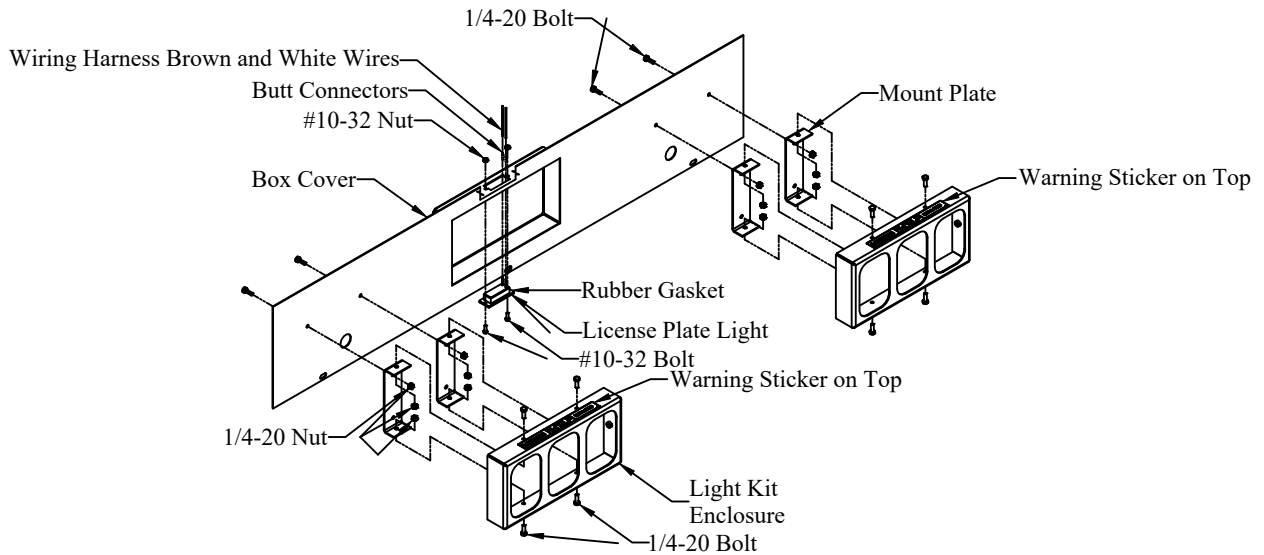

Figure 6: Box Cover Assembly

Running the Wiring

1. **Pull** two (2) 3-prong tail light plugs and a 2-prong tail light plug through each 1-1/4" access hole (Figure 4 or 5).
- Note: Ensure the LT/HAZ/TAIL plug is on the driver's side and the RT/HAZ/TAIL plug is on passenger's side.
2. **Cut** the 1 1/4" rubber grommets from the inner hole out (Figure 7).
 3. **Place** the 1 1/4" rubber grommets around wires (Figure 7)
 4. **Secure** the grommets inside the 1 1/4" holes (Figure 4).
 5. **Splice** the license plate light wires to one pair of the blunt-cut white and brown wires (Figure 6).
 6. **Seal** the remaining white and brown blunt-cut wires as shown (Figure 8).
 7. **Pull** the vehicle end wires, through an unused hole in the back of the liftgate, to the vehicle.

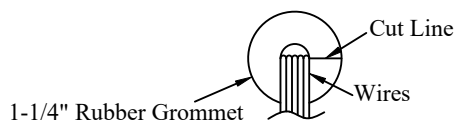

Figure 7: Wire Grommet

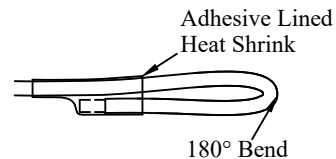

Figure 8: Sealed Wire End

G² dual drive® Light Kit Mounting Instructions

Installing the Lights

1. Press the light grommets into the large holes in the enclosures (Figure 9).
2. Pull harness plugs through the inserted grommets, matching the proper tail light configuration (Figure 10).
3. Connect the plugs to their lights (Figure 10).
4. Connect the provided wiring harness to the vehicle's existing wiring. Follow the recommended electrical guidelines when connecting the wiring harness to the vehicle.

Note: If using a relay kit, install it at this time by following the relay kit's installation instructions.

5. Verify and Correct proper operation of lights.

Note: If using a relay kit, reconnect power to the liftgate to operate the lights.

6. Firmly Push lights into installed rubber grommets until they are secured (Figure 9).
7. Tie the harness out of the way of moving components and sharp edges, using cable ties.
8. Reinstall the box cover on the liftgate and reconnect the liftgate's power.
9. Verify proper operation of lights.

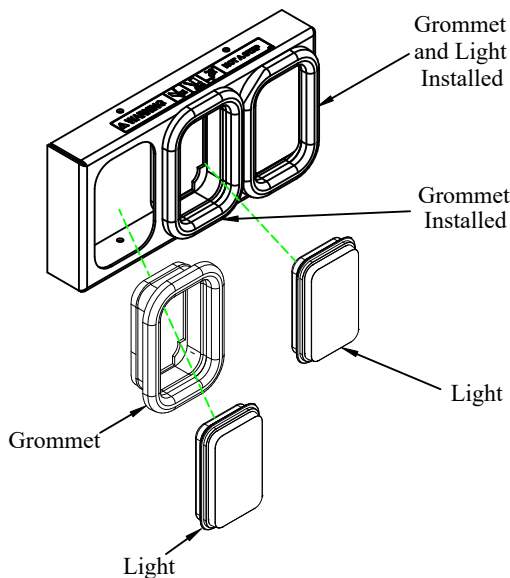

Figure 9: Light Kit Assembly

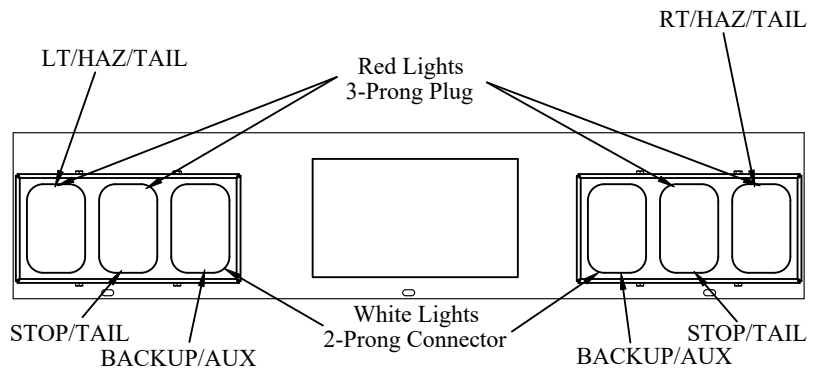

Figure 10: Light Functions and Colors

Electrical Guidelines:

- (1) The installer is responsible for using proper techniques when interfacing with vehicle electrical systems.
- (2) Failure to comply with the OEM guidelines could result in unsafe vehicle operation, failure of OEM wiring, or vehicle fire.
- (3) Never replace OEM fuses and/or circuit breakers with fuses or circuit breakers with a higher rating.
- (4) The total circuit current draw should not exceed 80% of the OEM circuit fuse or circuit breaker.
- (5) When possible, use body builder junction blocks, customer access circuits & connectors rather than extending OEM circuits.
- (6) Incorporate relays when extending the OEM electrical system.
- (7) Use appropriate gauge wire for extending circuits. The wire gauge should be capable of supporting the maximum load to which the added circuit will be exposed.
- (8) OEM electrical wire color coding should be maintained when extending circuits.
- (9) When adding circuits, always incorporate fuse or circuit breaker protection.

Note: ⊗ Symbol indicates usage of heat shrink butt connector.
 X Indicates wire is sealed away and not used (Figure 11).

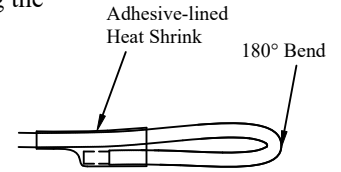
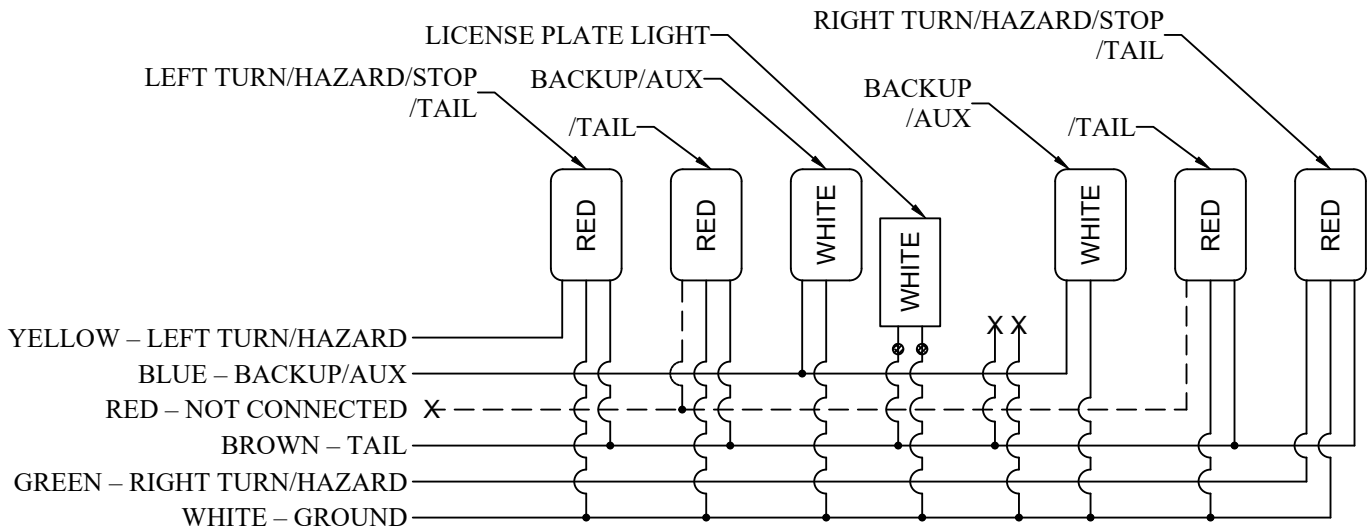
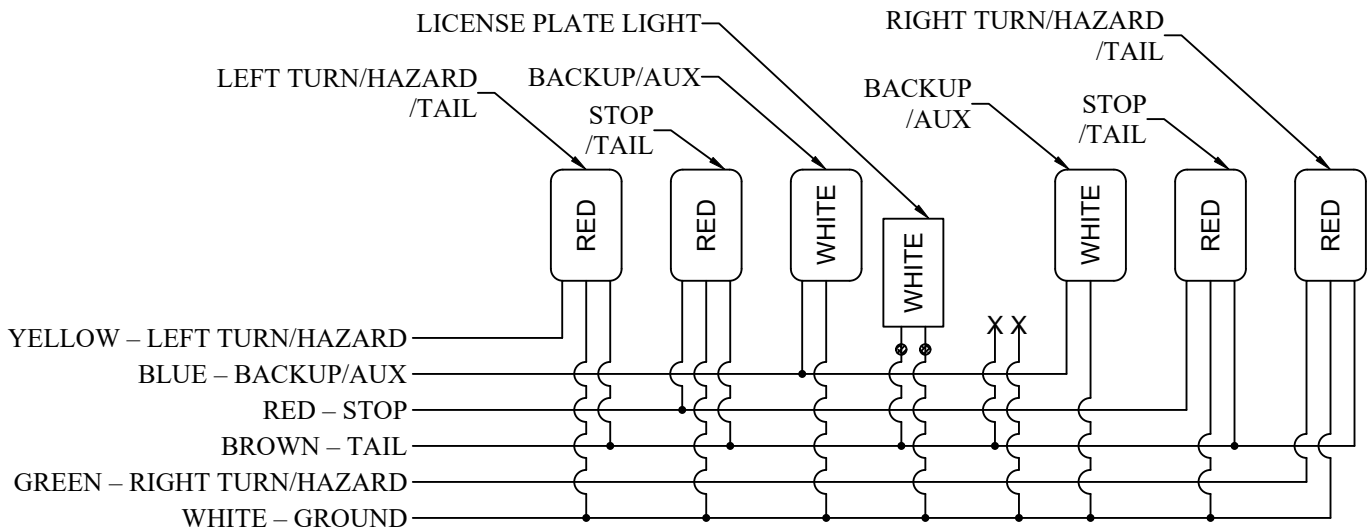

Figure 11: Sealed Wire End

COMBINED STOP/TURN FUNCTION



SEPARATED STOP/TURN FUNCTION



Tommy Gate 12V Light Relay Kit -PN 015863 (Sold Separately)

Connecting liftgate lights to the truck's trailer tow wiring may disable park aid features on trucks with trailer detection capabilities. To avoid this, it may be necessary to connect to the truck's tail light harness or trailer tow harness using a relay. Tommy Gate offers a relay kit (PN 15863) for these situations. This relay kit minimizes the amount of electrical load on the vehicle's factory wiring.

If your truck is listed in the table below and has a trailer detection system, use of a light relay kit (PN 15863) is recommended.

Table 2: Recommended Relay Applications

PICKUP MFG	YEAR	MODEL	AVAILABLE TRAILER DETECTION SYSTEM	RECOMMENDED WIRING LOCATION WITH RELAY
CHEVY	2019-2022	1500	ADVANCED TRAILERING SYSTEM	TAIL LIGHT HARNESS
	2020-2022	2500 / 3500		
FORD	2019-2022	RANGER	SMART TRAILER TOW CONNECTOR	TAIL LIGHT HARNESS
	2015-2022	F-150		
	2016-2022	SUPER DUTY SERIES		
GMC	2019-2022	1500	PROGRADE TRAILERING SYSTEM	TAIL LIGHT HARNESS
	2020-2022	2500 / 3500		

Notes:

Compatible with both combined (2-wire) and separated (3-wire) stop/turn vehicle systems

Compatible with 12-volt applications only