

Full-size Ford Trucks-
 F-150 (Includes Hybrid): 2015-present
 F-150 Lightning (Pro and XLT only) see pages 13-14 for details: 2022-present

Preparing the Gate

1. Remove the mounting hardware which is banded to the liftgate.
2. Verify mounting bracket kit (Figure 1 and Table 1).

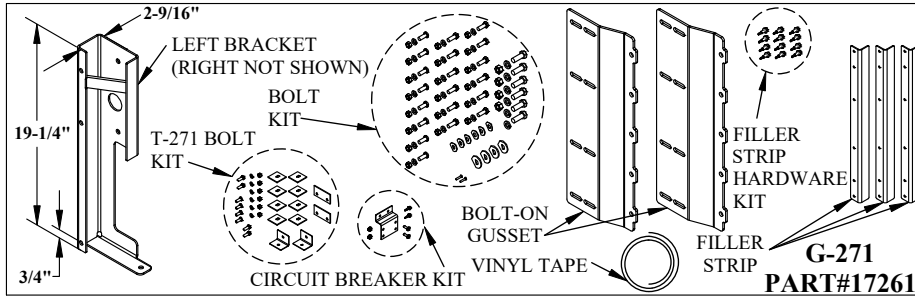

Figure 1: G-271 Part Identification.

Table 1: G-271 Parts List.

QTY.	PART NO.	DESCRIPTION
1	9094	Standard Pickup Bracket Bolt Bag Kit
1	17243*	T-271 Left Corner Bracket
1	17244*	T-271 Right Corner Bracket
1	17262	T-271 Bolt Kit
2	6343	Standard Bolt-on Gusset
3	15910*	Filler Strip
1	14196	Circuit Breaker Bracket Kit
140"	14240	2" Vinyl Tape
1	16296	Filler Strip Hardware Kit

* Indicates galvanized part

3. Support the liftgate; it will not stand upright without the angle irons.
4. Unbolt and Save the two (2) angle irons attached to the liftgate uprights (Figure 2).
5. Remove and Save the two (2) bracket plates attached to the liftgate (Figure 2).

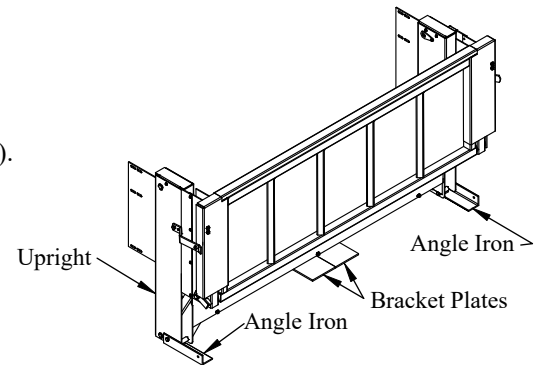

Figure 2: Complete liftgate.

Installing the Bolt-on Gussets

1. Install the eight (8) 3/8" x 1" button head bolts, lock washers, and nuts in the position shown for your configuration (Figure 3).
 - Bolt-on gussets and button head bolts go to the outside of the 1/4" x 1" strip.

Note: The extra hole in the bolt-on gusset is always below the 1/4" x 1" strip (Figure 4).

Note: If gussets are already welded to the uprights, you do not need the bolt-on gussets.

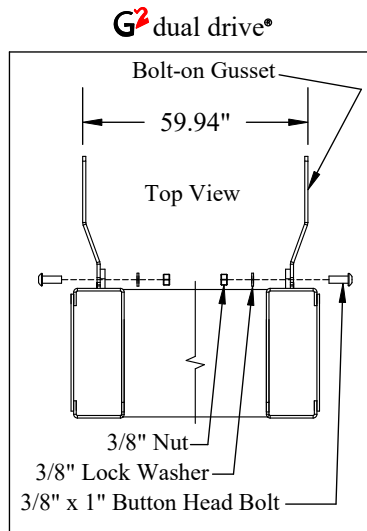

Figure 3: Top view of liftgate bolt-on gussets.

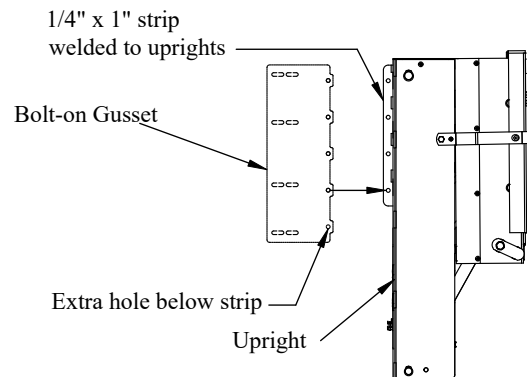

Figure 4: Liftgate requiring bolt-on gussets.

Preparing the Truck

1. **Remove** the tailgate (Figure 5).
2. **Remove** and **Save** the tailgate strikers (Figure 5). Each striker has a washer that will be reused.
3. **Drill** out the center hole of the striker's washer with a 0.406" diameter drill bit (Figure 6).
4. **Install** a supplied M10x1.5 hex head bolt along with a drilled striker washer in the locations where the strikers were removed.
5. **Support** the rear bumper and hitch to keep them from falling while removing the mounting bolts.
6. **Remove** the rear bumper, bumper mounting brackets, and hitch.

Note: The tailgate, hitch, and rear bumper cannot be remounted after the liftgate is installed.

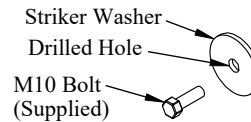

Figure 6: Striker washer.

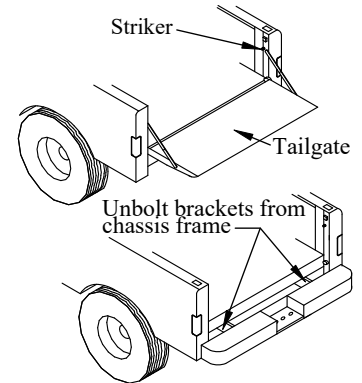

Figure 5: Remove hardware.

Modifying the Tail Light Mounting

Note: No modification is needed for 2015-present model year trucks. The factory tail light screws can be removed after the liftgate is installed by using an 8mm wrench.

Installing the Filler Strip

Note: A filler strip may be needed if installing a G² Series with an aftermarket hitch on an F-150. Three 12ga. x 19-1/2" angle filler strips are included in this kit for this purpose. Note: The filler strip must be mounted on the liftgate before the liftgate is mounted on the truck.

1. **Arrange** the three (3) filler strips along the top corner of the liftgate mainframe (Figure 10). Position the flange without holes horizontal.
2. **Attach** the filler strips to the mainframe with the provided twelve (12) self drilling screws. Avoid obstructions (hoses, wires, decals, etc) inside the mainframe while attaching filler strips.

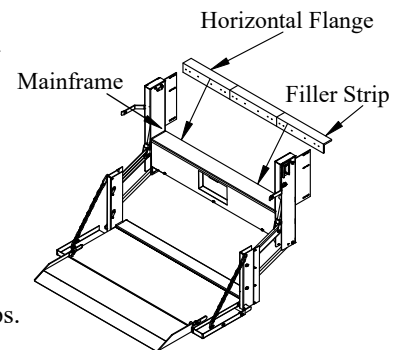

Figure 7: Filler strip location.

Installing the Vinyl Tape

Note: The supplied vinyl tape is used to separate the steel brackets/liftgate from the aluminum truck body. This is needed because galvanic corrosion may occur when the two different metals are in contact with each other.

1. **Clean** the surfaces of the brackets and under side of the filler strip of dirt, oil, grease, salt, or other contamination.
2. **Apply** the vinyl tape to the corner brackets as shown (Figure 8).
3. **Apply** the vinyl tape to the angle braces as shown (Figure 9)
4. **Apply** the remaining vinyl tape the the under side of the filler strip (Figure 7).
5. **Cut** vinyl tape around cargo light button hole on driver side bracket, if needed (Figure 8).

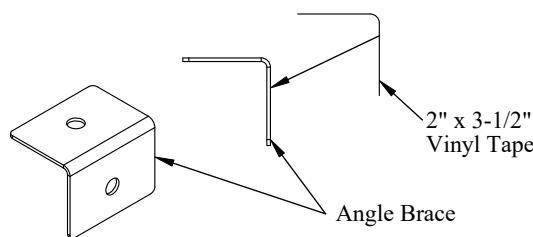

Figure 9: Vinyl tape locations.

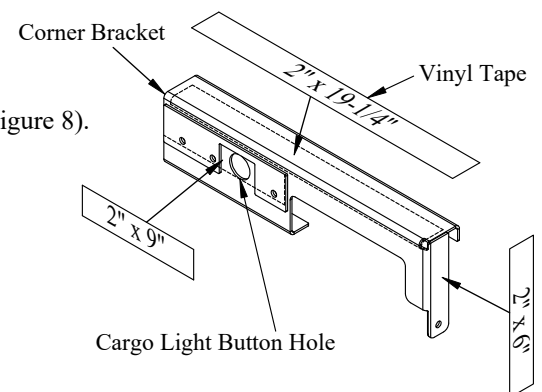

Figure 8: Vinyl tape locations.

Installing the Angle Braces

1. **Verify** that vinyl tape has been applied to the angle braces.
2. **Position** each angle brace flush with the rear of the truck bed, where the truck bed meets the corner post (Figure 10).
3. **Remove** the tail lights.
4. **Check** for obstructions before drilling in the next step.
5. **Drill** 3/8" diameter holes in the truck, using the angle brace holes as a guide.
6. **Install** the angle braces on the truck using the 3/8" button head bolts, aluminum backer plates, lock washers, and nuts (Figure 10).

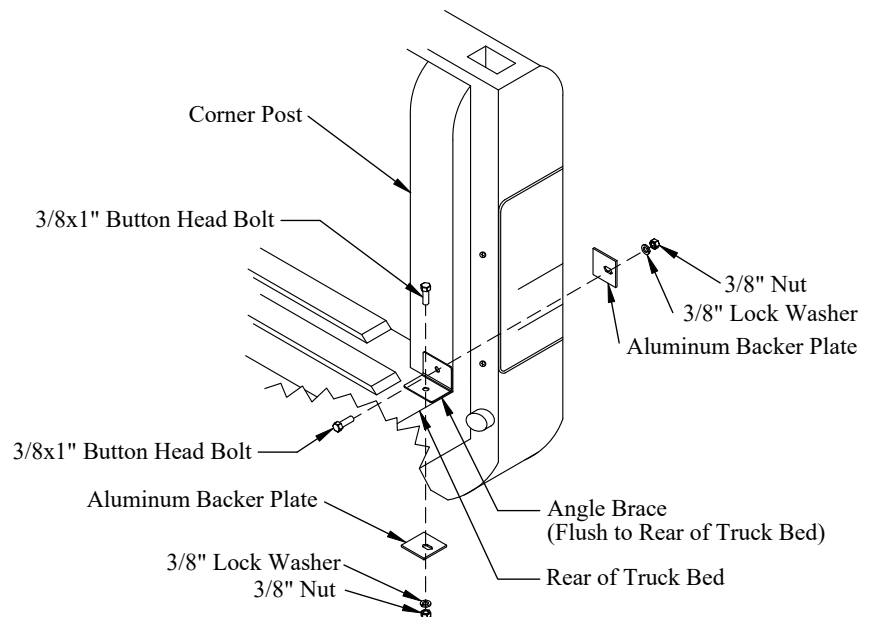

Figure 10: Angle brace location.

Installing the Liftgate

Note: Aftermarket receiver hitches should be installed before mounting the liftgate to avoid interference.

1. **Verify** that vinyl tape has been applied to the brackets and filler strip.
2. **Position** the mounting brackets into the truck bed in front of the corner posts (Figure 10).
Do not drill holes for mounting brackets at this time.
3. **Position** the Tommy Lift into the bed opening. The liftgate should be:
 - Aligned with spare tire tube.
 - Centered in the opening.
 - Flush with the truck bed floor.
 - In a vertical position (level with the ground).
4. **Hand tighten** each mounting bracket to the liftgate gussets using the supplied:
 - (3) 3/8"x1" hex head bolts on the bracket-side (Figure 11).
 - (3) 3/8" lock washers, and (3) 3/8" nuts on the gusset-side (Figure 11).
5. **Allow** the liftgate to hang, supported by the corner posts.
6. **Hold** the bracket against the corner post.
7. **Check** for obstructions before drilling in the next steps.
8. **Drill** a 3/8" hole into the truck bed floor using the hole in the bracket as a guide (Figure 12).

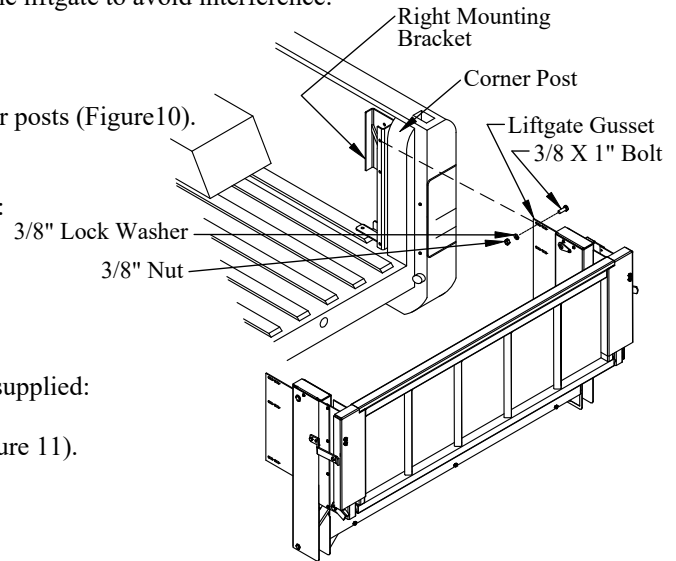

Figure 11: Mounting bracket and liftgate.

Note: When attaching the steel brackets to the aluminum truck, use only the supplied zinc plated hardware and aluminum washers. Do not use stainless steel hardware.

9. **Fasten** each bracket to the truck box using the supplied (Figure 12):
 - 3/8"x1" hex head bolt on the top-side.
 - backer plate, lock washer, and hex nut on the under-side.
10. **Drill** three (3) 3/8" holes into the truck inner box side using three holes in the bracket as a guide (Figure 13).
11. **Fasten** each bracket to the truck inner box side using the supplied (Figure 13):
 - (3) 3/8"x1" hex head bolts on the bracket-side.
 - (2) backer plates, (3) lock washers, and (3) hex nuts on the truck-side.

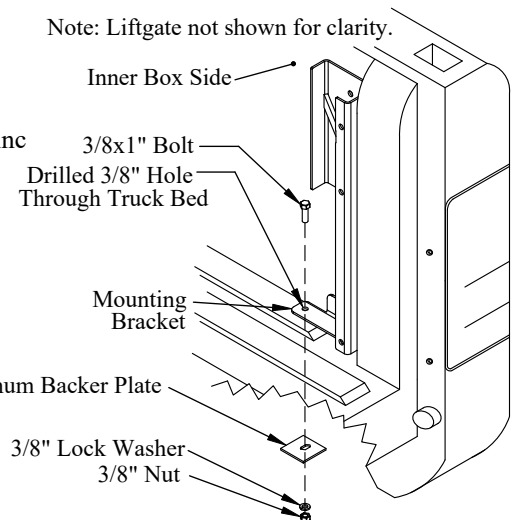

Figure 12: Mounting bracket and backer plates.

12. **Adjust** the liftgate so the platform is level from front to back.
Check the clearance between the truck tail light lenses and the liftgate.

13. **Tighten** the bolts securing the liftgate gusset to the mounting brackets. The lock washer split must not be in the gusset slot when tightening bolts.

14. **Install** the tail lights.

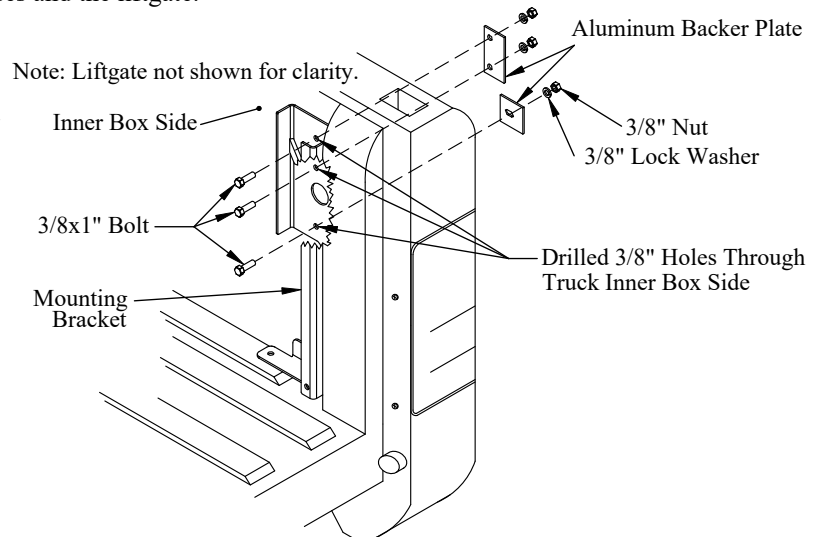
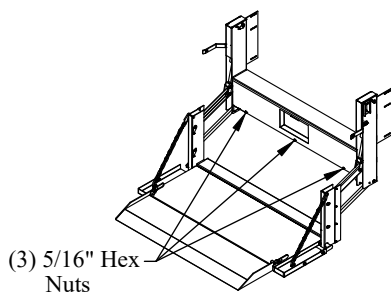

Figure 13: Mounting bracket and backer plates.

Checking the Spare Tire Access

Note: There are holes in the mainframe that provide access to the spare tire crank mechanism.

1. **Remove** the box cover by removing the 5/16" hex head nuts or bolts (Figure 14).
2. **Remove and Discard** the black plastic plug(s) from the mainframe in the location shown (Figure 15).
3. **Verify** spare tire access operation by inserting the spare tire crank rod through the access holes.



(3) 5/16" Hex Nuts

Figure 14: Box cover locations.

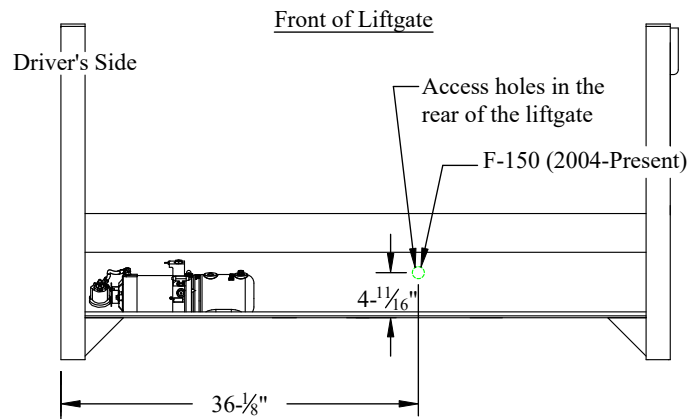

Figure 15: Spare tire access.

Preparing the Gate for Wiring

1. **Unscrew** the solid plastic plug from the pump reservoir. The box cover should already be off.

Note: The hydraulic system has already been filled with the proper amount of hydraulic oil so **do not** add any oil at this time.

2. **Attach** 12 volts from a battery to the liftgate power cables (no battery chargers).

3. **Push** the hidden "Power On" switch (Figure 19). The amber "Power On" LED will illuminate.

4. **Push** the hidden "Liftgate Activated" switch twice within one second. The red "Liftgate Activated" LED will illuminate.

Note: With both lights on, the liftgate can be raised or lowered. If not used for 90 seconds, the control will automatically shut off.

5. **Push** the toggle switch down to lower the liftgate to the ground.

6. **Remove** the following from inside the liftgate mainframe:

- Owner/Operator Manual
- License plate light
- License plate light hardware
- (1) Vent plug
- (1) 150 Amp manual reset circuit breaker
- (4) Copper lugs
- (2) License plate nuts and screws
- (1) Padlock with keys
- (3) 3/8" plastic plugs
- (1) Drop away pin
- (1) Lower mounting kit

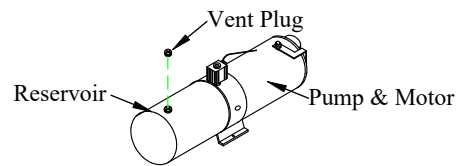

Figure 16: Vent plug.

7. **Install** the vent plug provided into the pump reservoir (Figure 16).

Routing the Power Cables

Note: For Ford Lightning see pages 13-14 regarding required auxiliary battery, charger, and other components.

1. **Install** the circuit breaker on the circuit breaker bracket with 1/4" screws and nuts (Figure 17).

2. **Install** the circuit breaker on the plastic flange of the battery tray, inside the engine compartment away from moving parts. Leave enough room for the power cables to be installed and so that the circuit breaker can easily be reset.

3. **Loosen** the strain relief on the back of the liftgate mainframe (Figure 18).

4. **Pull** the power cable (coiled up in the liftgate mainframe) carefully through the strain relief. Leave approximately two (2) inches of slack inside the liftgate mainframe (Figure 18).

5. **Tighten** the strain relief.

6. **Route** the power cables along frame (Figure 18) to the battery following *Tommy Gate Recommended Electrical Wiring Guidelines*.

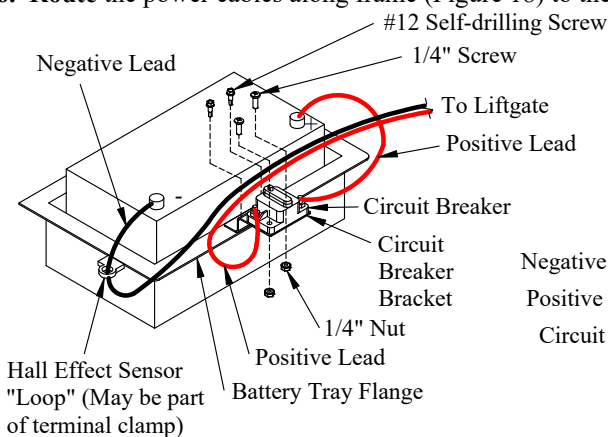

Figure 17: Circuit breaker bracket.

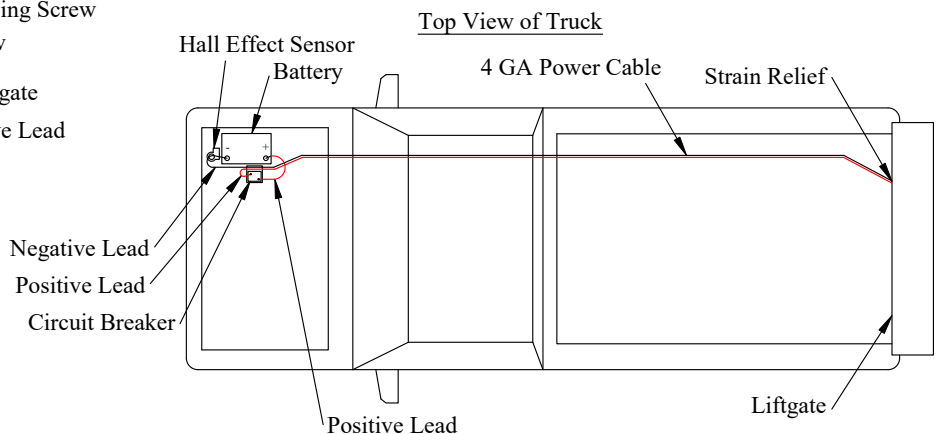

Figure 18: Electrical routing.

Routing the Power Cables (continued)

7. Pull the excess cable beyond the battery.
8. Separate the positive(+) and negative(-) leads.
9. Cut the positive(+) lead to the length required to reach the auxiliary (AUX) terminal of the circuit breaker.
10. Cut the remaining pos.(+) lead long enough to reach from the circuit breaker battery (BAT) terminal to the pos.(+) battery terminal.
11. Cut the negative(-) lead to a length required to pass through the vehicle hall effect sensor and reach the negative battery terminal.

Note: The liftgate ground must pass through the "loop" of the hall effect sensor (Figures 17 & 19). The "loop" may be part of the terminal clamp. Not doing so will affect the charging system and shorten battery life (Ford Bulletin Q-231).

IMPORTANT: The pump and motor unit for this lift can require significant electrical power at 12 volts D.C. Be sure that the negative(-) ground lead is connected to the negative(-) terminal of the vehicle battery.

12. Install the copper lugs and heat shrink tubing on all required ends.
13. Connect the circuit breaker and battery as outlined in the *Tommy Gate Recommended Electrical Wiring Guidelines* and wiring diagram (Figure 19).

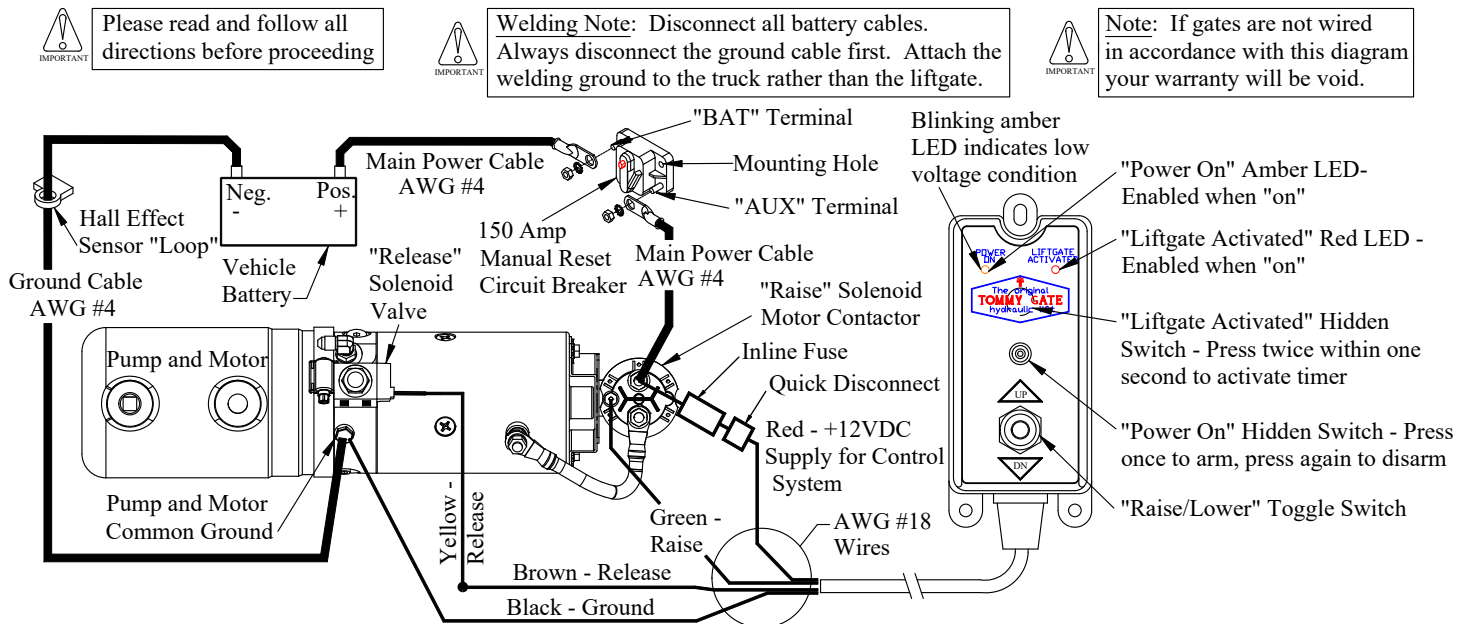
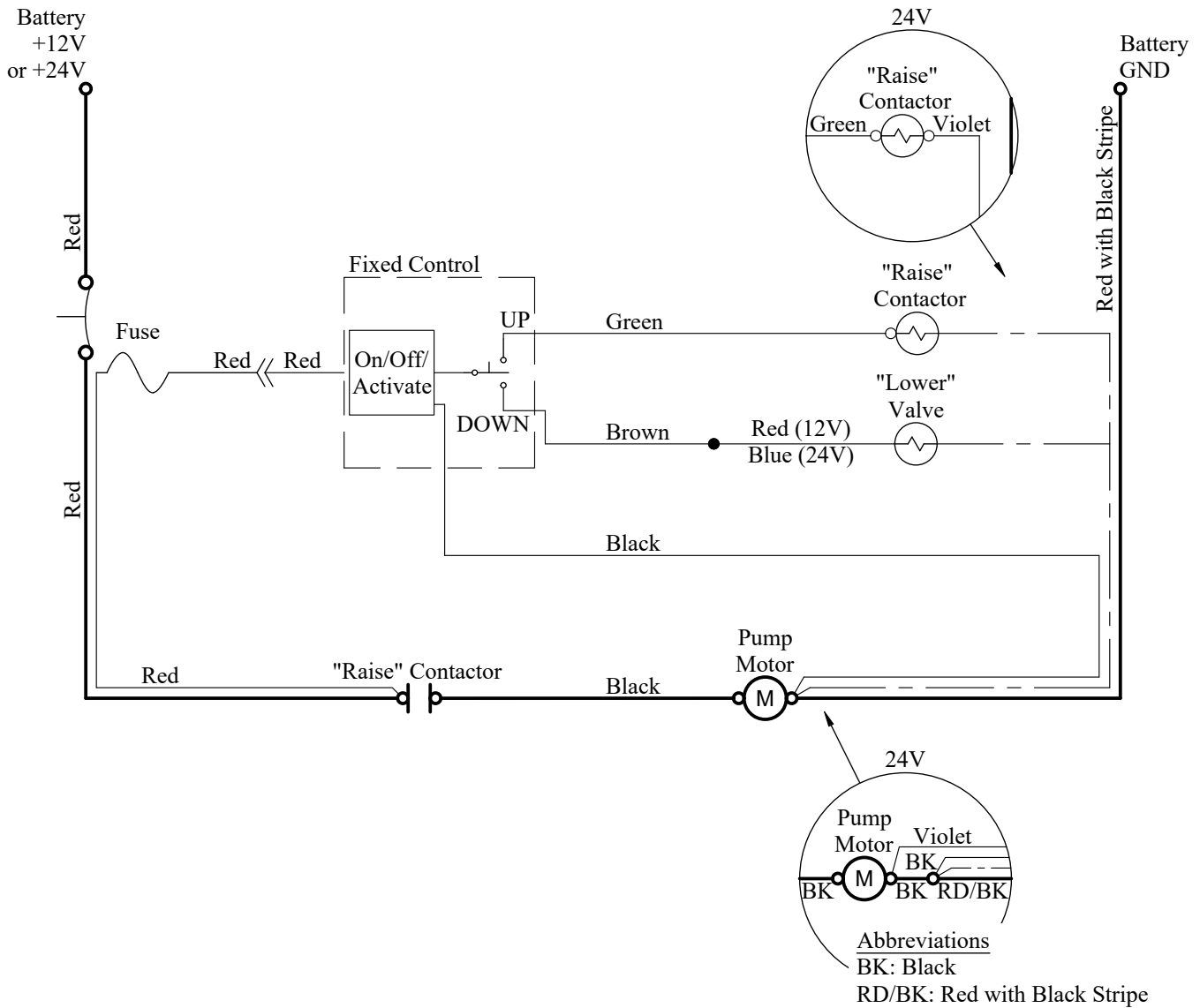

Figure 19: Wiring diagram.

Ladder Logic/Wiring Diagram

Legend	
	Circuit Breaker
	Contactor - Normally Open Contacts
	Motor
	Solenoid/Contactor - Coil
	Battery Cable
	Wire
	Grounded through pump body.
	Eyelet Terminal
	Splice
	Quick Disconnect
	Fuse



Installing the Lower Mount

IMPORTANT: Do not install a liftgate on a pickup without installing the lower mount.

- 1. Install** the two (2) mounting angle irons to the bottom of the liftgate (Figure 20).
Select the holes in the liftgate that position the angle irons adjacent to the truck frame rails.

Note: Nuts have been welded to the inside of the liftgate to accept the bolts.
Note: If the liftgate already has a long angle iron, use it in place of the two mounting angle irons.

- 2. Bolt** the bracket plates to the truck frame (Figure 21).
Modification to the bracket plates may be required.
- 3. Clamp** the short angle irons to the bracket plates.
The short angle irons should extend out to the mounting angle irons on the liftgate.

- 4. Tack weld** the bracket plates (see welding note at right), the short angle irons, and the mounting angle irons together.

- 5. Remove** the tacked lower brackets from the truck.

- 6. Weld** all seams with a heavy weld:
 - Where the bracket plates meet the short angle irons.
 - Where the short angle irons meet the mounting angle irons.

- 7. Bolt** the completed brackets back to the truck frame and bottom of the liftgate.

Note: The lower mount is of great importance because it adds additional support to the liftgate.

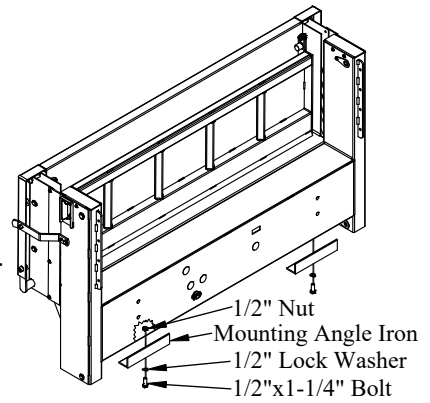

Figure 20: Mounting angle iron location.

WELDING NOTE!!! DISCONNECT ALL BATTERY CABLES. ALWAYS DISCONNECT THE GROUND CABLE FIRST. ATTACH THE WELDING GROUND TO THE TRUCK RATHER THAN THE LIFTGATE.

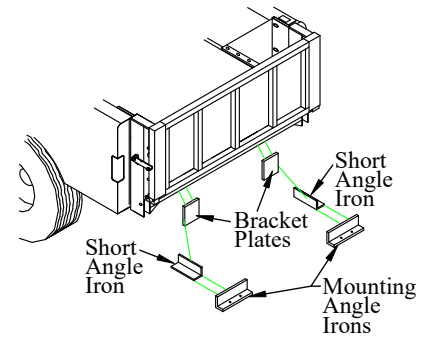

Figure 21: Lower bracket support.

Finishing the Liftgate Installation

- 1. Install** the two (2) square plastic insert nuts for the license plate into the square holes on the liftgate.
- 2. Install** the license plate using the two (2) stainless steel screws provided.
- 3. Install** the license plate light into the holes provided.
- 4. Connect** the license plate light(s) to the vehicle's wiring following the *Tommy Gate Recommended Electrical Wiring Guidelines*. The license plate light wire(s) can be run through the strain relief in the back of the liftgate.

Note: Additional wire may need to be spliced into the license plate light circuit to reach the connection point.
Note: All electrical splices should be heat shrunk for corrosion protection.

- 5. Install** the 3/8" round plastic plugs into the empty holes in the bottom of the uprights.
- 6. See** the Owner's / Operator's Manual if drop away feature is desired.
- 7. Install** the "Do's and Do Not's" decal in a highly visible area in the vehicle cab.
This decal is with the Owner's / Operator's Manual.
- 8. Reinstall** the spare tire, if previously removed.

Testing the Operation of the Liftgate

CAUTION: Keep all foreign objects (body parts, tools, load weights, etc) out of the liftgate mainframe and away from pinch points at all times when operating the liftgate.

1. **Check** operation of the safety control for proper lift operation.
Be sure the control shuts off automatically after 90 seconds of not being used.
2. **Raise** and **Lower** the unloaded platform on a flat surface looking for proper operating speed and alignment with the ground.
3. **Load** the platform with the rated capacity and **Measure** the time necessary to raise the platform.
The platform should raise at roughly 2-3 inches per second.
4. **Examine** the platform for any downward creep.
5. **Time** the lowering operation with the platform still loaded.
The load should descend at roughly 7-9 inches per second.
6. **Remove** the load from the platform and **Examine** the liftgate and vehicle for any problems such as hydraulic oil leaks, loose wiring, etc.
7. **Reinstall** the box cover.
8. **Close** and **Latch** the platform.
9. **Lock** the padlock through the hole in the latch pin (Figure 22).
10. **Place** Owner's / Operator's Manual and padlock keys in the vehicle.

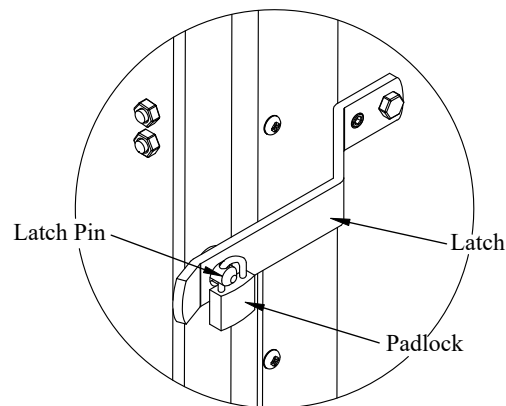

Figure 22: Padlock location.

Painting the Liftgate (if needed)

Your Tommy Gate has been primed with a gray polyurethane and painted with a black semi-gloss polyurethane topcoat to protect it from the environment. No additional paint is required unless shipping or installation damage or outdoor storage exposure has deteriorated the Tommy Gate paint. **Tommy Gate will not be responsible for shipping or installation damage or outdoor storage exposure that has marred or otherwise deteriorated the Tommy Gate paint.**

If you need to refinish the liftgate you should do the following:

1. **Remove** any dirt, oil, grease, salt, or other contamination by washing with a mild detergent solution.
2. **Rinse** thoroughly with fresh water and allow to dry.
3. Lightly **Scuff Sand** the Tommy Gate topcoat.
4. **Sand** and **Spot Prime** any area of the Tommy Gate paint that shows signs of damage or deterioration.
5. **Mask** off all safety decals, cylinder shafts and vents before painting.

WARNING: Paint overspray on the cylinder shaft(s) or vent(s) will damage the cylinder seals and void warranty.

6. After proper cleaning and surface preparation, **Apply** desired finish coat per paint manufacturer's recommendations.
7. **Remove** the masking from the safety decals and cylinders.
8. **Check** to ensure that all decals are clean and legible. Additional decals are available from the factory, if needed.

WIRE ROUTING

- (1) When routing wires, avoid heat (above 180°F), abrasion, vibration, metal edges, screws, and trim fasteners. If such routings are not possible, protective devices must be used. If wires must cross a metal edge, the edge should be covered with a protective shield and the wiring fastened within 3 inches on each side of the edge.
- (2) Grommets must be used where wires pass through holes in sheet metal, castings, and / or frame rails. Do not bend wires in a radius smaller than 10 times the wire diameter.
- (3) Routing wires into areas exposed to wheel wash should be avoided. If this cannot be avoided protective shields are required to protect the wires from stones, ice, salt and water damage. Provide a drip loop to prevent moisture from being conducted into switches, relays, circuit breakers, and fuses.
- (4) Wires should be supported every 18 inches with plastic zip ties or rubber-lined clips.
- (5) Wires must be routed to clear moving parts by at least 3 inches unless positively fastened or protected by a conduit. If wiring must be routed between two members where relative motion can occur, the wiring should be secured to each member, with enough wire slack to allow flexing without damage to the wire.
- (6) Maintain at least a 6 inch clearance from exhaust system components. If this is not possible, high temperature insulation and heat shields are required. Existing OEM heat shields, insulation, and wire shielding must be maintained.
- (7) Do not route or attach electrical wires to fuel lines. Route electrical wires at least 1-1/2 inches away from the engine.

BATTERY, WIRE, TERMINALS, AND CONNECTORS

- (1) Wire attachments at the battery must be protected from tension loads so there is no undue strain on the battery terminals. Wires should be routed down rather than horizontally from the terminals with no sharp bends adjacent to the connections.
- (2) Battery power for your Tommy Gate should come directly from the battery through the supplied circuit breaker or fuse. The circuit breaker or fuse should be installed as close to the battery as possible.
- (3) Do not splice battery cables. If splicing is necessary, the most durable splice joint will be bare metal barrel crimped, flow-soldered and covered with adhesive lined heat shrink tubing. Strip the wire ends making sure that individual conductor strands are not damaged. Use only rosin core solder, proper crimping tools, and wire with a gauge at least equivalent to the circuit being lengthened. Do not use electrical tape.
- (4) Battery cable terminals will be bare metal barrel crimped or flow-soldered and covered with adhesive lined heat shrink tubing.
- (5) Use wire connectors with locking features such as positive locking, inertia locking, bolt together, and soft mold-over with locking external retainers.

GENERAL

- (1) All frame contact areas must be wire brushed to bare metal, free of paint, dirt, and grease. Frame connections must be made using hardened flat washers under the bolt head and lock nuts. Corrosion preventive grease or compound is to be applied to the terminal area of the frame connection.
- (2) Frame cross members are not recommended as part of the ground return.
- (3) All circuit breakers and fuses should be located in one easily serviceable location with a means provided for identification of circuit function and current rating. Do not put circuit breakers or fuses in the vehicle cab.
- (4) Before welding to the chassis disconnect the battery. Also disconnect the power train, engine, valve, and transmission control modules.
- (5) Do not alter vehicle ignition, starting, and / or charging systems. Do not reroute engine compartment wiring.
- (6) Full copper circuitry and standardized polarity grounds are recommended.
- (7) Never increase the rating of a factory installed fuse or circuit breaker.
- (8) Disconnect the battery negative (ground) wire prior to any vehicle modification.

Following the above guidelines will provide you with years of trouble free service. Failing to incorporate the above guidelines will result in a voided warranty. Non-compliance with the guidelines above may result in a failure of electrical components, shutdown of engines, loss of backup brake systems, and the possibility of fire.

Ford F-150 Lightning Liftgate Power Connections & Recommendations



2022 Ford F-150 Lightning: Pro and XLT Trims Only

The 12 volt (12V) battery in the all-electric Ford F-150 Lightning is significantly smaller than the 12V battery in a typical gasoline powered truck. For this reason, Ford does not allow a liftgate to be connected directly to this battery. Tommy Gate recommends installing an auxiliary 12V battery and DC-DC charger in the Lightning's Frunk to power the liftgate (specific recommendations below). The auxiliary 12V battery is sized larger than the Lightning's 12V battery so that it can provide sufficient power demanded by the liftgate. The DC-DC charger electrically isolates the two battery systems.

What is a DC-DC Charger?

A DC-DC charger is an automatic battery charger that is powered by another battery instead of a common AC outlet. In the case of the F-150 Lightning, the added DC-DC charger is taking power from the Lightning's 12V battery and slightly increasing the voltage to charge the auxiliary 12V battery. It continually monitors the condition of the auxiliary battery and alters the output that best suits the auxiliary battery. DC-DC chargers come in a variety of different voltage/ampere ratings, so it is important to choose the right one for the application. The DC-DC charger recommended below is sized to follow Ford guidelines and have minimal demand on the Lightning's 12V battery.

Tommy Gate Recommended Components

1. DC-DC charger (Tommy Gate recommends RedArc BCDC1212T 12-amp charger or equivalent, see note A)
2. Auxiliary 12V battery (Tommy Gate recommends a 70 amp hour flooded, AGM, or gel type battery)
3. Aftermarket battery box
4. Plastic hose to vent auxiliary battery (see note B)

Notes:

- A. DC-DC Charger Specifications: 12 volt to 12 volt, Amp rating between 10 to 20 Amps.
- B. The auxiliary battery should be vented to a well ventilated area, such as in the Lightning's 12V battery compartment.

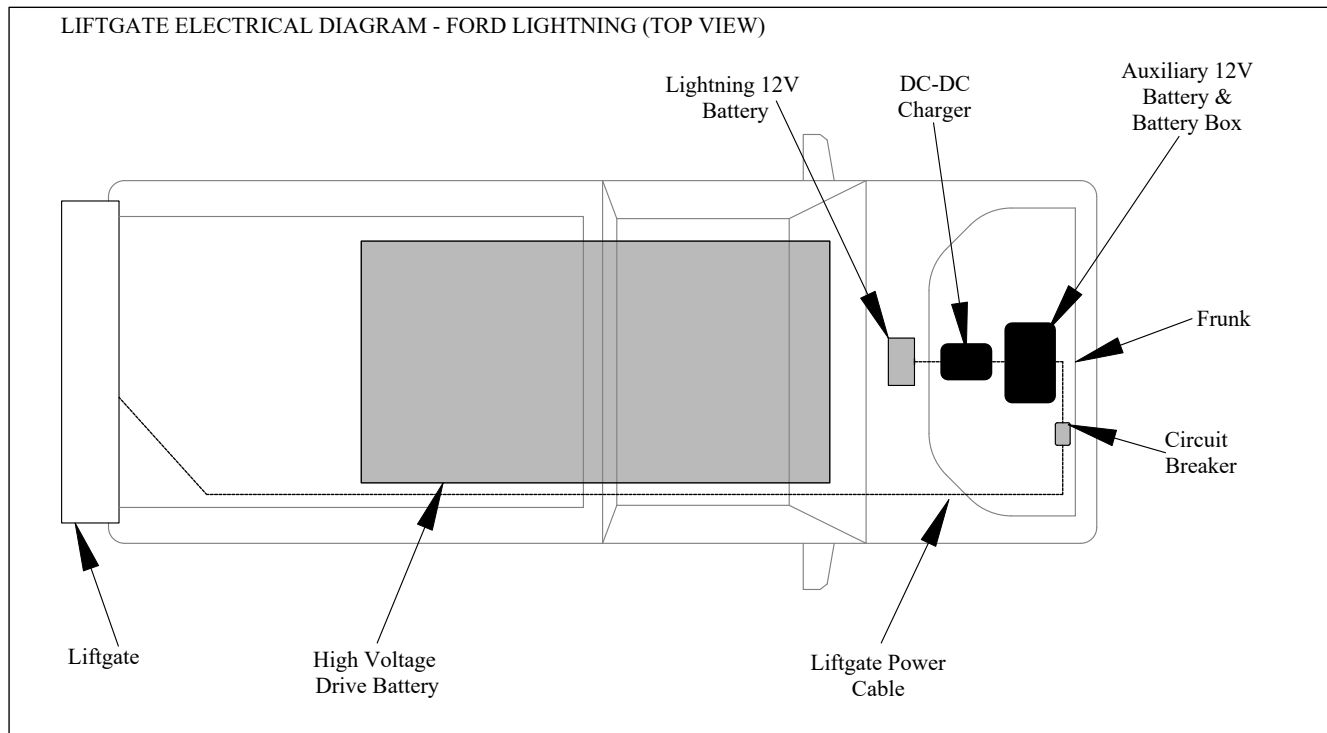



Body Builders Layout Book

26

F-150

F-150 LIGHTNING

BATTERY ELECTRICAL VEHICLE

2022

MODEL YEAR

12 VOLT AFTERMARKET ACCESSORY MOUNTING GUIDANCE

GUIDANCE PROVIDED IS LIMITED TO F-150 LIGHTNING PRO AND XLT ONLY (NOT APPLICABLE TO HIGHER LIGHTNING TRIM SERIES)

RECOMMENDATION:

- The 220A DC-DC converter and range battery pack standard on the F-150 Lightning Pro trim level can be used for applications that add aftermarket equipment such as lighting, radios, video, computers, video, spot lamps, surveillance, radar, etc.
 - There is a maximum of 55 Amps total available for aftermarket equipment for the F-150 Lightning Pro trim level.
 - There is a maximum of 30 Amps total available for aftermarket equipment for the F-150 Lightning BASE XLT trim level
 - Do not add 12V upfits to higher trim levels
 - The addition of a secondary 12 Volt Battery source is **not recommended**, please refer to the F-150 Police Responder Modifiers Guide, Section 2: Electrical, for further circuit details.

WARNING: Exceeding Rated Amps can result in degraded vehicle performance and/or impact to 12 Volt battery charge state.

- 2022MY Lightning Pro Electrical System overview can be found by referencing F-150 Police Responder Modifiers Guide (Section 2: Electrical, further circuit details), and Police Modifier Bulletin P-034 R1 (which includes information to access power, ground points and illustrations of selected high voltage components).
- Additional reference information on the High Voltage and Electrical Guidance found in the General Body Builder Layout Book.
- F-150 Lightning consists of various high-voltage components and wiring. All of the high-voltage power flows through specific wiring assemblies labeled as such or covered with a solid orange convolute, or orange striped tape, or both. Do not come in contact with these components

WARNING: This battery pack should only be serviced by an authorized electric vehicle technician. Improper handling can result in personal injury or death.

WARNING: Working in this area of the vehicle may result in serious personal injury or damage to a vehicle. Before working on this vehicle, the high voltage power must be disconnected