

# G<sup>2</sup> dual drive<sup>®</sup> and Original Series Pickup Lift Mounting Instructions

# T-170

Fullsize Chevy & GMC Trucks-  
 1500: 2007-2018 (Includes 2019 "LD" and "Limited")  
 2500 & 3500: 2007-2019  
 (Excludes 2007 "Classic")

## Preparing the Gate

1. Remove the mounting hardware which is banded to the liftgate.
2. Verify mounting bracket kit (Figure 1 and Table 1).

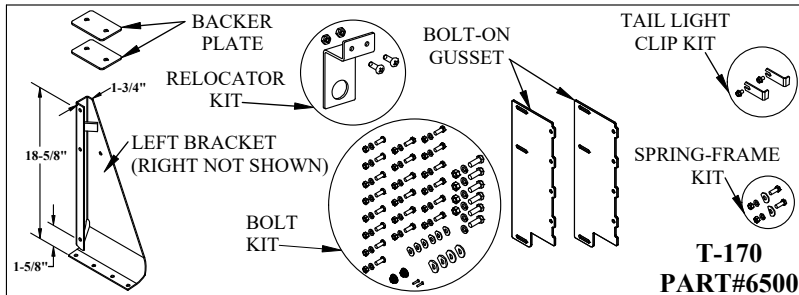

Figure 1: Part Identification.

Table 1: Parts List.

QTY.	PART NO.	DESCRIPTION
1	9094	Standard Pickup Bracket Bolt Bag Kit
1	4075	T-170 Left Corner Bracket
1	4076	T-170 Right Corner Bracket
1	5727	T-170/Tundra Tail Light Lens Clip Kit
1	5207	T-160/T-170 Tire Relocator Kit
1	9468	T-170 Spring-Frame Mount Bolt Kit
2	2943	T-170 Backer Plate
2	6344	T-170 Bolt-on Gusset

3. Support the liftgate; it will not stand upright without the angle irons- **G<sup>2</sup> only**.
4. **Unbolt** and **Save** the two (2) angle irons attached to the liftgate uprights- **G<sup>2</sup> only** (Figure 2).
5. **Remove** and **Save** the two (2) bracket plates attached to the liftgate- **G<sup>2</sup> only** (Figure 2).

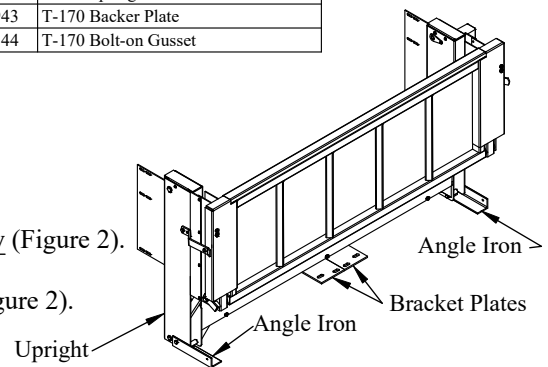

Figure 2: Complete liftgate (**G<sup>2</sup>** shown).

## Installing the Bolt-on Gussets

1. **Install** the eight (8) 3/8" x 1" button head bolts, lock washers, and nuts in the position shown for your configuration (Figure 3).
  - Original Series bolt-on gussets and button head bolts go to the inside of the 1/4" x 1" strip.
  - **G<sup>2</sup> dual drive<sup>®</sup>** bolt-on gussets and button head bolts go to the outside of the 1/4" x 1" strip.

Note: The cut-out in the bolt-on gusset is always below the 1/4" x 1" strip (Figure 4).

Note: If gussets are already welded to the uprights, verify that there are cut-outs in the gussets before proceeding (Figure 4).

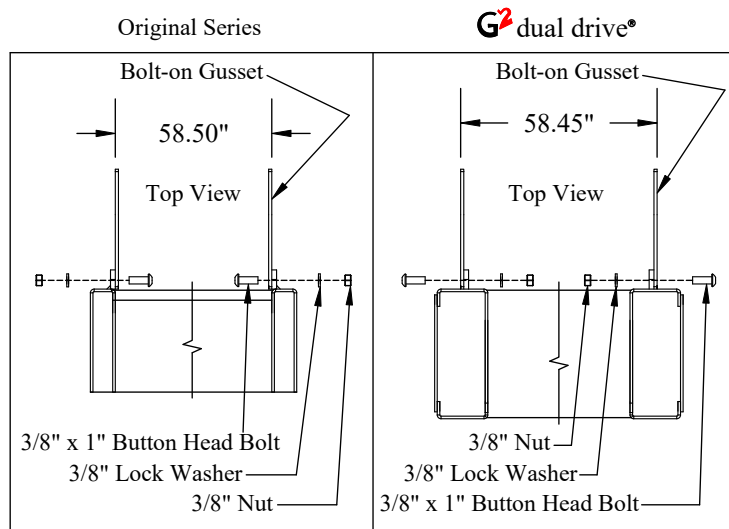

Figure 3: Top view of liftgate bolt-on gussets.

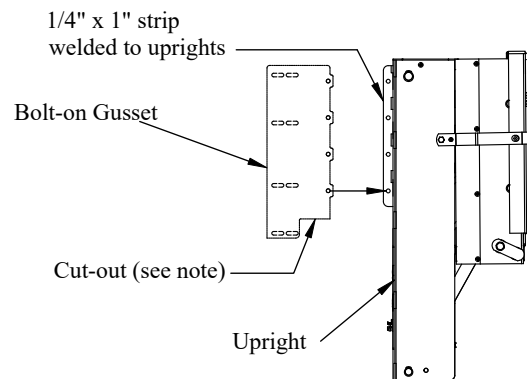

Figure 4: Liftgate requiring bolt-on gussets (**G<sup>2</sup>** shown).

## Preparing the Truck

1. **Remove** the locking spare tire access plug using the truck's ignition key (Figure 5).
2. **Remove** the spare tire using the proper tools that come with the truck.
3. **Remove** the tailgate and tailgate hardware (Figure 5).  
The strikers can be removed after the tail lights have been removed.
4. **Support** the rear bumper and hitch to keep them from falling while removing the mounting bolts.
5. **Remove** the hitch, if necessary. Check Tommy Gate hitch chart for compatibility.
6. **Unplug** the wiring clips that are connected to the rear bumper.
7. **Remove** the rear bumper. Re-wire side marker lights on dual rear wheel trucks, if they are disconnected in this step.

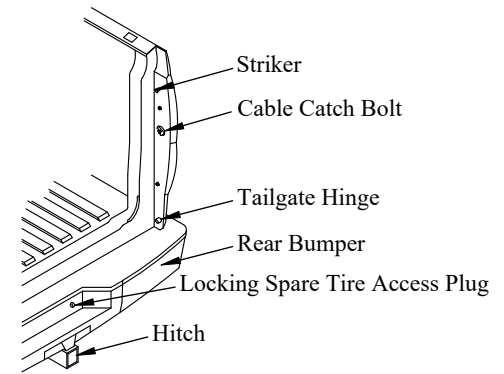

Figure 5: Remove hardware.

Note: The tailgate, tailgate hardware, hitch (if removed), and rear bumper cannot be remounted after the liftgate is installed.

8. **Install** fasteners from the T-170 Spring-Frame Mount Bolt Kit in the empty spring shackle-frame mount hole.  
Do this step only if bolts were removed from the leaf spring shackles while removing the bumper.
9. **Reinstall** any hardware attaching the hitch to the frame (if hitch is compatible). For cases where the bumper included the nut, reuse the original bolt (Metric 10.9 grade) with a thick washer and locking nut.

## Modifying the Tail Light Mounting

Note: After this modification, the M8x1.25x12 bolts can be loosened to remove the tail light lenses.

Note: This modification must be completed before the liftgate is installed so that the tail light bulbs can be replaced without removing the liftgate.

1. **Remove** four (4) factory tail light screws, two (2) per side (Figure 6).
2. **Remove** tail light lenses (Figure 6).
3. **Verify** that all tailgate hardware has been removed.
4. **Install** the tail light lenses leaving out factory screws.
5. **Install** M8 x 1.25 x 12 bolts and tail light clips (supplied) in the tailgate cable catch bolt locations (Figure 6).
6. **Apply** pressure to the tail light from the rear while tightening the bolt (Figure 6).

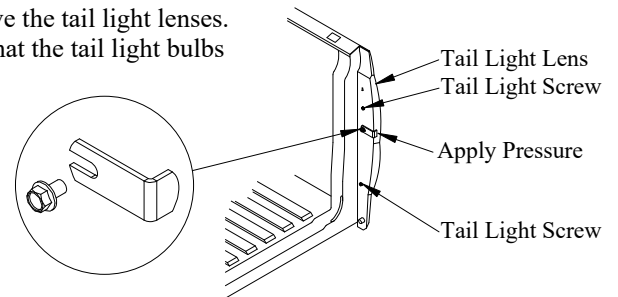

Figure 6: Tail light modification detail.

## Installing the Spare Tire Tube Holder

Note: This modification allows access to the spare tire crank mechanism after the liftgate is installed.

1. **Position** the supplied spare tire tube holder on the rear inside lip of the box (Figure 7).  
The spare tire tube should extend through the 1" hole of the tube holder.
2. **Mark** two (2) 1/4" hole locations on the truck body using the tube holder as a guide.
3. **Check** for obstructions and **Drill** two (2) 1/4" holes in the positions marked in step 2.
4. **Fasten** the tube holder with the supplied two (2) 1/4"x3/4" bolts and locking nuts.
5. **Remove** and **Discard** the black plastic plug in the rear of the liftgate for spare tire tube access (Figure 11).

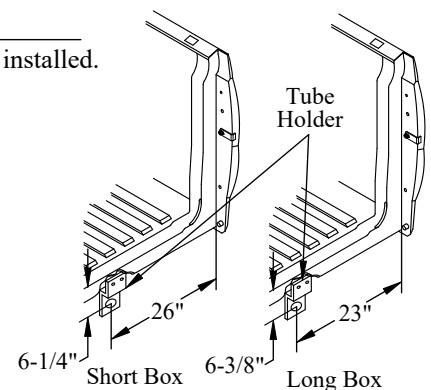

Figure 7: Tube holder location.

**Installing the Filler Strip (Original Series Only)**

Note: The filler strip must be mounted on the liftgate before the liftgate is mounted on the truck.

Note: The filler strip will fill the gap between the liftgate and the truck bed.

1. **Weld** the supplied filler strip (12ga.x1-1/4"x58-1/2") to the top corner of the liftgate mainframe (Figure 8).

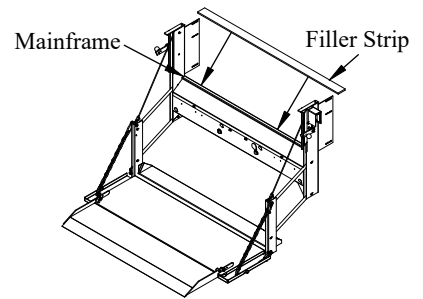

Figure 8: Filler strip location (Original Series).

**Installing the Liftgate**

1. **Position** the two mounting brackets into the truck bed in front of the corner posts (Figure 9).  
Do not drill holes for mounting brackets at this time.
2. **Position** the Tommy Lift into the bed opening. The liftgate should be:
  - Aligned with spare tire tube.
  - Centered in the opening.
  - Flush with the truck bed floor.
  - In a vertical position (level with the ground).

3. **Hand tighten** each mounting bracket to the liftgate gussets using the supplied:
  - (3) 3/8"x1" hex head bolts on the bracket-side (Figure 9).
  - (3) 3/8" lock washers, and (3) 3/8" nuts on the gusset-side (Figure 9).

Note: Flat washers **must** be added under bracket to fill any bed to bracket gap (Figure 10).

4. **Allow** the liftgate to hang, supported by the corner posts.
5. **Hold** the bracket against the corner post.
6. **Check** for obstructions before drilling in the next steps.
7. **Drill** two (2) 3/8" holes into the truck bed floor using the two holes (closest to the front of the truck) in the bracket as a guide (Figure 10).
8. **Fasten** each bracket to the truck box using the supplied:
  - (2) 3/8"x1" hex head bolts on the top-side (Figure 10).
  - (1) backer plate, (2) lock washers, and (2) hex nuts on the under-side (Figure 10).

9. **Drill** a 3/8" hole through the inner box side using the bracket's hole as a guide (Figure 10).
10. **Fasten** each mounting bracket to the inner box side using the supplied:
  - (1) 3/8" lock washer and (1) 3/8" nut on the bracket-side (Figure 10).
  - (1) 3/8"x1" hex head bolt and (1) 3/8" flat washer on the truck-side (Figure 10).

11. **Adjust** the liftgate so the platform is level from front to back.  
Check the clearance between the truck tail light lenses and the liftgate.
12. **Tighten** the bolts securing the liftgate gusset to the mounting brackets.  
The lock washer split must not be in the gusset slot when tightening bolts.

13. **Check** for clearance between the truck tail light lenses and the liftgate.

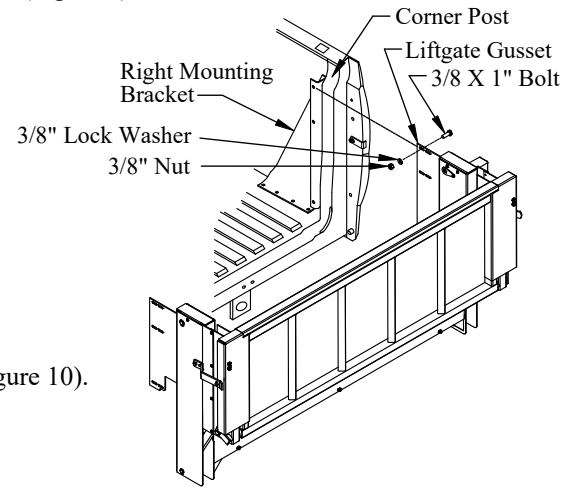

Figure 9: Mounting bracket and liftgate.

Note: Liftgate not shown for clarity.

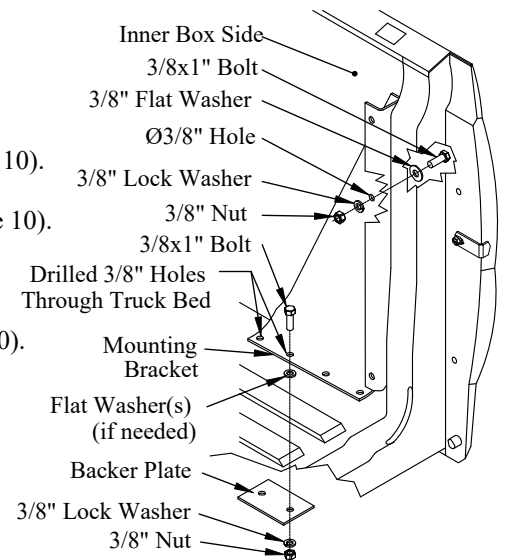

Figure 10: Mounting bracket hardware.

Checking the Spare Tire Access

Note: There are holes in the mainframe that provide access to the spare tire crank mechanism.

1. **Remove** the box cover by removing the 5/16" hex head nuts or bolts (Figure 11).
2. **Remove and Discard** the black plastic plug(s) from the mainframe at the location shown (Figure 12).
3. **Verify** spare tire access operation by inserting the spare tire crank rod through the access hole(s).

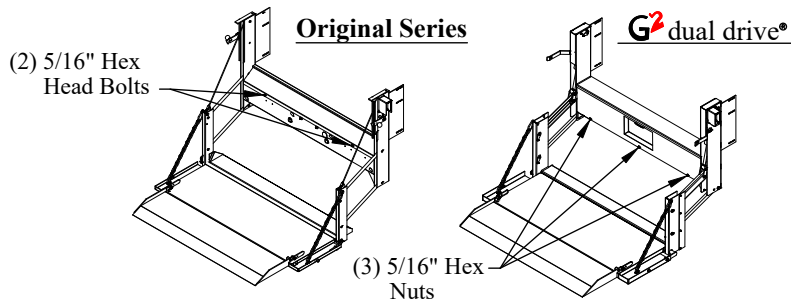

Figure 11: Box cover locations.

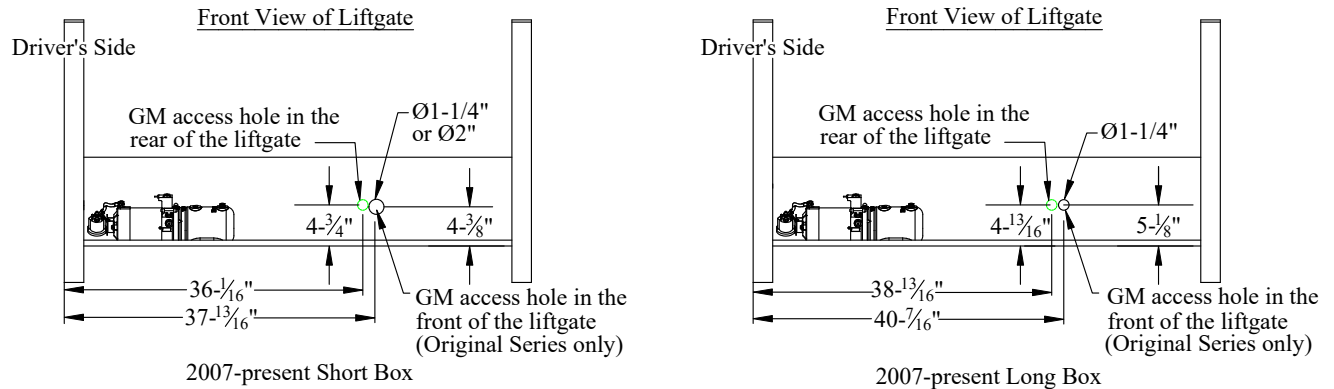

Figure 12: Spare tire access holes.

**Preparing the Gate for Wiring**

1. **Unscrew** the solid plastic plug from the pump reservoir. The box cover should already be off.

Note: The hydraulic system has already been filled with the proper amount of hydraulic oil so **do not** add any oil at this time.

2. **Attach** 12 volts from a battery to the liftgate power cables (no battery chargers).

3. **Push** the hidden "Power On" switch (Figure 15). The amber "Power On" LED will illuminate.

4. **Push** the hidden "Liftgate Activated" switch twice within one second. The red "Liftgate Activated" LED will illuminate.

Note: With both lights on, the liftgate can be raised or lowered. If not used for 90 seconds, the control will automatically shut off.

5. **Push** the toggle switch down to lower the liftgate to the ground.

6. **Remove** the following from inside the liftgate mainframe:

- Owner/Operator Manual
- License plate light(s)
- License plate light hardware
- (1) Vent plug
- (2) Latch balls with studs (Original Series only)
- (1) 150 Amp manual reset circuit breaker
- (4) Copper lugs
- (2) License plate nuts and screws
- (1) Padlock with keys
- (5) 3/8" plastic plugs (G<sup>2</sup> only)
- (1) Drop away pin
- (1) Lower mounting kit

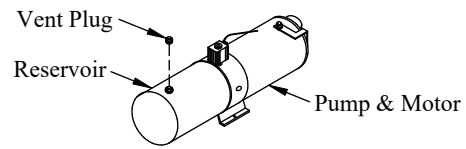

Figure 13: Vent plug.

7. **Install** the vent plug provided into the pump reservoir (Figure 13).

**Routing the Power Cables**

1. **Install** the circuit breaker on the vehicle fender, firewall, or other location inside the engine compartment away from moving parts. Leave enough room for the power cables to be installed and so that the circuit breaker can easily be reset.

2. **Loosen** the strain relief on the back of the liftgate mainframe (Figure 14).

3. **Pull** the power cable (coiled up in the liftgate mainframe) carefully through the strain relief. Leave approximately two (2) inches of slack inside the liftgate mainframe (Figure 14).

4. **Tighten** the strain relief.

5. **Route** the power cables along the frame (Figure 14) to the battery following the *Tommy Gate Recommended Electrical Wiring Guidelines*.

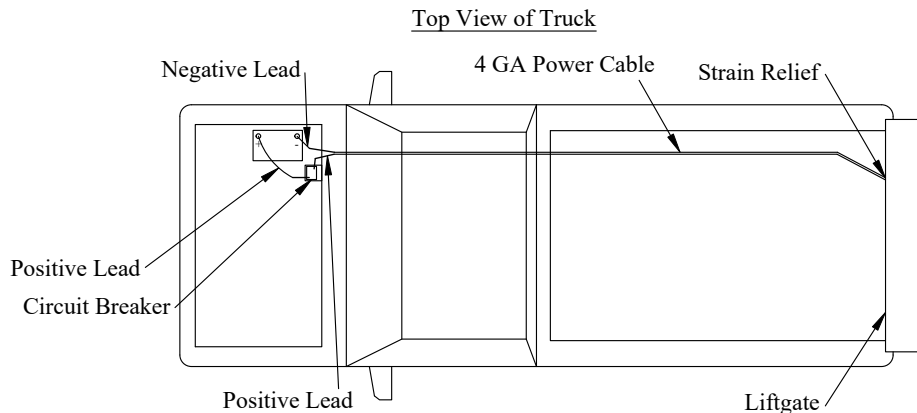

Figure 14: Electrical routing.

Routing the Power Cables (continued)

6. Pull the excess cable beyond the battery.
7. Separate the positive(+) and negative(-) leads.
8. Cut the positive(+) lead to the length required to reach the auxilliary (AUX) terminal of the circuit breaker.
9. Cut the remaining pos.(+) lead long enough to reach from the circuit breaker battery (BAT) terminal to the pos.(+) battery terminal.
10. Cut the negative(-) lead to the length required to reach the negative battery terminal.

**IMPORTANT:** The pump and motor unit for this lift can require significant electrical power at 12 volts D.C.  
Be sure that the negative(-) ground lead is connected to the negative(-) terminal of the vehicle battery.

11. Install the copper lugs and heat shrink tubing on all required ends.
12. Connect the circuit breaker and battery as outlined in the *Tommy Gate Recommended Electrical Wiring Guidelines* and wiring diagram (Figure 15).

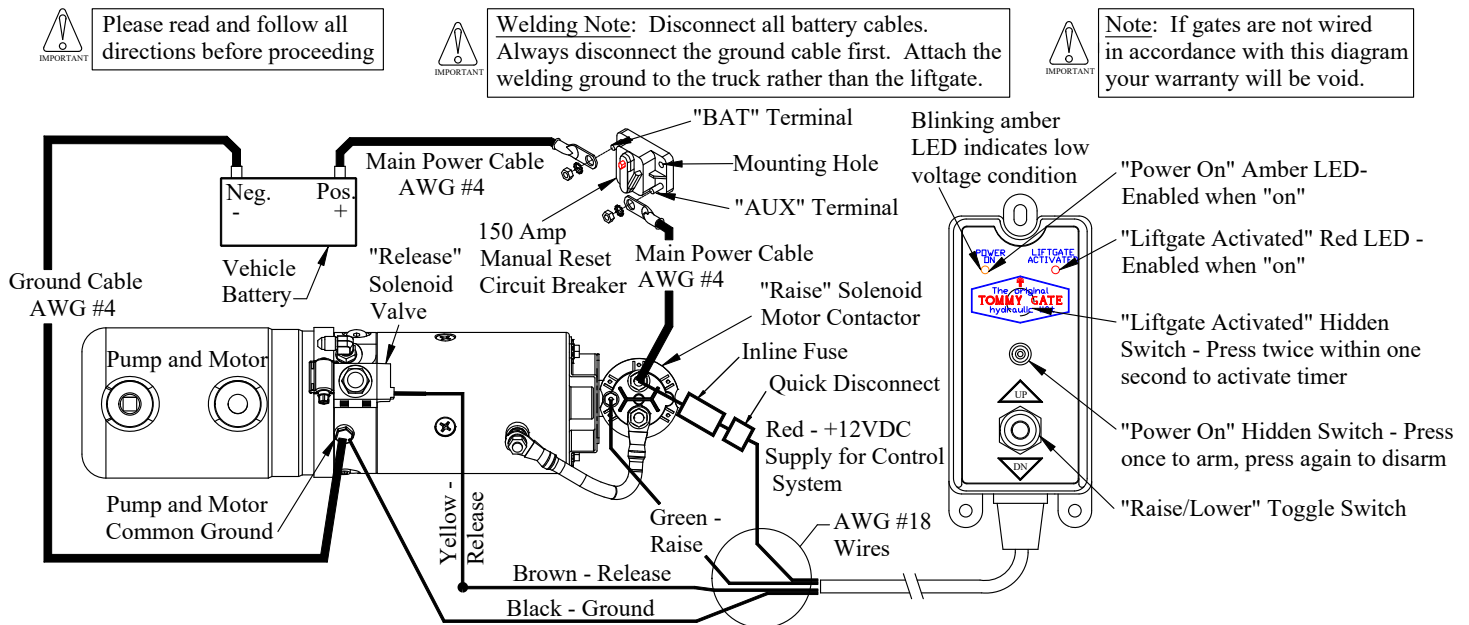
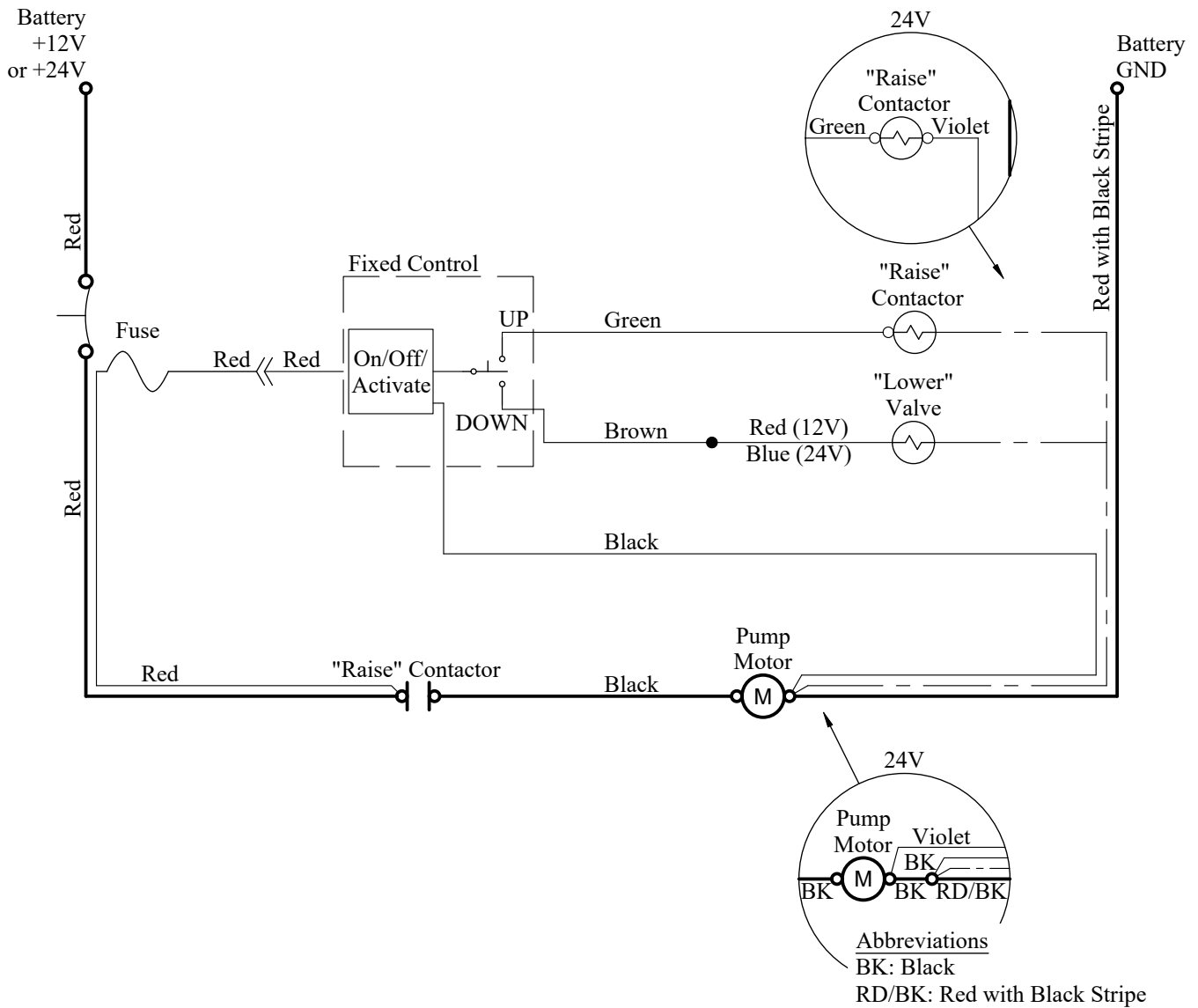

Figure 15: Wiring diagram.

Ladder Logic/Wiring Diagram

Legend	
	Circuit Breaker
	Contactors - Normally Open Contacts
	Motor
	Solenoid/Contactor - Coil
	Battery Cable
	Wire
	Grounded through pump body.
	Eyelet Terminal
	Splice
	Quick Disconnect
	Fuse



**Installing the Lower Mount**

**IMPORTANT:** Do not install a liftgate on a pickup without installing the lower mount.

- 1. Install** the two (2) mounting angle irons to the bottom of the liftgate (Figure 16).  
Select the holes in the liftgate that position the angle irons adjacent to the truck frame rails.

Note: Nuts have been welded to the inside of the liftgate to accept the bolts.  
Note: If the liftgate already has a long angle iron, use it in place of the two mounting angle irons.

- 2. Bolt** the bracket plates to the truck frame (Figure 17). If possible, these may extend out to the mounting angle irons on the liftgate. Modification to the bracket plates may be required.

- 3. Clamp** the short angle irons to the bracket plates, if needed to reach the mounting angle irons. The short angle irons should extend out to the mounting angle irons on the liftgate.

- 4. Tack** weld the bracket plates (see welding note at right), the short angle irons, and the mounting angle irons together.

- 5. Remove** the tacked lower brackets from the truck.

- 6. Weld** all seams with a heavy weld:
  - Where the bracket plates meet the short angle irons.
  - Where the short angle irons meet the mounting angle irons.

- 7. Bolt** the completed brackets back to the truck frame and bottom of the liftgate.

Note: The lower mount is of great importance because it adds additional support to the liftgate.

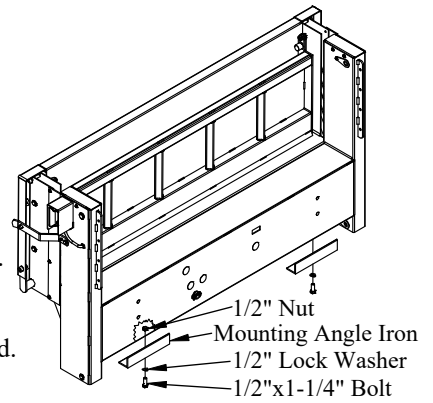

**Figure 16:** Mounting angle iron location.

**WELDING NOTE!!! DISCONNECT ALL BATTERY CABLES. ALWAYS DISCONNECT THE GROUND CABLE FIRST. ATTACH THE WELDING GROUND TO THE TRUCK RATHER THAN THE LIFTGATE.**

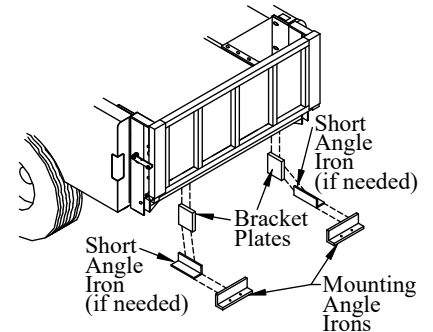

**Figure 17:** Lower bracket support.

**Finishing the Liftgate Installation**

- 1. Install** the two (2) knobs on the platform latches (Original Series only) see (Figure 18).
- 2. Install** the two (2) square plastic insert nuts for the license plate into the square holes on the liftgate.
- 3. Install** the license plate using the two (2) stainless steel screws provided.
- 4. Install** the license plate light(s) into the holes provided.
- 5. Connect** the license plate light(s) to the vehicle's wiring following the *Tommy Gate Recommended Electrical Wiring Guidelines*. The license plate light wire(s) can be run through the strain relief in the back of the liftgate.

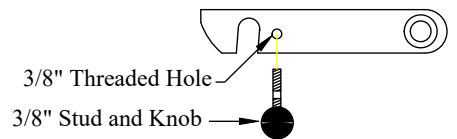

**Figure 18:** Original Series platform latch knob.

Note: Additional wire may need to be spliced into the license plate light circuit to reach the connection point.  
Note: All electrical splices should be heat shrunk for corrosion protection.

- 6. Install** the 3/8" round plastic plugs into the empty holes in the bottom of the uprights (**G<sup>2</sup>** only).
- 7. See** the Owner's / Operator's Manual if drop away feature is desired.
- 8. Install** the "Do's and Do Not's" decal in a highly visible area in the vehicle cab. This decal is with the Owner's / Operator's Manual.
- 9. Reinstall** the spare tire, if previously removed.



Testing the Operation of the Liftgate

**CAUTION:** Keep all foreign objects (body parts, tools, load weights, etc) out of the liftgate mainframe and away from pinch points at all times when operating the liftgate.

1. **Check** operation of the safety control for proper lift operation.  
Be sure the control shuts off automatically after 90 seconds of not being used.
2. **Raise** and **Lower** the unloaded platform on a flat surface looking for proper operating speed and alignment with the ground.
3. **Load** the platform with the rated capacity and **Measure** the time necessary to raise the platform.  
The platform should raise at roughly 2-3 inches per second.
4. **Examine** the platform for any downward creep.
5. **Time** the lowering operation with the platform still loaded.  
The load should descend at roughly 7-9 inches per second.
6. **Remove** the load from the platform and **Examine** the liftgate and vehicle for any problems such as hydraulic oil leaks, loose wiring, etc.
7. **Reinstall** the box cover.
8. **Close** and **Latch** the platform.
9. **Lock** the padlock through the hole in the platform or latch pin (Figure 19).
10. **Place** Owner's / Operator's Manual and padlock keys in the vehicle.

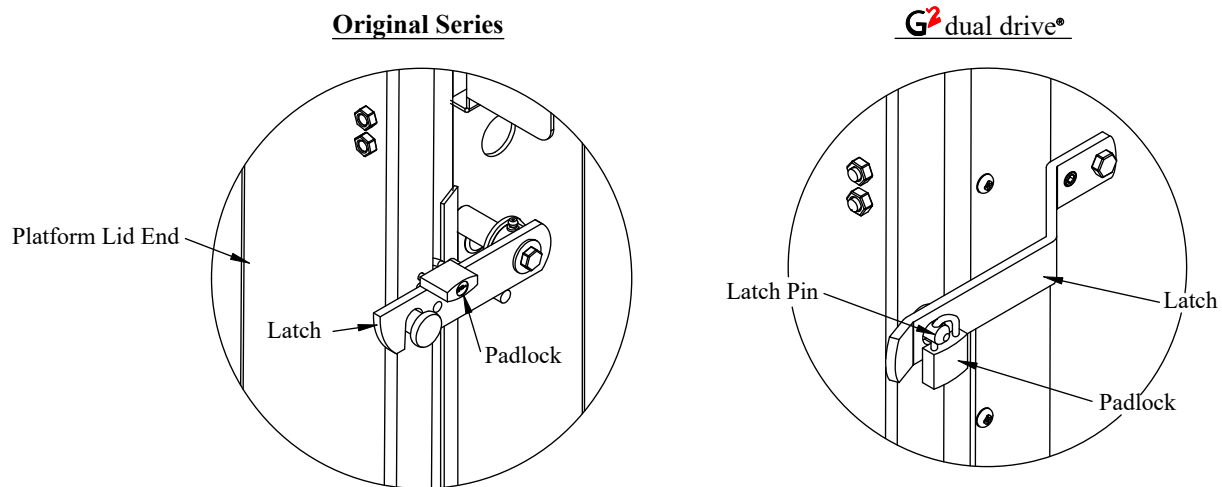

Figure 19: Padlock location.

### Painting the Liftgate (if needed)

---

Your Tommy Gate has been primed with a gray polyurethane and painted with a black semi-gloss polyurethane topcoat to protect it from the environment. No additional paint is required unless shipping or installation damage or outdoor storage exposure has deteriorated the Tommy Gate paint. **Tommy Gate will not be responsible for shipping or installation damage or outdoor storage exposure that has marred or otherwise deteriorated the Tommy Gate paint.**

If you need to refinish the liftgate you should do the following:

1. **Remove** any dirt, oil, grease, salt, or other contamination by washing with a mild detergent solution.
2. **Rinse** thoroughly with fresh water and allow to dry.
3. Lightly **Scuff Sand** the Tommy Gate topcoat.
4. **Sand** and **Spot Prime** any area of the Tommy Gate paint that shows signs of damage or deterioration.
5. **Mask** off all safety decals, cylinder shafts and vents before painting.

**WARNING:** Paint overspray on the cylinder shaft(s) or vent(s) will damage the cylinder seals and void warranty.

6. After proper cleaning and surface preparation, **Apply** desired finish coat per paint manufacturer's recommendations.
7. **Remove** the masking from the safety decals and cylinders.
8. **Check** to ensure that all decals are clean and legible. Additional decals are available from the factory, if needed.

## WIRE ROUTING

- (1) When routing wires, avoid heat (above 180°F), abrasion, vibration, metal edges, screws, and trim fasteners. If such routings are not possible, protective devices must be used. If wires must cross a metal edge, the edge should be covered with a protective shield and the wiring fastened within 3 inches on each side of the edge.
- (2) Grommets must be used where wires pass through holes in sheet metal, castings, and / or frame rails. Do not bend wires in a radius smaller than 10 times the wire diameter.
- (3) Routing wires into areas exposed to wheel wash should be avoided. If this cannot be avoided protective shields are required to protect the wires from stones, ice, salt and water damage. Provide a drip loop to prevent moisture from being conducted into switches, relays, circuit breakers, and fuses.
- (4) Wires should be supported every 18 inches with plastic zip ties or rubber-lined clips.
- (5) Wires must be routed to clear moving parts by at least 3 inches unless positively fastened or protected by a conduit. If wiring must be routed between two members where relative motion can occur, the wiring should be secured to each member, with enough wire slack to allow flexing without damage to the wire.
- (6) Maintain at least a 6 inch clearance from exhaust system components. If this is not possible, high temperature insulation and heat shields are required. Existing OEM heat shields, insulation, and wire shielding must be maintained.
- (7) Do not route or attach electrical wires to fuel lines. Route electrical wires at least 1-1/2 inches away from the engine.

## BATTERY, WIRE, TERMINALS, AND CONNECTORS

- (1) Wire attachments at the battery must be protected from tension loads so there is no undue strain on the battery terminals. Wires should be routed down rather than horizontally from the terminals with no sharp bends adjacent to the connections.
- (2) Battery power for your Tommy Gate should come directly from the battery through the supplied circuit breaker or fuse. The circuit breaker or fuse should be installed as close to the battery as possible.
- (3) Do not splice battery cables. If splicing is necessary, the most durable splice joint will be bare metal barrel crimped, flow-soldered and covered with adhesive lined heat shrink tubing. Strip the wire ends making sure that individual conductor strands are not damaged. Use only rosin core solder, proper crimping tools, and wire with a gauge at least equivalent to the circuit being lengthened. Do not use electrical tape.
- (4) Battery cable terminals will be bare metal barrel crimped or flow-soldered and covered with adhesive lined heat shrink tubing.
- (5) Use wire connectors with locking features such as positive locking, inertia locking, bolt together, and soft mold-over with locking external retainers.

## GENERAL

- (1) All frame contact areas must be wire brushed to bare metal, free of paint, dirt, and grease. Frame connections must be made using hardened flat washers under the bolt head and lock nuts. Corrosion preventive grease or compound is to be applied to the terminal area of the frame connection.
- (2) Frame cross members are not recommended as part of the ground return.
- (3) All circuit breakers and fuses should be located in one easily serviceable location with a means provided for identification of circuit function and current rating. Do not put circuit breakers or fuses in the vehicle cab.
- (4) Before welding to the chassis disconnect the battery. Also disconnect the power train, engine, valve, and transmission control modules.
- (5) Do not alter vehicle ignition, starting, and / or charging systems. Do not reroute engine compartment wiring.
- (6) Full copper circuitry and standardized polarity grounds are recommended.
- (7) Never increase the rating of a factory installed fuse or circuit breaker.
- (8) Disconnect the battery negative (ground) wire prior to any vehicle modification.

Following the above guidelines will provide you with years of trouble free service. Failing to incorporate the above guidelines will result in a voided warranty. Non-compliance with the guidelines above may result in a failure of electrical components, shutdown of engines, loss of backup brake systems, and the possibility of fire.