

G² dual drive® and Original Series Pickup Lift Mounting Instructions

Fullsize Chevy & GMC Trucks: 1988-1998 (Includes 1999-2000 "Classic") — **T-150**
 Toyota Tundra: 2000-2006 — **T-150-T**
 Toyota T-100: 1993-1999 — **T-150-T**

T-150 T-150-T

Preparing the Gate

1. Remove the mounting hardware which is banded to the liftgate.
2. Verify mounting bracket kit (Figures 1 and 2 and Tables 1 and 2).

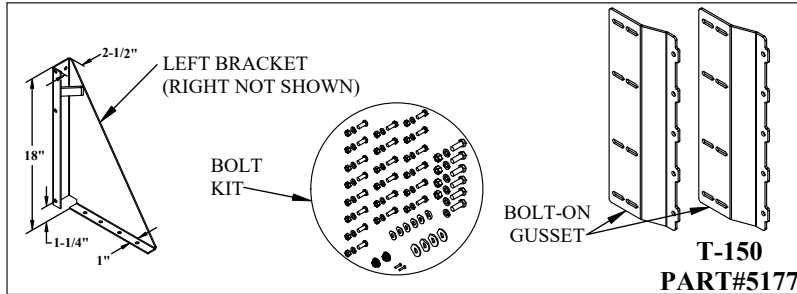

Figure 1: T-150 Part Identification.

Table 1: T-150 Parts List.

QTY.	PART NO.	DESCRIPTION
1	9094	Standard Pickup Bracket Bolt Bag Kit
1	5001	T-150 Left Corner Bracket
1	5002	T-150 Right Corner Bracket
2	6343	Standard Bolt-on Gusset

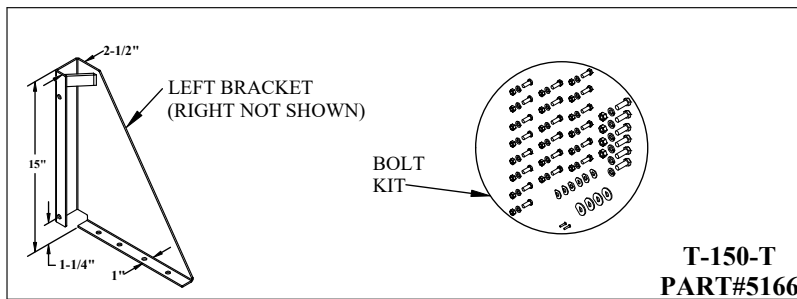

Figure 2: T-150-T Part Identification.

Table 2: T-150-T Parts List.

QTY.	PART NO.	DESCRIPTION
1	9094	Standard Pickup Bracket Bolt Bag Kit
1	5168	T-150-T Left Corner Bracket
1	5167	T-150-T Right Corner Bracket

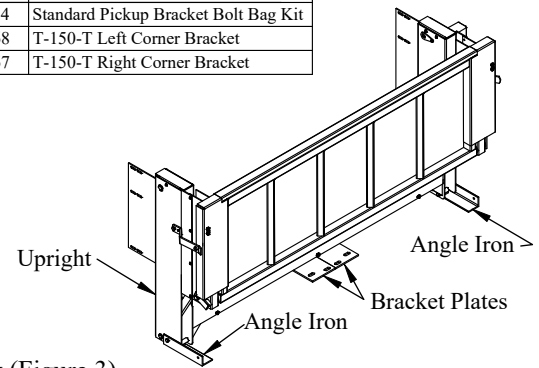

Figure 3: Complete liftgate (G² shown).

3. Support the liftgate; it will not stand upright without the angle irons - **G²** only.
4. Unbolt and Save the two (2) angle irons attached to the liftgate uprights - **G²** only (Figure 3).
5. Remove and Save the two (2) bracket plates attached to the liftgate - **G²** only (Figure 3).

Installing the Bolt-on Gussets (if supplied)

1. Install the eight (8) 3/8" x 1" button head bolts, lock washers, and nuts in the position shown for your configuration (Figure 4).
 - Original Series bolt-on gussets and button head bolts go to the inside of the 1/4" x 1" strip.
 - **G²** dual drive® bolt-on gussets and button head bolts go to the outside of the 1/4" x 1" strip.

Note: The extra hole in the bolt-on gusset is always below the 1/4" x 1" strip (Figure 5).

Note: If gussets are already welded to the uprights, you do not need the bolt-on gussets.

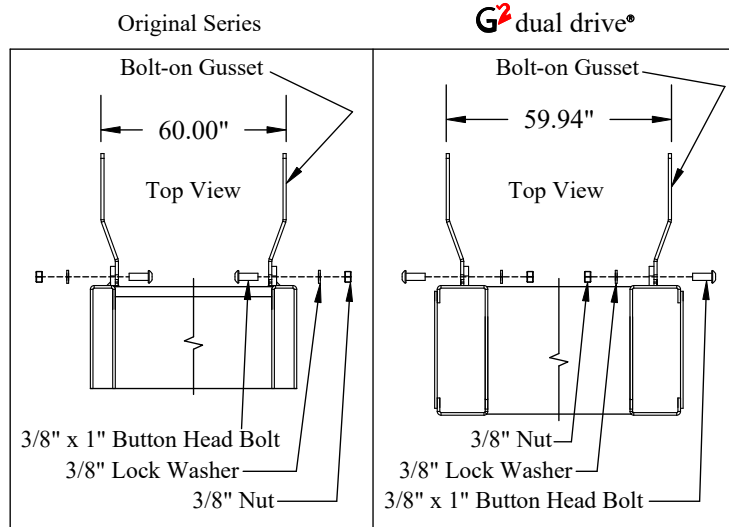

Figure 4: Top view of liftgate bolt-on gussets.

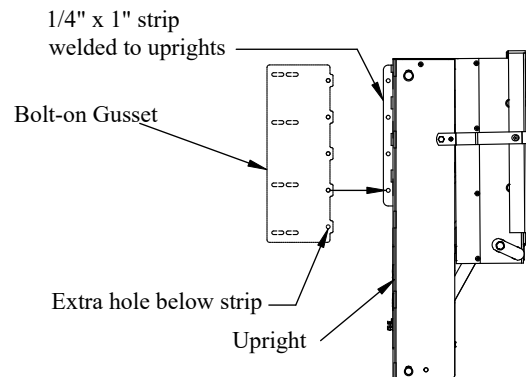

Figure 5: Liftgate requiring bolt-on gussets (G² shown).

Preparing the Truck

1. **Remove** the tailgate and tailgate hardware (Figure 6).
On Toyota Tundra approximately 3/8" needs to be cut off each tailgate hinge.
2. **Support** the rear bumper and hitch to keep them from falling while removing the mounting bolts.
3. **Remove** the hitch on Toyota Tundra only.
4. **Remove** the rear bumper and bumper mounting brackets.

Note: The tailgate, tailgate hardware, hitch (if removed), and rear bumper cannot be remounted after the liftgate is installed.

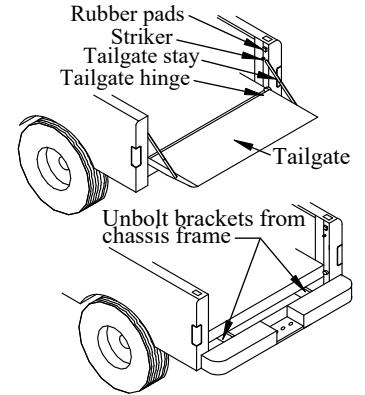

Figure 6: Remove Hardware.

Modifying the Tail Light Mounting

Note: This modification must be completed before the liftgate is installed so that the tail light bulbs can be replaced without removing the liftgate.

1. **Remove** the two (2) factory tail light screws from each tail light lens (Figure 7).
The screws will not be reused after the modification.
2. Carefully **Drill** a 9/64" hole through each tail light lens and internal sheet metal (Figure 7).
3. Carefully **Drill** a 3/16" hole through each tail light lens only, for screw clearance (Figure 7).

Note: Do not install the tail lights now if **G²** 1500 lb application.

4. **Apply** clear silicone sealant to the 3/16" holes in the tail light lenses and stainless self-tapping screws.
5. **Install** a stainless self-tapping screw, supplied, into each 9/64" hole to hold the tail light lenses in place (Do not over-tighten).

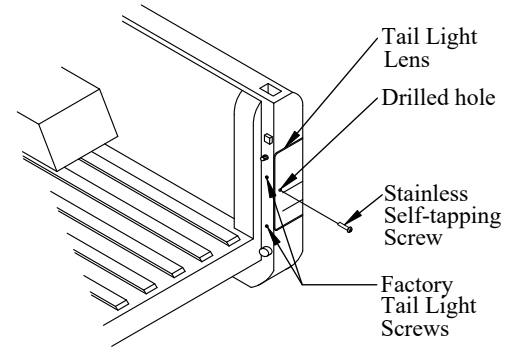

Figure 7: Tail light modification detail.

Installing the Filler Strip (Original Series Only)

Note: The filler strip must be mounted on the liftgate before the liftgate is mounted on the truck.
 Note: The filler strip will fill the gap between the liftgate and the truck bed.

- 1. Weld** the supplied filler strip (12ga.x1-1/4"x58-1/2") to the top corner of the liftgate mainframe (Figure 8).

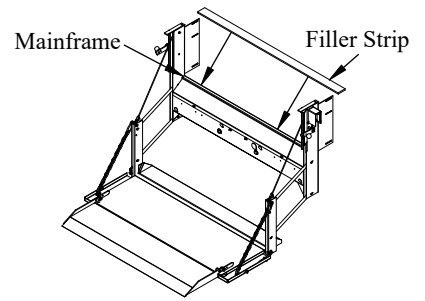

Figure 8: Filler strip location (Original Series).

Installing the Liftgate

- 1. Position** the mounting brackets into the truck bed in front of the corner posts (Figure 9).
Do not drill holes for mounting brackets at this time.

- 2. Position** the Tommy Lift into the bed opening. The liftgate should be:
 - Aligned with spare tire tube.
 - Centered in the opening.
 - Flush with the truck bed floor.
 - In a vertical position (level with the ground).

- 3. Hand tighten** each mounting bracket to the liftgate gussets using the supplied:
 - (3) 3/8"x1" hex head bolts on the bracket-side (Figure 9).
 - (3) 3/8" lock washers, and (3) 3/8" nuts on the gusset-side (Figure 9).

- 4. Allow** the liftgate to hang, supported by the corner posts.

- 5. Hold** the bracket against the corner post.

- 6. Check** for obstructions before drilling in the next step.

- 7. Drill** two (2) 3/8" holes into the truck bed floor using two holes in the bracket as a guide.
Choose two of the four holes provided with no obstructions on the underside (Figure 10).

- 8. Fasten** each bracket to the truck box using the supplied:
 - (2) 3/8"x1" hex head bolts on the top-side (Figure 10).
 - (2) washers, (2) lock washers, and (2) hex nuts on the under-side (Figure 10).

- 9. Adjust** the liftgate so the platform is level from front to back.
Check the clearance between the truck tail light lenses and the liftgate.

- 10. Tighten** the bolts securing the liftgate gusset to the mounting brackets.
The lock washer split must not be in the gusset slot when tightening bolts.

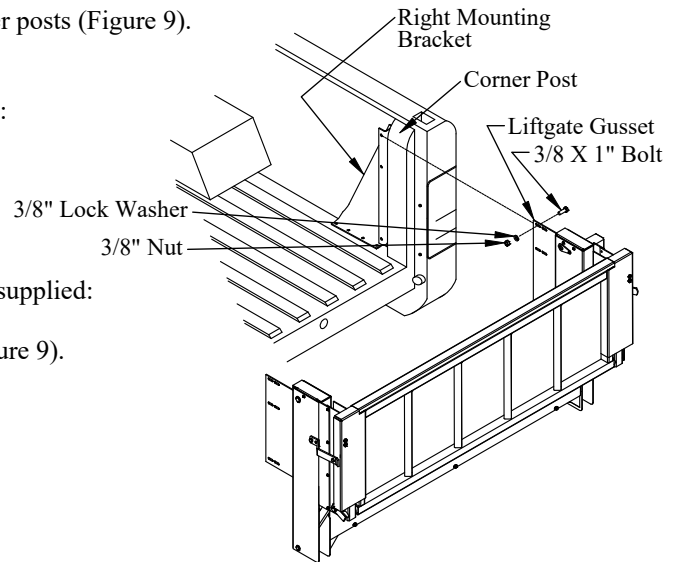

Figure 9: Mounting bracket and liftgate.

Note: Liftgate not shown for clarity.

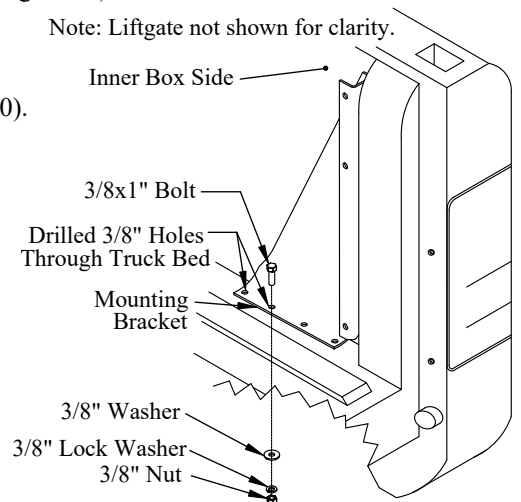

Figure 10: Mounting bracket and backer plate.

Adding Additional Support (G² 1500 lb Application Only)

Note: Additional bracket support is required at this capacity.

1. **Locate** the existing 3/8" hole in the mounting bracket (Figure 11).
2. **Check** for obstructions before drilling in the next step.
3. **Drill** a 3/8" hole in the truck corner post, using the bracket's hole as a guide.
4. **Fasten** the mounting bracket to the corner post using the supplied:
 - (1) 3/8"x1" hex head bolt on the bracket-side (Figure 11).
 - (1) 3/8" flat washer, (1) 3/8" lock washer, and (1) 3/8" nut on the truck-side (Figure 11).
5. **Repeat** for the other mounting bracket.
6. **Install** tail light lenses.

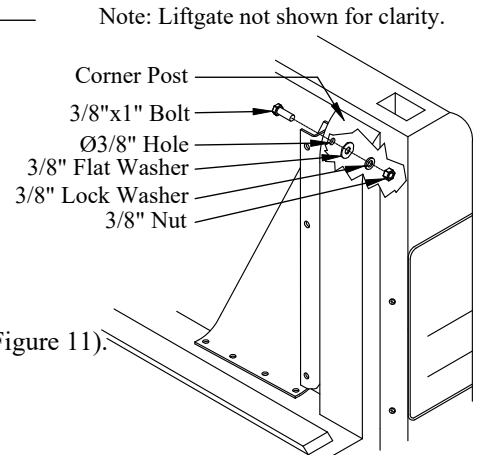

Figure 11: Additional support location.

Checking the Spare Tire Access (Chevy & GMC Trucks only)

Note: There are holes in the mainframe that provide access to the spare tire crank mechanism.

1. **Remove** the box cover by removing the 5/16" hex head nuts or bolts (Figure 12).
2. **Remove and Discard** the black plastic plug(s) from the mainframe at the dimensions shown (Figure 13).
3. **Verify** spare tire access operation by inserting the spare tire crank rod through the access hole(s).

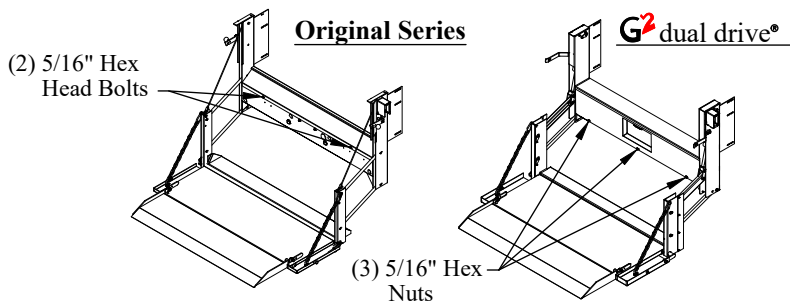

Figure 12: Box cover locations.

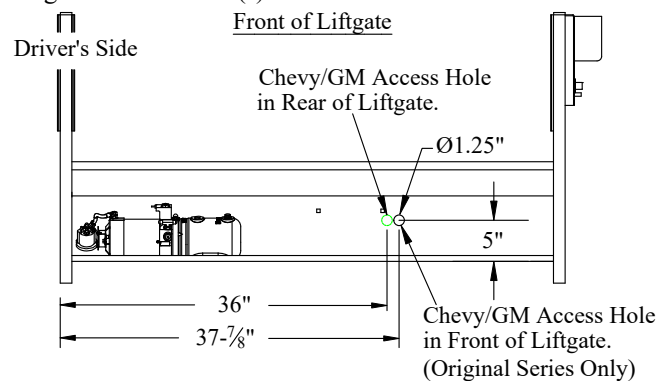

Figure 13: Spare tire access location for Chevy & GMC trucks.

Checking the Spare Tire Access (Toyota Trucks only)

Note: There are holes in the mainframe that provide access to the spare tire crank mechanism.

1. **Remove** the box cover by removing the 5/16" hex head nuts or bolts (Figure 12).
2. **Remove and Discard** the black plastic plug(s) from the mainframe at the location shown (Figure 14).
3. **Verify** spare tire access operation by inserting the spare tire crank rod through the access hole(s).

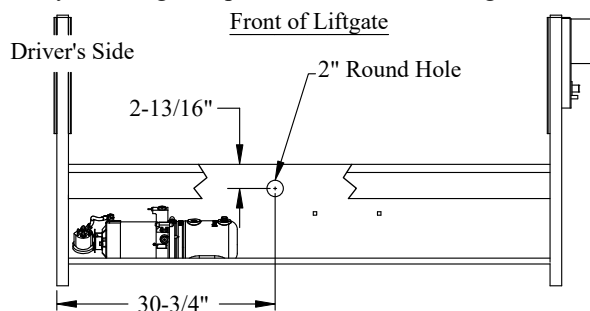

Figure 14: Spare tire access location for Toyota trucks.

Preparing the Gate for Wiring

1. **Unscrew** the solid plastic plug from the pump reservoir. The box cover should already be off.

Note: The hydraulic system has already been filled with the proper amount of hydraulic oil so **do not** add any oil at this time.

2. **Attach** 12 volts from a battery to the liftgate power cables (no battery chargers).

3. **Push** the hidden "Power On" switch (Figure 16). The amber "Power On" LED will illuminate.

4. **Push** the hidden "Liftgate Activated" switch twice within one second. The red "Liftgate Activated" LED will illuminate.

Note: With both lights on, the liftgate can be raised or lowered. If not used for 90 seconds, the control will automatically shut off.

5. **Push** the toggle switch down to lower the liftgate to the ground.

6. **Remove** the following from inside the liftgate mainframe:

- Owner/Operator Manual
- License plate light(s)
- License plate light hardware
- (1) Vent plug
- (2) Latch balls with studs (Original Series only)
- (1) 150 Amp manual reset circuit breaker
- (4) Copper lugs
- (2) License plate nuts and screws
- (1) Padlock with keys
- (5) 3/8" plastic plugs (G² only)
- (1) Drop away pin
- (1) Lower mounting kit

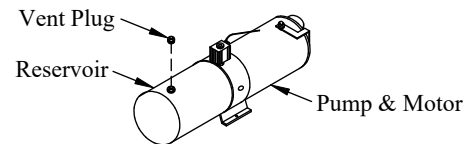

Figure 15: Vent plug.

7. **Install** the vent plug provided into the pump reservoir (Figure 15).

Routing the Power Cables

1. **Install** the circuit breaker on the vehicle fender, firewall, or other location inside the engine compartment away from moving parts. Leave enough room for the power cables to be installed and so that the circuit breaker can easily be reset.
2. **Loosen** the strain relief on the back of the liftgate mainframe.
3. **Pull** the power cable (coiled up in the liftgate mainframe) carefully through the strain relief. Leave approximately two (2) inches of slack inside the liftgate mainframe.
4. **Tighten** the strain relief.
5. **Route** the power cables along the frame to the battery following the *Tommy Gate Recommended Electrical Wiring Guidelines*.
6. **Pull** the excess cable beyond the battery.
7. **Separate** the positive(+) and negative(-) leads.
8. **Cut** the positive(+) lead to the length required to reach the auxilliary (AUX) terminal of the circuit breaker.
9. **Cut** the remaining pos.(+) lead long enough to reach from the circuit breaker battery (BAT) terminal to the pos.(+) battery terminal.
10. **Cut** the negative(-) lead to the length required to reach the negative battery terminal.

IMPORTANT: The pump and motor unit for this lift can require significant electrical power at 12 volts D.C. Be sure that the negative(-) ground lead is connected to the negative(-) terminal of the vehicle battery.

11. **Install** the copper lugs and heat shrink tubing on all required ends.
12. **Connect** the circuit breaker and battery as outlined in the *Tommy Gate Recommended Electrical Wiring Guidelines* and wiring diagram (Figure 16).

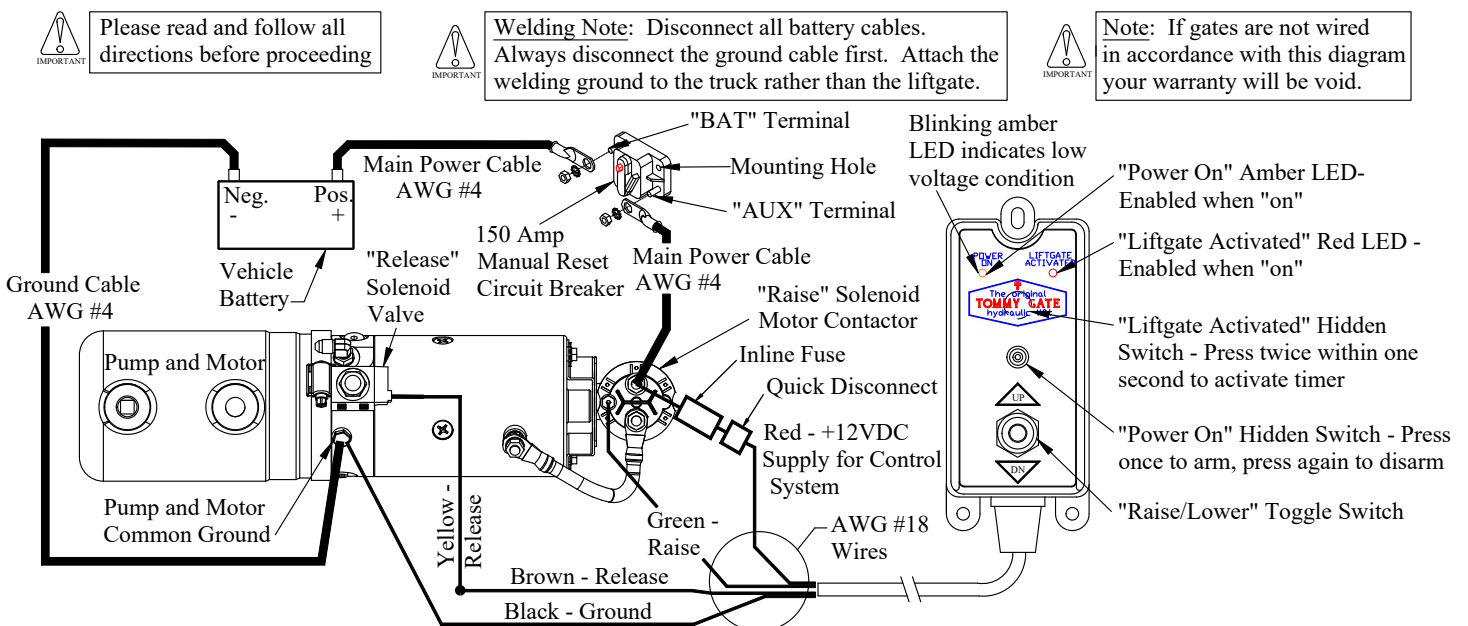

Ladder Logic/Wiring Diagram

Legend	
	Circuit Breaker
	Contactor - Normally Open Contacts
	Motor
	Solenoid/Contactor - Coil
	Battery Cable
	Wire
	Grounded through pump body.
	Eyelet Terminal
	Splice
	Quick Disconnect
	Fuse

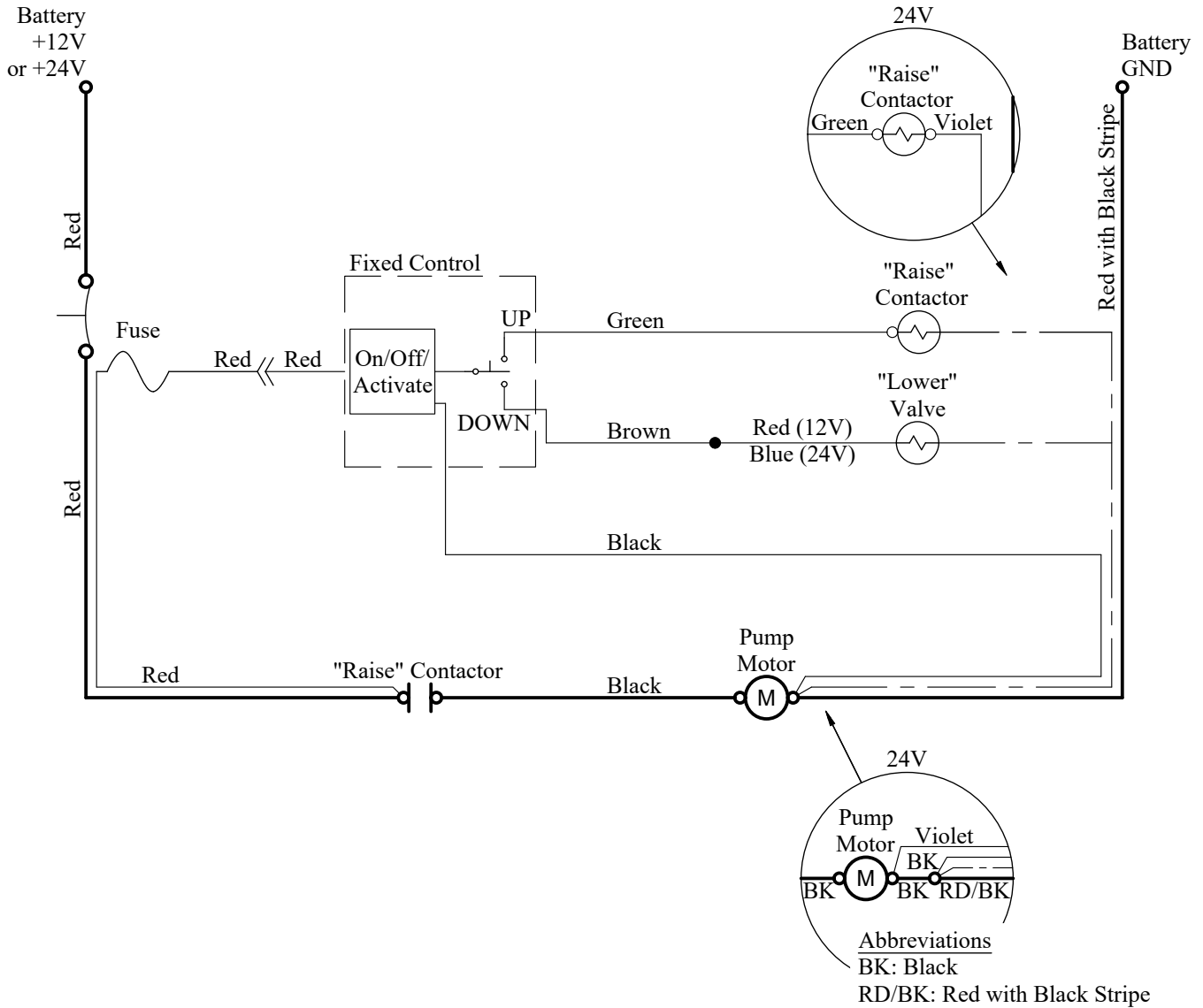

Installing the Lower Brace Irons (T-150-T only)

Note: If lower brace irons were not supplied with the liftgate, install the lower mount as shown below.

IMPORTANT: Do not install a liftgate without installing the lower brace irons or lower mount.

1. **Bolt** the two (2) brace irons to the bottom of the liftgate using 1/2" x 1-1/4" bolts, washers, and lock washers (Figure 17).

Note: Nuts have been welded to the inside of the liftgate to accept the bolts.

2. **Bolt** the lower brace irons to the truck frame using 1/2" x 1-1/4" bolts, washers, and lock washers. On some models, 1/2" holes may need to be drilled in the truck frame.

Note: The lower brace irons are of great importance because they add additional support to the liftgate.

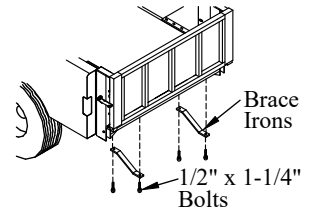

Figure 17: Lower brace iron location.

Installing the Lower Mount

IMPORTANT: Do not install a liftgate on a pickup without installing the lower mount.

1. **Install** the two (2) mounting angle irons to the bottom of the liftgate (Figure 18).
Select the holes in the liftgate that position the angle irons adjacent to the truck frame rails.

Note: Nuts have been welded to the inside of the liftgate to accept the bolts.

Note: If the liftgate already has a long angle iron, use it in place of the two mounting angle irons.

2. **Bolt** the bracket plates to the truck frame (Figure 19).
Modification to the bracket plates may be required.
3. **Clamp** the short angle irons to the bracket plates.
The short angle irons should extend out to the mounting angle irons on the liftgate.
4. **Tack weld** the bracket plates (see welding note at right), the short angle irons, and the mounting angle irons together.
5. **Remove** the tacked lower brackets from the truck.
6. **Weld** all seams with a heavy weld:
 - Where the bracket plates meet the short angle irons.
 - Where the short angle irons meet the mounting angle irons.
7. **Bolt** the completed brackets back to the truck frame and bottom of the liftgate.

Note: The lower mount is of great importance because it adds additional support to the liftgate.

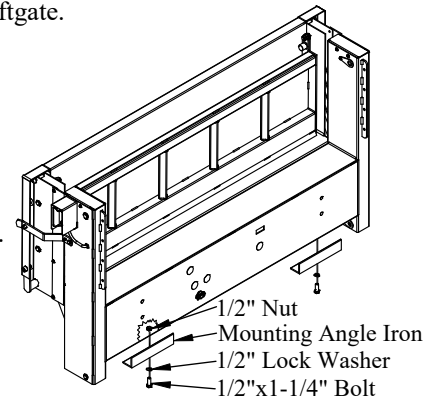

Figure 18: Mounting angle iron location.



WELDING NOTE!!! DISCONNECT ALL BATTERY CABLES. ALWAYS DISCONNECT THE GROUND CABLE FIRST. ATTACH THE WELDING GROUND TO THE TRUCK RATHER THAN THE LIFTGATE.

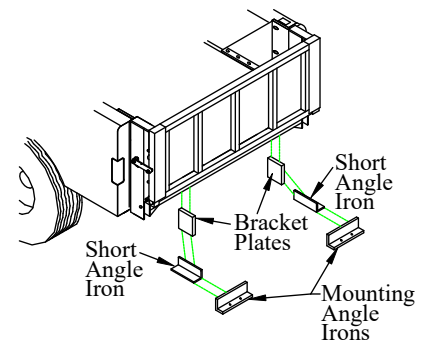

Figure 19: Lower bracket support.

Finishing the Liftgate Installation

1. **Install** the two (2) knobs on the platform latches (Original Series only) see (Figure 20).
2. **Install** the two (2) square plastic insert nuts for the license plate into the square holes on the liftgate.
3. **Install** the license plate using the two (2) stainless steel screws provided.
4. **Install** the license plate light(s) into the holes provided.
5. **Connect** the license plate light(s) to the vehicle's wiring following the *Tommy Gate Recommended Electrical Wiring Guidelines*.
The license plate light wire(s) can be run through the strain relief in the back of the liftgate.

Finishing the Liftgate Installation (continued)

Note: Additional wire may need to be spliced into the license plate light circuit to reach the connection point.
 Note: All electrical splices should be heat shrunk for corrosion protection.

6. **Install** the 3/8" round plastic plugs into the empty holes in the bottom of the uprights (G² only).
7. **See** the Owner's / Operator's Manual if drop away feature is desired.
8. **Install** the "Do's and Do Not's" decal in a highly visible area in the vehicle cab.
 This decal is with the Owner's / Operator's Manual.
9. **Reinstall** the spare tire, if previously removed.

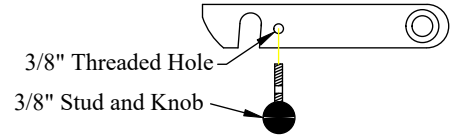

Figure 20: Original Series platform latch knob.

Testing the Operation of the Liftgate

CAUTION: Keep all foreign objects (body parts, tools, load weights, etc) out of the liftgate mainframe and away from pinch points at all times when operating the liftgate.

1. **Check** operation of the safety control for proper lift operation.
 Be sure the control shuts off automatically after 90 seconds of not being used.
2. **Raise** and **Lower** the unloaded platform on a flat surface looking for proper operating speed and alignment with the ground.
3. **Load** the platform with the rated capacity and **Measure** the time necessary to raise the platform.
 The platform should raise at roughly 2-3 inches per second.
4. **Examine** the platform for any downward creep.
5. **Time** the lowering operation with the platform still loaded.
 The load should descend at roughly 7-9 inches per second.
6. **Remove** the load from the platform and **Examine** the liftgate and vehicle for any problems such as hydraulic oil leaks, loose wiring, etc.
7. **Reinstall** the box cover.
8. **Close** and **Latch** the platform.
9. **Lock** the padlock through the hole in the platform or latch pin (Figure 21).
10. **Place** Owner's / Operator's Manual and padlock keys in the vehicle.

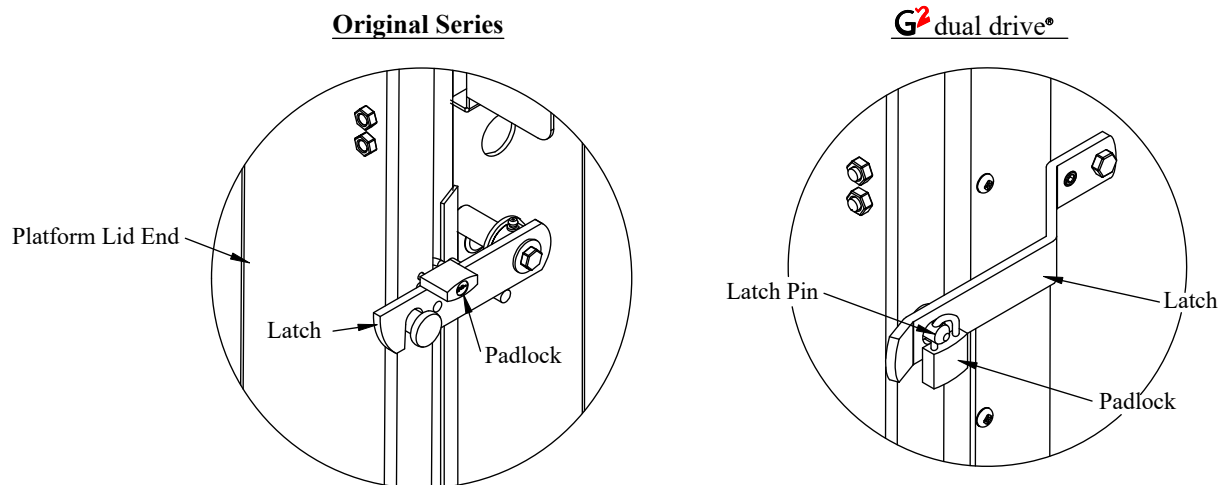

Figure 21: Padlock location.

Painting the Liftgate (if needed)

Your Tommy Gate has been primed with a gray polyurethane and painted with a black semi-gloss polyurethane topcoat to protect it from the environment. No additional paint is required unless shipping or installation damage or outdoor storage exposure has deteriorated the Tommy Gate paint. **Tommy Gate will not be responsible for shipping or installation damage or outdoor storage exposure that has marred or otherwise deteriorated the Tommy Gate paint.**

If you need to refinish the liftgate you should do the following:

1. **Remove** any dirt, oil, grease, salt, or other contamination by washing with a mild detergent solution.
2. **Rinse** thoroughly with fresh water and allow to dry.
3. Lightly **Scuff Sand** the Tommy Gate topcoat.
4. **Sand** and **Spot Prime** any area of the Tommy Gate paint that shows signs of damage or deterioration.
5. **Mask** off all safety decals, cylinder shafts and vents before painting.

WARNING: Paint overspray on the cylinder shaft(s) or vent(s) will damage the cylinder seals and void warranty.

6. After proper cleaning and surface preparation, **Apply** desired finish coat per paint manufacturer's recommendations.
7. **Remove** the masking from the safety decals and cylinders.
8. **Check** to ensure that all decals are clean and legible. Additional decals are available from the factory, if needed.

WIRE ROUTING

- (1) When routing wires, avoid heat (above 180°F), abrasion, vibration, metal edges, screws, and trim fasteners. If such routings are not possible, protective devices must be used. If wires must cross a metal edge, the edge should be covered with a protective shield and the wiring fastened within 3 inches on each side of the edge.
- (2) Grommets must be used where wires pass through holes in sheet metal, castings, and / or frame rails. Do not bend wires in a radius smaller than 10 times the wire diameter.
- (3) Routing wires into areas exposed to wheel wash should be avoided. If this cannot be avoided protective shields are required to protect the wires from stones, ice, salt and water damage. Provide a drip loop to prevent moisture from being conducted into switches, relays, circuit breakers, and fuses.
- (4) Wires should be supported every 18 inches with plastic zip ties or rubber-lined clips.
- (5) Wires must be routed to clear moving parts by at least 3 inches unless positively fastened or protected by a conduit. If wiring must be routed between two members where relative motion can occur, the wiring should be secured to each member, with enough wire slack to allow flexing without damage to the wire.
- (6) Maintain at least a 6 inch clearance from exhaust system components. If this is not possible, high temperature insulation and heat shields are required. Existing OEM heat shields, insulation, and wire shielding must be maintained.
- (7) Do not route or attach electrical wires to fuel lines. Route electrical wires at least 1-1/2 inches away from the engine.

BATTERY, WIRE, TERMINALS, AND CONNECTORS

- (1) Wire attachments at the battery must be protected from tension loads so there is no undue strain on the battery terminals. Wires should be routed down rather than horizontally from the terminals with no sharp bends adjacent to the connections.
- (2) Battery power for your Tommy Gate should come directly from the battery through the supplied circuit breaker or fuse. The circuit breaker or fuse should be installed as close to the battery as possible.
- (3) Do not splice battery cables. If splicing is necessary, the most durable splice joint will be bare metal barrel crimped, flow-soldered and covered with adhesive lined heat shrink tubing. Strip the wire ends making sure that individual conductor strands are not damaged. Use only rosin core solder, proper crimping tools, and wire with a gauge at least equivalent to the circuit being lengthened. Do not use electrical tape.
- (4) Battery cable terminals will be bare metal barrel crimped or flow-soldered and covered with adhesive lined heat shrink tubing.
- (5) Use wire connectors with locking features such as positive locking, inertia locking, bolt together, and soft mold-over with locking external retainers.

GENERAL

- (1) All frame contact areas must be wire brushed to bare metal, free of paint, dirt, and grease. Frame connections must be made using hardened flat washers under the bolt head and lock nuts. Corrosion preventive grease or compound is to be applied to the terminal area of the frame connection.
- (2) Frame cross members are not recommended as part of the ground return.
- (3) All circuit breakers and fuses should be located in one easily serviceable location with a means provided for identification of circuit function and current rating. Do not put circuit breakers or fuses in the vehicle cab.
- (4) Before welding to the chassis disconnect the battery. Also disconnect the power train, engine, valve, and transmission control modules.
- (5) Do not alter vehicle ignition, starting, and / or charging systems. Do not reroute engine compartment wiring.
- (6) Full copper circuitry and standardized polarity grounds are recommended.
- (7) Never increase the rating of a factory installed fuse or circuit breaker.
- (8) Disconnect the battery negative (ground) wire prior to any vehicle modification.

Following the above guidelines will provide you with years of trouble free service. Failing to incorporate the above guidelines will result in a voided warranty. Non-compliance with the guidelines above may result in a failure of electrical components, shutdown of engines, loss of backup brake systems, and the possibility of fire.