

# Cantilever Series Mounting Instructions

Nissan NV (AC)-  
2011-present

## Preparing the Gate

1. **Remove** the platform, mounting kit, and bridge assemblies, which are banded to the main assembly.  
Leave the banding that holds the folding cylinder to the main assembly.
2. **Verify** mounting kit, liftgate, and other components (Figure 1 and Table 1).

Table 1: Parts List.

QTY.	PART NO.	DESCRIPTION
1	10484	Main Assembly
1	10587	71" Split Platform Assembly
	11168	52" Split Platform Assembly
1	11189	Mounting Kit-Nissan (AC)
1	11098	Front Channel Assembly-Nissan
1	11193	Bridge Assembly - Nissan Right
1	11194	Bridge Assembly - Nissan Left
1	11190	Nissan Rear Cover
1	11094	Rear Channel Assembly-Nissan
1	10026	Upper Platform Cover
1	10298	Lower Platform Cover

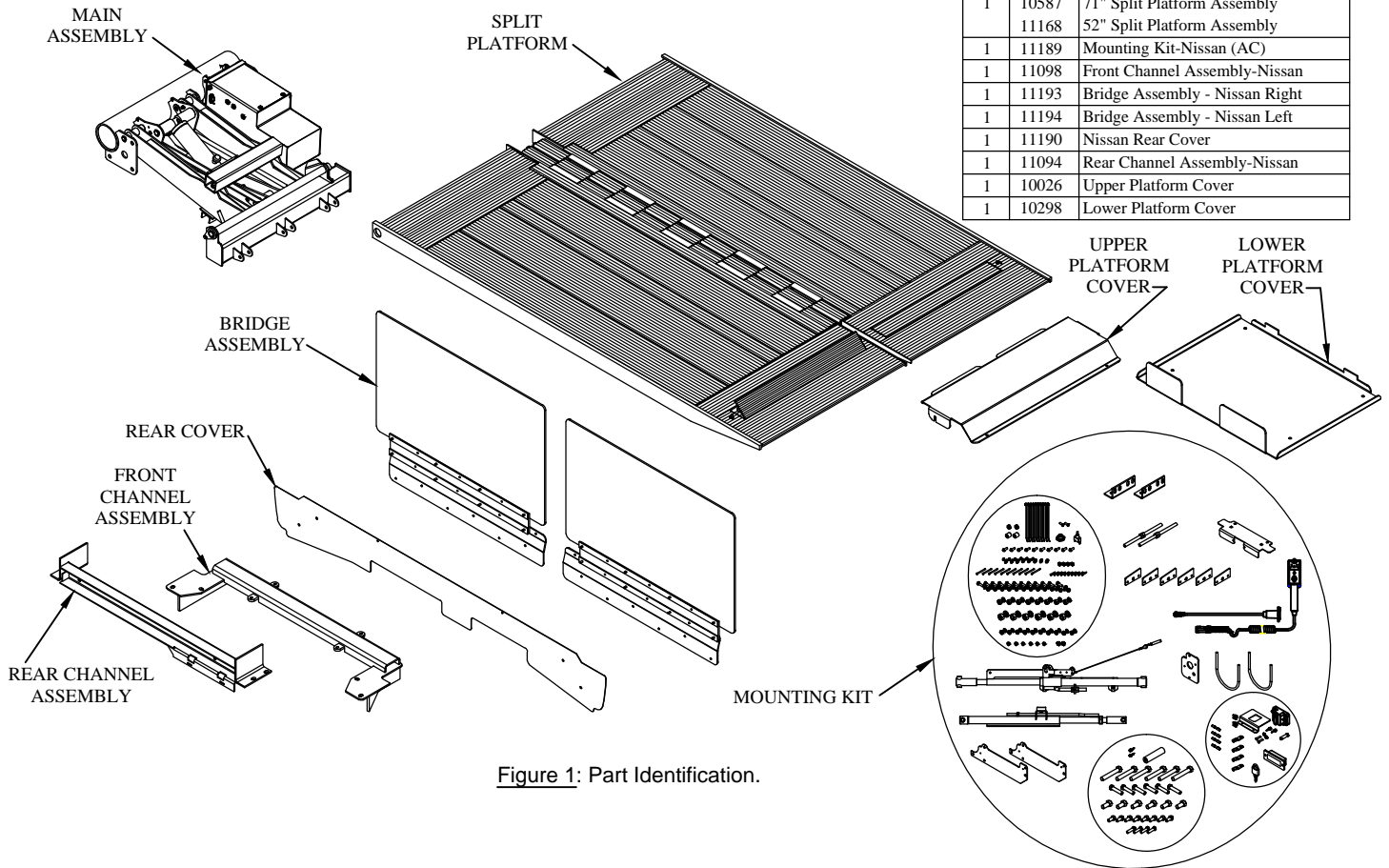

Figure 1: Part Identification.

3. **Remove** the pump box top cover by removing the three (3) screws, and verify that the vent plug is installed (Figure 2).
4. **Unscrew** the solid plastic plug from the pump reservoir and **Install** the vent plug provided, if not already installed (Figure 3).  
Note: The hydraulic system has already been filled with the proper amount of hydraulic oil so **do not** add any oil at this time.
5. **Install** the 5-link chain on the driver side bracket plate with a 3/8" x 1" bolt, flat washer, lock washer, and nut (Figure 4).  
Only the bolt head goes on the inside of the bracket plate.

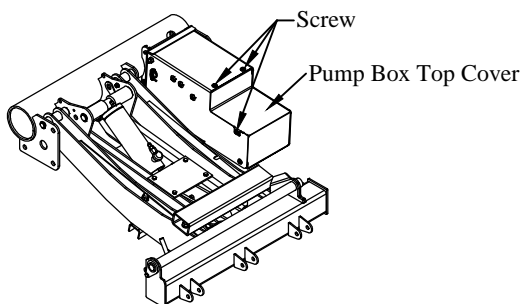

Figure 2: Pump box cover screws.

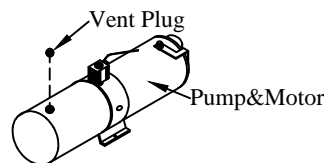

Figure 3: Vent plug installation.

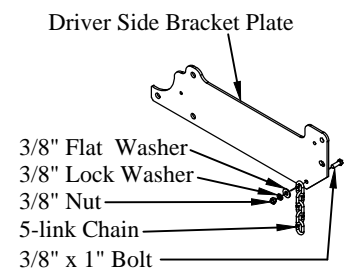

Figure 4: Chain-up feature hardware.

# Cantilever Series Mounting Instructions

## Preparing the Gate (continued)

- 6. Install** the fold up stop on the rod on the main assembly (Figure 5).
- 7. Install** the platform plates on the platform with the provided 5/16" x 1" bolts, lock washers, and nuts. The wide end goes toward the platform hinge. Note the location of the two (2) flat washers in place of lock washers (Figure 6).
- 8. Install** the bracket plates on the main assembly using six (6) 5/8" x 1-1/4" bolts, lock washers, and nuts. The bolt head and lock washer should be on the outside (Figure 7).
- 9. Install** rear mounting angles with four (4) 1/2" x 1-1/4" bolts on the inside and four (4) lock washers and nuts on the outside (do not tighten). Position the rear mounting angles in the lowest position (higher set of slots).

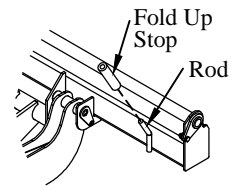

Figure 5: Platform stop location.

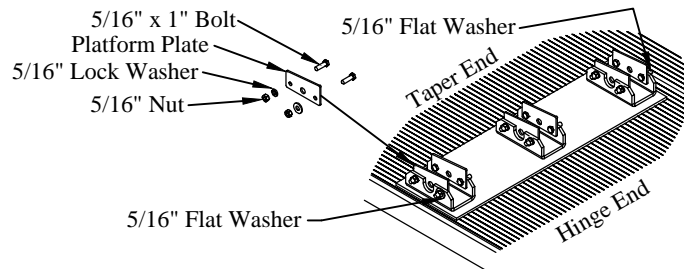

Figure 6: Platform plate location.

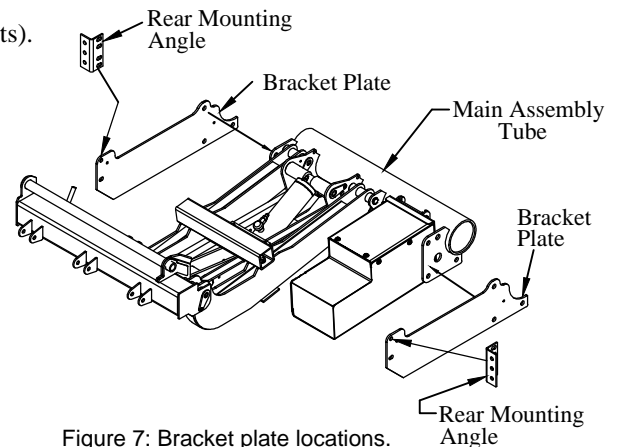

Figure 7: Bracket plate locations.

## Preparing the Van

- 1. Support** the rear bumper and hitch to keep them from falling while removing the mounting bolts.
- 2. Remove** the hitch, if equipped.
- 3. Remove** the rear bumper, if equipped.
- 4. Remove** the spare tire using the tools supplied with the vehicle. The spare tire will have to be stored in another location after gate installation.

Note: The hitch, rear bumper, and spare tire cannot be remounted after the liftgate is installed.

- 5. Replace** the factory body bolts with the supplied welded body bolts (Figure 8). Use the factory nuts/washers on the top-side (under the floor mat).
- 6. Install** the front channel assembly on the van frame (Figure 8). Use the two (2) installed welded body bolts with 1/2" flat washers, lock washers, and nuts on the under-side. Use two (2) supplied M12 bolts, flat washers, and lock washers.
- 7. Install** the rear channel assembly on the rear of the van frame (Figure 8). Use the four (4) supplied M12 bolts, flat washers, and lock washers.

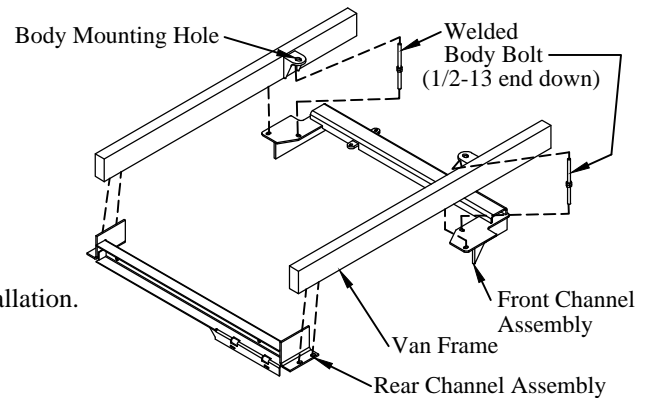

Figure 8: Rear channel assembly location.

# Cantilever Series Mounting Instructions

## Installing the Main Assembly

- 1. Securely Position** the main assembly onto a lifting device, pallet, or other structure so that it cannot tip or fall. It must be supported by the bracket plates, not the lift arms.
- 2. Position** the main assembly under the truck. Make sure there are no wires or hoses in a position where they may be pinched.
- 3. Raise** the main assembly into position below the van frame. Do not lift by the lift arms, otherwise the brackets may not reach.
- 4. Install** the 3/8" U-bolts around the main assembly tube.
- 5. Attach** the 3/8" U-bolts to the front channel assembly with the supplied four (4) flat washers, lock washers and nuts.
- 6. Attach** the rear mounting angles to the rear channel assembly with the supplied four (4) 1/2" x 1-1/4" bolts, lock washers, and nuts (Figure 9).
- 7. Remove** the lifting device, pallet, or other structure from the main assembly.
- 9. Tighten** all liftgate mounting bolts, bracket bolts, and U-bolts.
- 10. Install** the license plate bracket on the rear channel assembly (Figure 9). Use the two (2) supplied 1/4-20 flat head bolts and keps nuts.
- 11. Install** four (4) 3/8" bolts with spacers and hex nuts on the rear cover. The two (2) 0.25" spacers go on the lower two holes (Figure 10).
- 12. Install** the rear cover on the rear of the van (Figure 10). Use the supplied four (4) 3/8" flat washers, lock washers, and nuts.

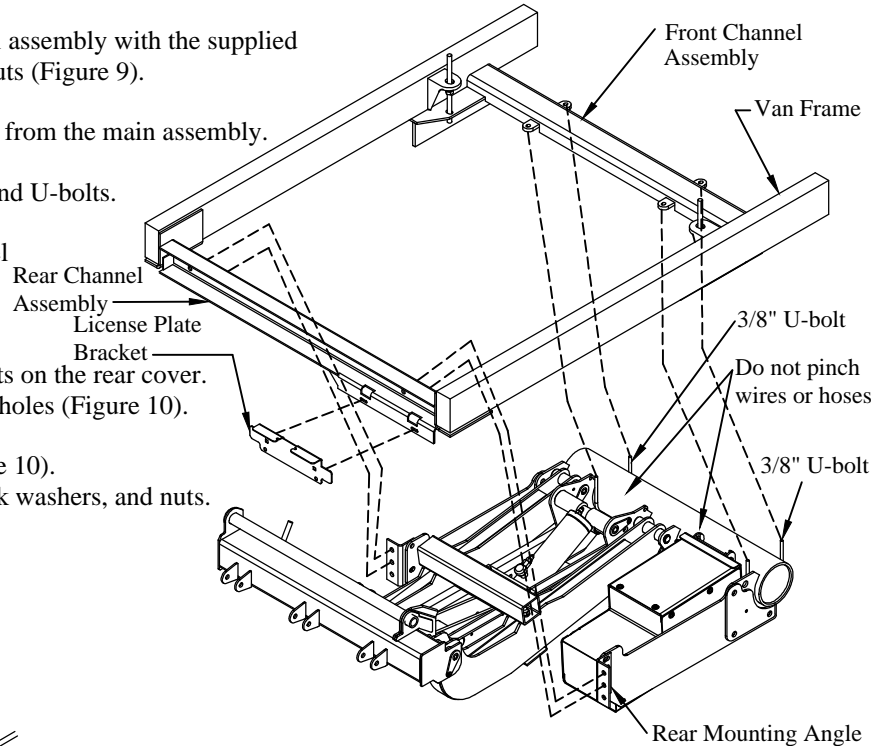

Figure 9: Main assembly position on frame.

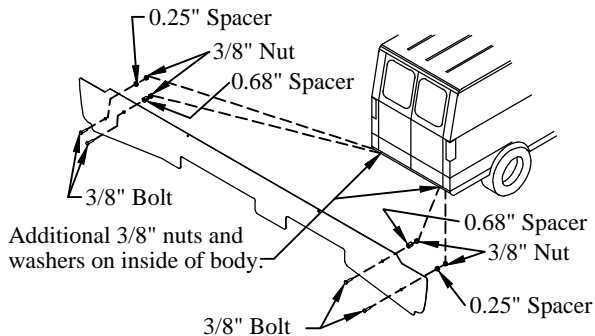

Figure 10: Rear cover hardware location.

# Cantilever Series Mounting Instructions

---

## Routing the Power Cables

---

Note: Any time a hole is drilled in the vehicle, apply rust preventative to the bare metal.

1. **Install** the circuit breaker near the battery, leaving enough room for the power cables and circuit breaker cover to be installed and so that the circuit breaker can easily be reset.
2. **Route** the power cables along the frame to the battery. Follow the *Tommy Gate Recommended Electrical Wiring Guidelines*. Provide at least 12" of extra cable near the pump box for later service.
3. **Pull** the excess cable beyond the battery.
4. **Separate** the positive(+) and negative(-) leads.
5. **Cut** the positive(+) lead to the length required to reach the auxiliary (AUX) terminal of the circuit breaker.
6. **Cut** the remaining pos.(+) lead long enough to reach from the circuit breaker battery (BAT) terminal to the pos.(+) battery terminal.
7. **Cut** the negative(-) lead to the length required to reach the negative battery terminal.

**IMPORTANT:** The pump and motor unit for this lift can require significant electrical power at 12 volts D.C.  
Be sure that the negative(-) ground lead is connected to the negative(-) terminal of the vehicle battery.

8. **Install** the copper lugs on all required ends.
  9. **Connect** the circuit breaker and battery as outlined in the *Tommy Gate Recommended Electrical Wiring Guidelines* and wiring diagram (Figure 14).
  10. **Check** for obstructions before using the self-drilling screws in the next step.
  11. **Install** the plastic circuit breaker cover over the circuit breaker using the supplied #12 self-drilling screws (Figure 11).
  12. **Push** the hidden "Power On" switch (Figure 14). The amber "Power On" LED will illuminate.
  13. **Push** the hidden "Liftgate Activated" switch twice within one second. The red "Liftgate Activated" LED will illuminate.
- Note: With both lights on, the liftgate can be raised or lowered. If not used for 90 seconds, the control will automatically shut off.

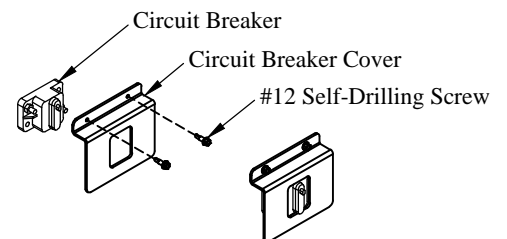

Figure 11: Circuit breaker cover.

# Cantilever Series Mounting Instructions

## Installing the Pendant Control

Note: Any time a hole is drilled in the vehicle, apply rust preventative to the bare metal.

Note: The driver side rear door cannot be opened unless the liftgate is partially lowered.

- 1. Locate** an existing hole in the passenger, rear door pillar to mount the toggle switch and pendant control female connector. Make sure there is enough depth inside the door pillar for the toggle switch and female connector. The pendant control female connector should face forward, not inward.
- 2. Check** for obstructions before drilling in the next step.
- 3. Drill** a 1-1/4" hole in the van floor near the rear door pillar where the mounting bracket will be located.
- 4. Connect** the control cable to the pump box via the amp connector (if it is not hard wired)
- 5. Disconnect** the wires from the female connector if needed to route the control cable in the next steps.
- 6. Route** the control cable from the pump box to the mounting bracket through the drilled 1-1/4" hole. Provide at least 12" of extra cable near the pump box for later service. Follow the *Tommy Gate Electrical Guidelines*.
- 7. Install** the female connector in the mounting bracket using the supplied two (2) 1/4-20 screws and keps nuts.
- 8. Reconnect** the female connector wires if previously disconnected (Figure 13).
- 9. Install** the fold/unfold toggle in the 1/2" hole in the mounting bracket.
- 10. Position** the mounting bracket over the hole in the door pillar (Figure 12).
- 11. Mark** the two (2) small holes to be drilled in the door pillar using the mounting bracket as a guide.
- 12. Check** for obstructions before drilling in the next step.
- 13. Drill** two (2) 13/64" holes in the locations previously marked.
- 14. Route** the two-conductor wire from the liftgate to the toggle switch through the drilled 1-1/4" hole in the van floor. Provide at least 12" of extra wire near the pump box for later service. Follow the *Tommy Gate Electrical Guidelines*.
- 15. Connect** the wires to the toggle switch (Figure 14).
- 16. Install** the supplied two (2) 1/4-20 self-tapping screws, through the mounting bracket, and into the door pillar.
- 17. Secure** any loose or excess wires to the main lift assembly away from moving parts.
- 18. Connect** the pendant control to the female connector.

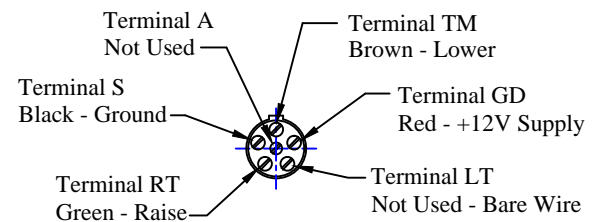
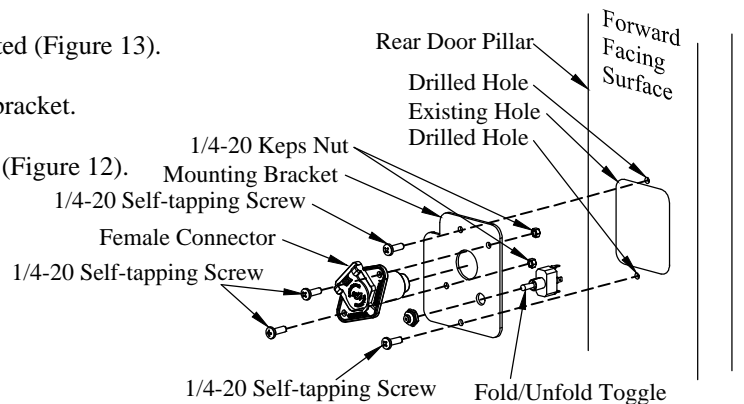

Note: This is a front (terminal end) view, not a rear (wire end) view.

Figure 13: Female connector wiring.

# Cantilever Series Mounting Instructions

**!!! PLEASE READ AND FOLLOW ALL DIRECTIONS BEFORE PROCEEDING !!!** **IMPORTANT** **NOTE !!! IF GATES ARE NOT WIRED IN ACCORDANCE WITH THIS DIAGRAM YOUR WARRANTY WILL BE VOID.** **IMPORTANT** **WELDING NOTE !!! DISCONNECT ALL BATTERY CABLES. ALWAYS DISCONNECT THE GROUND CABLE FIRST. ATTACH THE WELDING GROUND TO THE VEHICLE RATHER THAN THE LIFTGATE.**

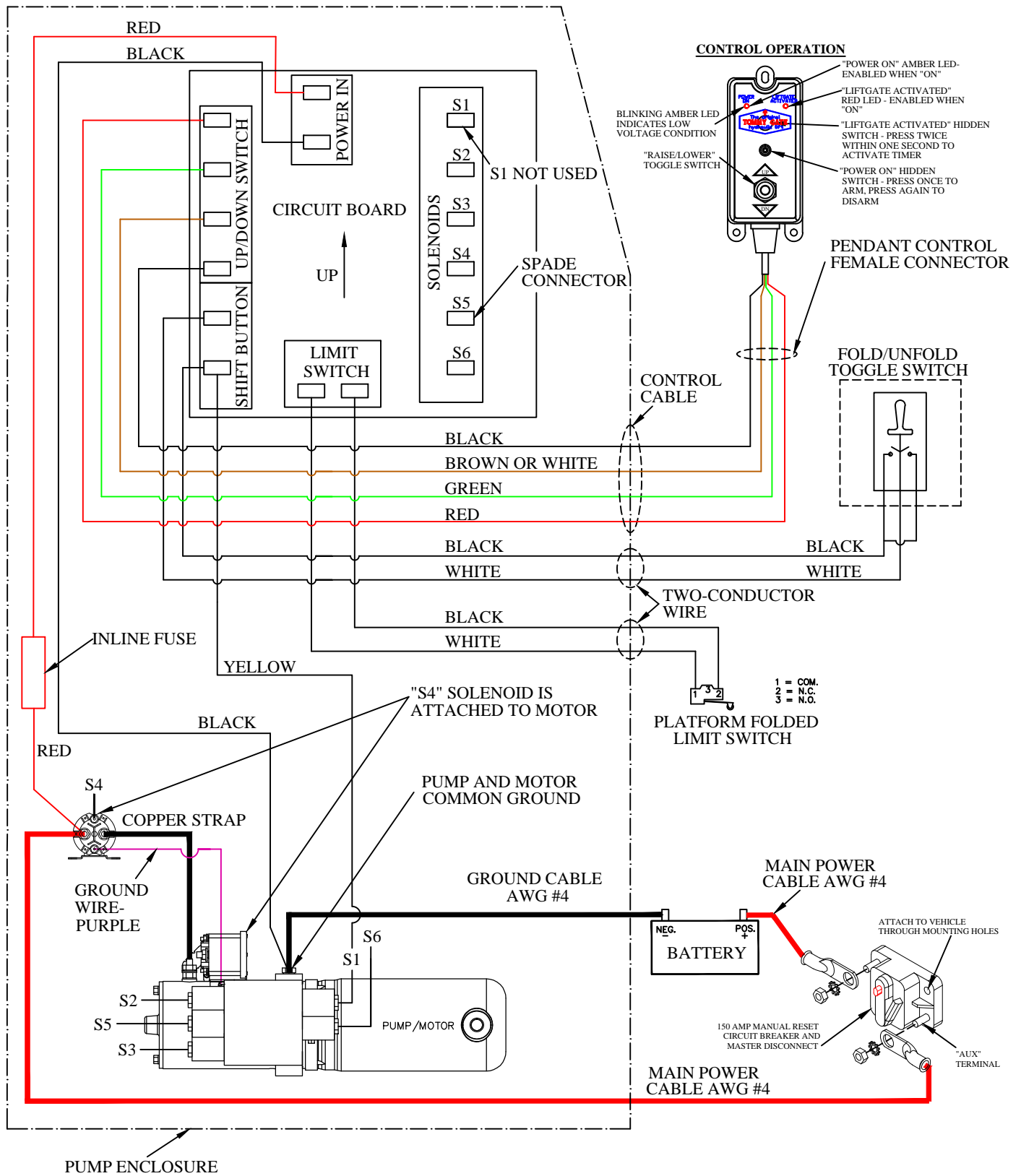
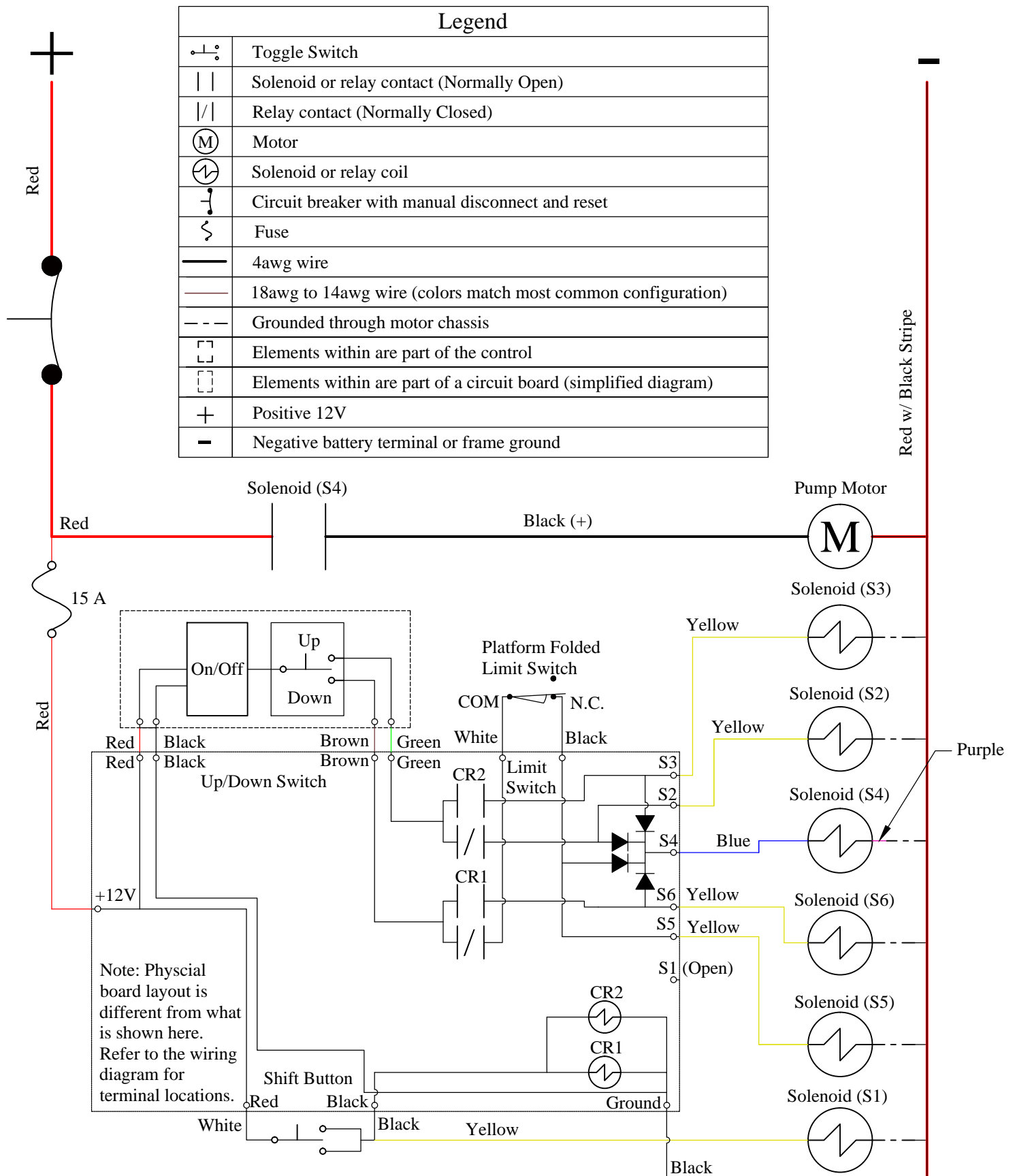

Figure 14: Wiring diagram.

# Cantilever Power Unit Ladder Logic



# Cantilever Series Mounting Instructions

## Installing the Platform

**CAUTION:** Keep all foreign objects (body parts, tools, load weights, etc) away from the liftgate main assembly and away from pinch points at all times when operating the liftgate.

- 1. Install** the support arms on the main assembly, using a 1/2"x3-3/4" GR 8 bolt and lock nut, do not tighten. The threaded end of the support arm goes toward the main assembly (Figure 15).
- 2. Install** the folding cylinder on the main assembly, using a 1/2"x3-3/4" GR 8 bolt and lock nut, do not tighten. The threaded end of the cylinder goes toward the main assembly (Figure 15).
- 3. Remove** the hinge tube from the main assembly. Save the 5/16" screw, lock washer, and nut, they will be reused.
- 4. Install** the limit switch bracket on the passenger side support arm with two (2) #12 self-threading screws. See Figure 14 for bracket shipping location. Make sure that the limit switch is not in the pushed position (Figure 16).
- 5. Position** the platform on the main assembly. The limit switch wire goes under the platform.
- 6. Support** the platform near the taper end to keep it from falling.
- 7. Insert** the hinge tube through the platform and main assembly from the driver side.
- 8. Install** the 5/16" screw, lock washer, and nut in the hinge tube keeper.

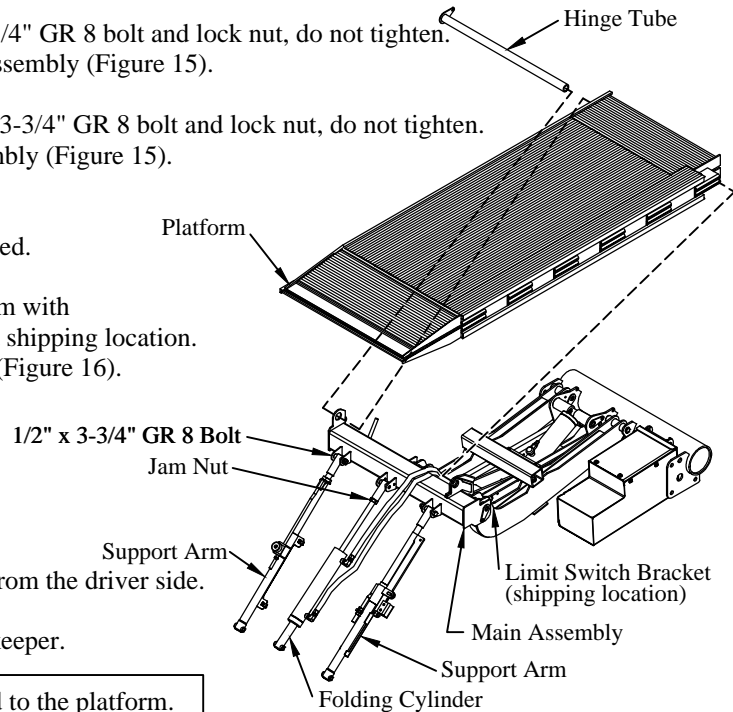

Figure 15: Platform parts location.

**CAUTION:** Do not operate the folding cylinder until it is bolted to the platform.

- 9. Raise or Lower** the lift until the folding cylinder can be bolted to the platform. The lift will lower only if the limit switch is not pushed.
- 10. Attach** the folding cylinder to the platform, using a 1/2" x 3-3/4" GR 8 bolt and lock nut, do not tighten.
- 11. Fold** the platform up partially, using the hydraulic fold function. Make sure the platform is folded in half before using the hydraulic fold function.
- 12. Attach** the support arms to the platform, using 1/2" x 3-3/4" GR 8 bolts and lock nuts, do not tighten.
- 13. Lower** the lift to the ground.

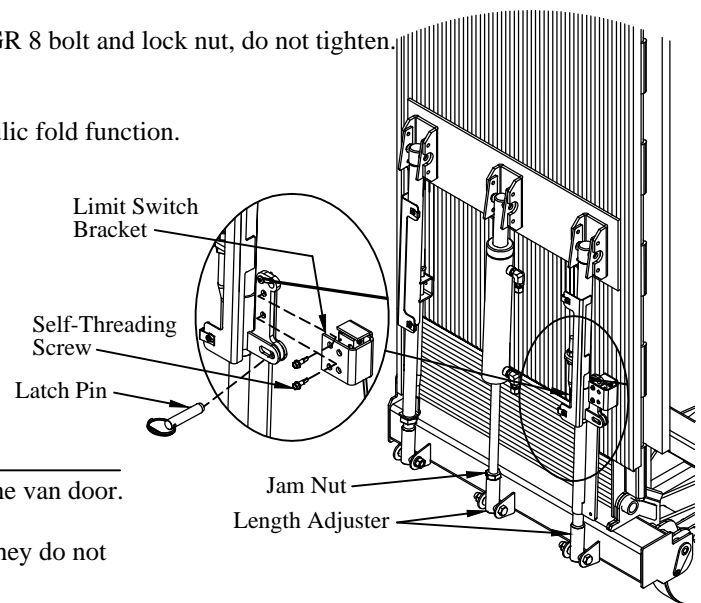

Figure 16: Platform latch and adjustment.

## Adjusting the Platform

- 1. Verify** that the platform folds to a vertical position without hitting the van door.
- 2. Loosen** the 3/8" nuts on the driver side support arm (Figure 18) so they do not contact the stop bracket when the platform is folded.
- 3. Support** the platform to keep it from falling or hitting the van in the next steps (Figure 16).
- 4. Adjust** the folding cylinder for closed/vertical position, if needed.
  - a. Loosen** the jam nut (cylinder only).
  - b. Remove** the 1/2" x 3-3/4" bolt and nut.
  - c. Rotate** the length adjuster: "in" to close less or "out" to close more.
  - d. Reinstall** the 1/2" x 3-3/4" bolt and nut.

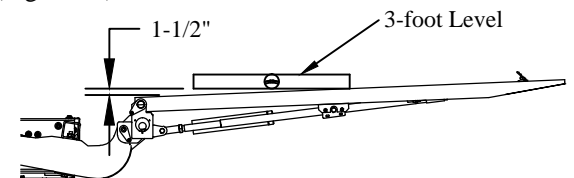

Figure 17: Platform position.

- 5. Unfold** the platform completely.



# Cantilever Series Mounting Instructions

## Adjusting the Platform (continued)

6. **Adjust** the passenger side support arm so that the platform is 1-1/2" from level over a 3-foot length (Figure 17). Adjustment similar to folding cylinder.
7. **Adjust** the driver side support arm so that both support arms carry the platform load equally. Adjustment similar to folding cylinder.
8. **Fold** the platform to the vertical position.
9. **Tighten** the lower 3/8" nut on the driver side support arm until it contacts the stop bracket (Figure 18).
10. **Unfold** the platform partially.
11. **Tighten** the lower 3/8" nut on the driver side support arm an additional half turn.
12. **Tighten** the second 3/8" nut on the driver side support arm against the lower 3/8" nut.
13. **Loosen** the adjustment nuts on the passenger side support arm (Figure 18).
14. **Fold** the platform to the vertical position.
15. **Align** the latch slots/holes on the passenger side support arm.
16. **Insert** the latch pin into the aligned slots/holes on the passenger side support arm.
17. **Tighten** the adjustment nuts on the passenger side support arm.
18. **Verify** that all bolts have been re-installed and the cylinder jam nut is tight.

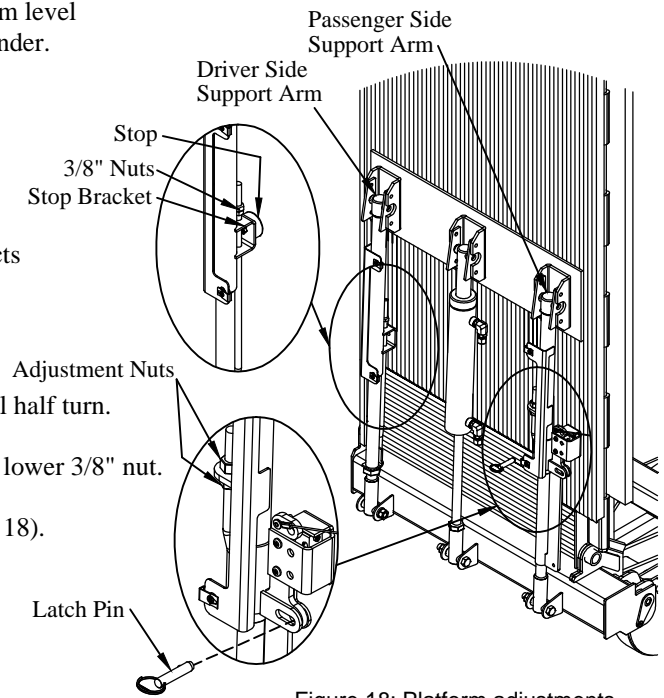
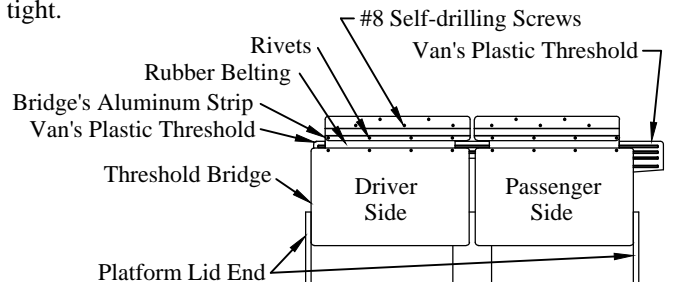

Figure 18: Platform adjustments.

## Installing the Threshold Bridge

1. **Lower** the platform until the rear doors can be opened.
2. **Open** the rear doors of the van.
3. **Raise** the platform to the top of its travel.
4. **Position** the driver side threshold bridge across the threshold (Figure 19).  
Align the aluminum strip on the bridge with the van's plastic threshold.  
Align the left side of the bridge with the inside of the platform lid end.
5. **Pre-Drill** partially through thick floors (not sheet metal) with 3/16" drill bit to aid self-drilling screws in next step.  
Do not drill through the sheet metal floor.
6. **Attach** the driver side threshold bridge to the van floor using the supplied five (5) #8 x 1-1/4" or 2" self-drilling screws.
7. **Position** the passenger side threshold bridge across the threshold (Figure 19).  
Align the aluminum strip on the bridge with the van's plastic threshold.  
Align the right side of the bridge with the inside of the platform lid end.  
The threshold bridges will not be centered in the van opening.
8. **Pre-Drill** partially through thick floors (not sheet metal) with 3/16" drill bit to aid self-drilling screws in next step.  
Do not drill through the sheet metal floor.
9. **Attach** the passenger threshold bridge to the van floor using the supplied five (5) #8 x 1-1/4" or 2" self-drilling screws.



Note: threshold bridges are not centered in van.

Figure 19: Threshold bridge location.

# Cantilever Series Mounting Instructions

## Finishing the Liftgate Installation

1. **Install** the two (2) square plastic insert nuts into the square holes on the license plate assembly.
2. **Install** the license plate using the two (2) 1/4-20 self-tapping screws provided.
3. **Install** the license plate light into the holes provided.
4. **Connect** the license plate light to the vehicle's wiring following the *Tommy Gate Recommended Electrical Wiring Guidelines*.

Note: Additional wire may need to be spliced into the license plate light circuit to reach the connection point.

Note: All electrical splices should be heat shrunk for corrosion protection.

5. **Install** the "Do's and Do Not's" decal in a highly visible area in the vehicle cab. This decal is with the Owner's / Operator's Manual.
6. **Pull** any excess fold cylinder hose toward the underside of the van. Do this with the platform in the raised and stored position. Make sure the hose will not get pulled, pinched, or kinked during operation.
7. **Install** the upper aluminum cover on the lower 5/16" support arm bolts. 5/16" flat washers should have been installed previously (Figure 20).
8. **Drill** two (2) 13/64" holes in the platform, using the holes in the aluminum cover as a guide.
9. **Install** two (2) 1/4-20 self-tapping screws in the drilled holes.
10. **Install** the lower aluminum cover using four (4) 1/4-20 self-tapping screws.
11. **Verify** that all mounting bolts and nuts have been installed and tightened.
12. **Secure** the limit switch wire to the support arm and limit switch bracket using two (2) plastic zip ties. This should be done with the platform unfolded.
13. **Adhere** decal (PN 10476) to the exterior bottom right corner of the driver side rear door (Figure 21).
14. **Apply** sealant to the 1-1/4" hole that was drilled in the van floor.

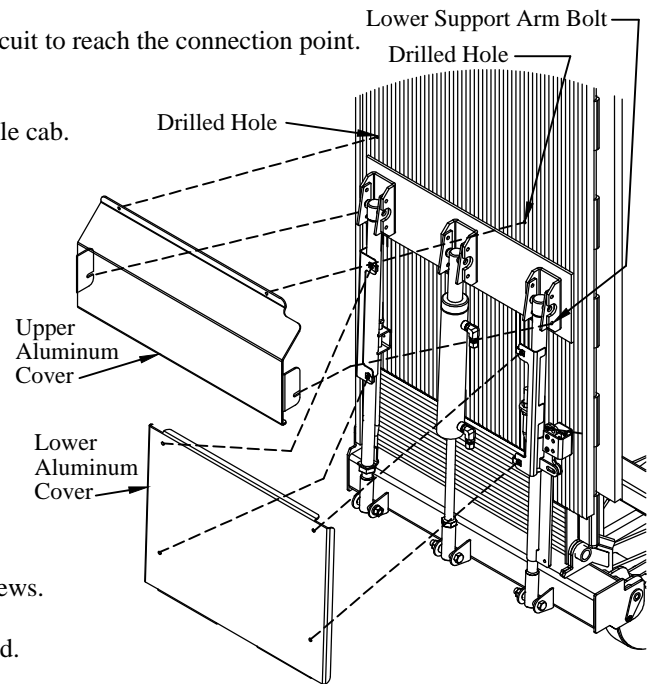

Figure 20: Aluminum cover installation.

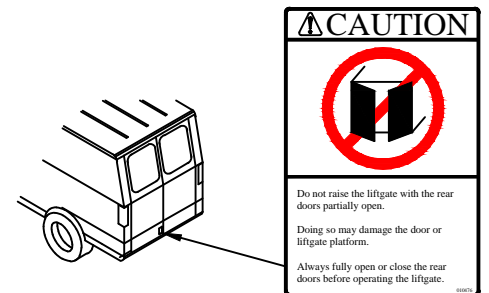

Figure 21: Caution decal location.

# Cantilever Series Mounting Instructions

## Testing the Operation of the Liftgate

**CAUTION:** Keep all foreign objects (body parts, tools, load weights, etc) away from the liftgate main assembly and away from pinch points at all times when operating the liftgate.

1. **Check** operation of the safety control for proper lift operation.  
Be sure the control shuts off automatically after 90 seconds of not being used.
2. **Raise** and **Lower** the unloaded platform on a flat surface looking for proper operating speed and alignment with the ground.  
The lift should not lower until the gate is partially unfolded.
3. **Load** the platform with the rated capacity and **Measure** the time necessary to raise the platform.  
The platform should be fully raised within 15 seconds.
4. **Examine** the platform for any downward creep.
5. **Time** the lowering operation with the platform still loaded. The platform should be fully lowered and tilted within 10 seconds.
6. **Remove** the load from the platform and  
**Examine** the liftgate and vehicle for any problems such as hydraulic oil leaks, loose wiring, etc.
7. **Reinstall** the pump cover.
8. **Fold** the platform in half.
9. **Raise** and **Fold** the platform using the hydraulic fold function.
10. **Insert** the latch pin into the storage hole (Figure 22).
11. **Insert** the locking pin through the hole in the passenger side support arm (Figure 22).
12. **Lock** the padlock through the hole in the locking pin (Figure 22).
13. **Place** Owner's / Operator's Manual and padlock keys in the vehicle.

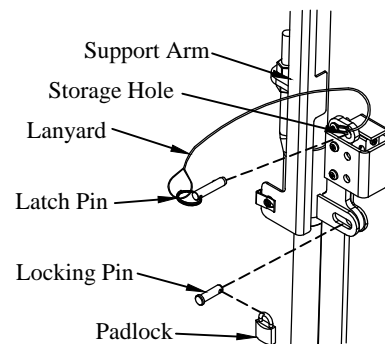

Figure 22: Platform lock.

## Painting the Liftgate (if needed)

Your Tommy Gate has been primed with a gray polyurethane and painted with a black semi-gloss polyurethane topcoat to protect it from the environment. No additional paint is required unless shipping or installation damage or outdoor storage exposure has deteriorated the Tommy Gate paint. **Tommy Gate will not be responsible for shipping or installation damage or outdoor storage exposure that has marred or otherwise deteriorated the Tommy Gate paint.**

If you need to refinish the liftgate you should do the following:

1. **Remove** any dirt, oil, grease, salt, or other contamination by washing with a mild detergent solution.
2. **Rinse** thoroughly with fresh water and allow to dry.
3. Lightly **Scuff Sand** the Tommy Gate topcoat.
4. **Sand** and **Spot Prime** any area of the Tommy Gate paint that shows signs of damage or deterioration.
5. **Mask** off all safety decals, cylinder shafts and vents before painting.

**WARNING:** Paint over spray on the cylinder shaft(s) or vent(s) will damage the cylinder seals and void warranty.

6. After proper cleaning and surface preparation, **Apply** desired finish coat per paint manufacturer's recommendations.
7. **Remove** the masking from the safety decals and cylinders.
8. **Check** to ensure that all decals are clean and legible. Additional decals are available from the factory, if needed.

## WIRE ROUTING

- (1) When routing wires, avoid heat (above 200°F), abrasion, vibration, metal edges, screws, and trim fasteners. If such routings are not possible, protective devices must be used. If wires must cross a metal edge, the edge should be covered with a protective shield and the wiring fastened within 3 inches on each side of the edge.
- (2) Grommets must be used where wires pass through holes in sheet metal, castings, and / or frame rails. Do not bend wires in a radius smaller than 10 times the wire diameter.
- (3) Routing wires into areas exposed to wheel wash should be avoided. If this cannot be avoided protective shields are required to protect the wires from stones, ice, salt and water damage. Provide a drip loop to prevent moisture from being conducted into switches, relays, circuit breakers, and fuses.
- (4) Wires should be supported every 18 inches with plastic zip ties or rubber-lined clips.
- (5) Wires must be routed to clear moving parts by at least 3 inches unless positively fastened or protected by a conduit. If wiring must be routed between two members where relative motion can occur, the wiring should be secured to each member, with enough wire slack to allow flexing without damage to the wire.
- (6) Maintain at least a 6 inch clearance from exhaust system components. If this is not possible, high temperature insulation and heat shields are required. Existing OEM heat shields, insulation, and wire shielding must be maintained.
- (7) Do not route or attach electrical wires to fuel lines. Route electrical wires at least 1-1/2 inches away from the engine.

## BATTERY, WIRE, TERMINALS, AND CONNECTORS

- (1) Wire attachments at the battery must be protected from tension loads so there is no undue strain on the battery terminals. Wires should be routed down rather than horizontally from the terminals with no sharp bends adjacent to the connections.
- (2) Battery power for your Tommy Gate should come directly from the battery through the supplied circuit breaker or fuse. The circuit breaker or fuse should be installed as close to the battery as possible.
- (3) Do not splice battery cables. If splicing is necessary, the most durable splice joint will be bare metal barrel crimped, flow-soldered and covered with adhesive lined heat shrink tubing. Strip the wire ends making sure that individual conductor strands are not damaged. Use only rosin core solder, proper crimping tools, and wire with a gauge at least equivalent to the circuit being lengthened. Do not use electrical tape.
- (4) Battery cable terminals will be bare metal barrel crimped or flow-soldered and covered with adhesive lined heat shrink tubing.
- (5) Use wire connectors with locking features such as positive locking, inertia locking, bolt together, and soft mold-over with locking external retainers.

## GENERAL

- (1) All frame contact areas must be wire brushed to bare metal, free of paint, dirt, and grease. Frame connections must be made using hardened flat washers under the bolt head and lock nuts. Corrosion preventive grease or compound is to be applied to the terminal area of the frame connection.
- (2) Frame cross members are not recommended as part of the ground return.
- (3) All circuit breakers and fuses should be located in one easily serviceable location with a means provided for identification of circuit function and current rating. Do not put circuit breakers or fuses in the vehicle cab.
- (4) Before welding to the chassis disconnect the battery. Also disconnect the power train, engine, valve, and transmission control modules.
- (5) Do not alter vehicle ignition, starting, and / or charging systems. Do not reroute engine compartment wiring.
- (6) Full copper circuitry and standardized polarity grounds are recommended.
- (7) Never increase the rating of a factory installed fuse or circuit breaker.
- (8) Disconnect the battery negative (ground) wire prior to any vehicle modification.

Following the above guidelines will provide you with years of trouble free service. Failing to incorporate the above guidelines will result in a voided warranty. Non-compliance with the guidelines above may result in a failure of electrical components, shutdown of engines, loss of backup brake systems, and the possibility of fire.