

# G<sup>2</sup> dual drive® Pickup Lift Mounting Instructions

Fullsize Dodge Trucks-  
1500 2002-present  
2500 & 3500 2003-present

# G-330

## Preparing the Gate

1. Remove the mounting hardware which is banded to the liftgate.
2. Verify mounting bracket kit (Figure 1 and Table 1).

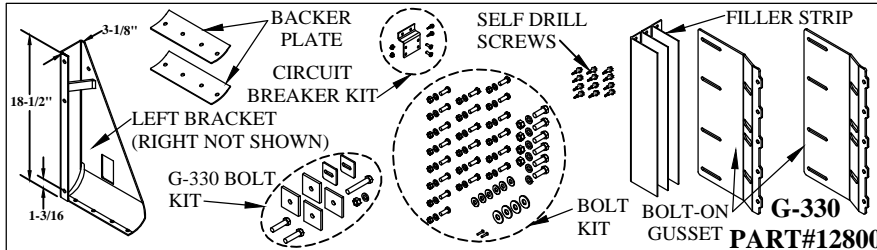

Figure 1: Part Identification.

Table 1: Parts List.

QTY.	PART NO.	DESCRIPTION
1	9094	Standard Pickup Bracket Bolt Bag Kit
1	9999	T-330 Bolt Bag Kit
1	6487	T-330 Left Corner Bracket
1	6488	T-330 Right Corner Bracket
2	5085	12GA.x3"x9" Ford Backer Plate
3	12799	12GA.x5.28"x19.5" G-330 Filler Strip
2	13174	T-330 Bolt-on Gusset
12	13180	#12x3/4" Self-Drilling Screw
1	14196	Circuit Breaker Bracket Kit

3. Support the liftgate; it will not stand upright without the angle irons.
4. Unbolt the two (2) angle irons attached to the liftgate uprights (Figure 2).
5. Unbolt the long angle iron from the bottom of the liftgate (if equipped).
6. Remove the two (2) bracket plates attached to the liftgate (Figure 2).

Note: The G<sup>2</sup> Shipping hardware is not used for this application.

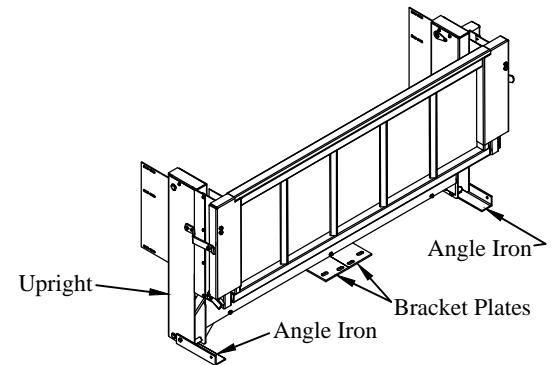

Figure 2: Complete liftgate (G<sup>2</sup> shown).

## Installing the Bolt-on Gussets

1. Install the eight (8) 3/8" x 1" button head bolts, lock washers, and nuts in the position shown for your configuration (Figure 3).
  - G<sup>2</sup> dual drive® bolt-on gussets and button head bolts go to the outside of the 1/4" x 1" strip.

Note: The extra hole in the bolt-on gusset is always below the 1/4" x 1" strip (Figure 4).

Note: If gussets are already welded to the uprights, you will need a gusset extender kit (part number 6335).

Contact Tommy Gate for instructions (712-847-8000).

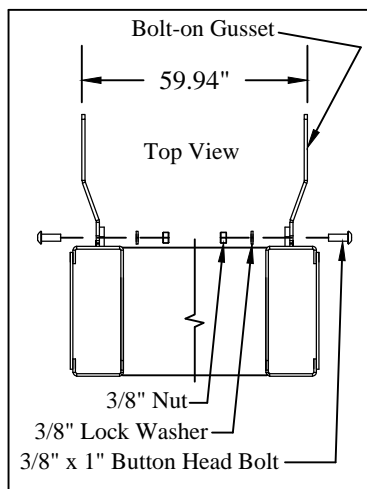

Figure 3: Top view of liftgate bolt-on gussets.

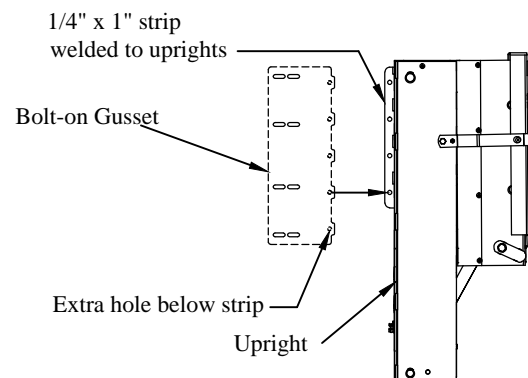

Figure 4: Liftgate requiring bolt-on gussets.

**Preparing the Truck**

- 1. Remove** the tailgate. The tailgate hardware does not need to be removed.
- 2. Unbolt** the tie down hooks (Figure 5).  
If the tie down hooks are welded in, they do not need to be remove.
- 3. Remove** the rear bumper mounting bolts and bumper.  
The bumper and bumper mounting brackets cannot be remounted after the liftgate is installed.

Note: The factory tube and/or receiver hitch should not be removed.  
The lift gate is designed to fit over the factory receiver hitch.

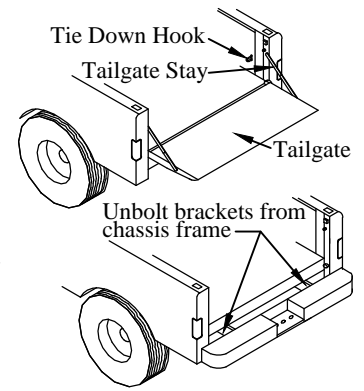

Figure 5: Remove Hardware.

**Modifying the Tail Light Mounting**

Note: This modification must be completed before the liftgate is installed so that the tail light bulbs can be replaced without removing the liftgate.

Note: This modification may not be needed. Check if the tail light screws can be accessed through the clearance holes in the liftgate gussets.

- 1. Remove** the two (2) factory tail light screws from each tail light lens (Figure 6).  
The screws will not be reused after the modification.
- Carefully **Drill** a 9/64" hole through each tail light lens and internal sheet metal (Figure 6).
- Carefully **Drill** a 3/16" hole through each tail light lens only, for screw clearance.

Note: Do not install the tail lights now if **G<sup>2</sup>** 1500 lb application.

- 4. Apply** clear silicone sealant to the 3/16" holes in the tail light lenses and stainless self-tapping screws.
- 5. Install** a stainless self-tapping screw, supplied, into each 9/64" hole to hold the tail light lenses in place (Do not over-tighten).

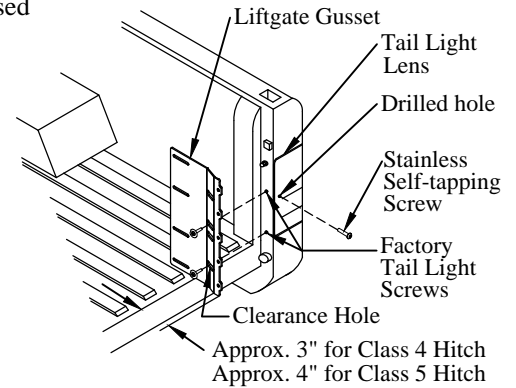

Figure 6: Tail light modification detail (if needed).

**Modifying the Spare Tire Crankshaft**

Note: This modification must be completed before the liftgate is installed.

Note: This modification allows access to the spare tire crank mechanism after the liftgate is installed.

- 1. Remove** the plastic spare tire access grommet from the back of the truck box (Figure 7).
- 2. Remove** the plastic grommet in the rear cross member of the truck frame (Figure 7).
- 3. Drill** a 1-1/4" diameter hole, centered above the existing tire access hole, and 2-5/8" down from the top of the box (Figure 8). Some trucks have a vibration damper that conflicts with the drilled hole, the damper can be removed.

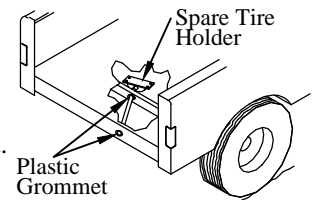

Figure 7: Spare tire access modification.

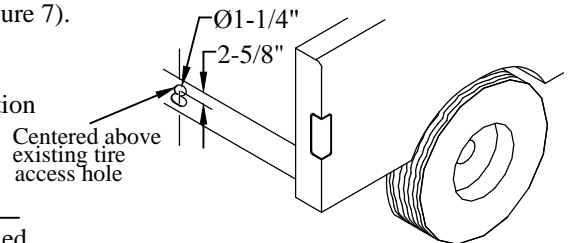

Figure 8: Spare tire access hole location.

**Installing the Filler Strip**

Note: The filler strip must be mounted on the liftgate before the liftgate is installed.

Note: The filler strip will fill the gap between the liftgate and the truck bed.

- 1. Arrange** the three (3) 12ga. x 5-9/16" x 19-1/2" G-330 filler strips end to end with the short flange flat against the back of the liftgate mainframe and the top even with the top of the top of the mainframe.
- 2. Avoid** obstructions inside the mainframe box while attaching filler strips.
- 3. Attach** the three (3) filler strips to the mainframe with the provided self drilling screws.

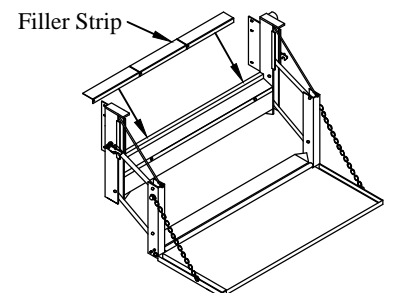

Figure 9: Filler strip placement.

**Removing the Knockouts**

**Note:** This modification must be done before the liftgate is installed, so the liftgate will fit over the Dodge factory receiver hitch.

1. **Verify** how many of the knockouts need to be removed.  
This can be done by looking at the *Installing the Lower Mount* sections on page 7.
2. **Remove** the 2-1/4" knockouts from the bottom of the mainframe using a screw driver and a pair of pliers (Figure 10).

**Note:** If the liftgate you are mounting does not have the knockout holes, they must be added. Contact Tommy Gate for instructions (712-847-8000).

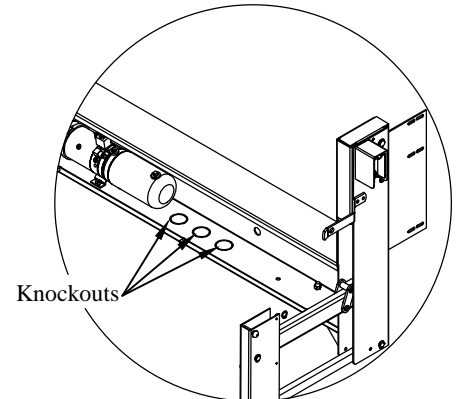

Figure 10: Knockout hole location.

**Installing the Liftgate**

1. **Position** the mounting brackets into the truck bed in front of the corner posts (Figure 11).  
Do not drill holes for mounting brackets at this time.
2. **Position** the Tommy Lift into the bed opening. The liftgate should be:
  - Aligned with spare tire tube.
  - Centered in the opening.
  - Flush with the truck bed floor.
  - In a vertical position (level with the ground).
3. **Hand tighten** each mounting bracket to the liftgate gussets using the supplied:
  - (3) 3/8"x1" hex head bolts on the bracket-side (Figure 11).
  - (3) 3/8" lock washers, and (3) 3/8" nuts on the gusset-side (Figure 11).
4. **Allow** the liftgate to hang, supported by the corner posts.
5. **Hold** the bracket against the corner post.
6. **Check** for obstructions before drilling in the next step.

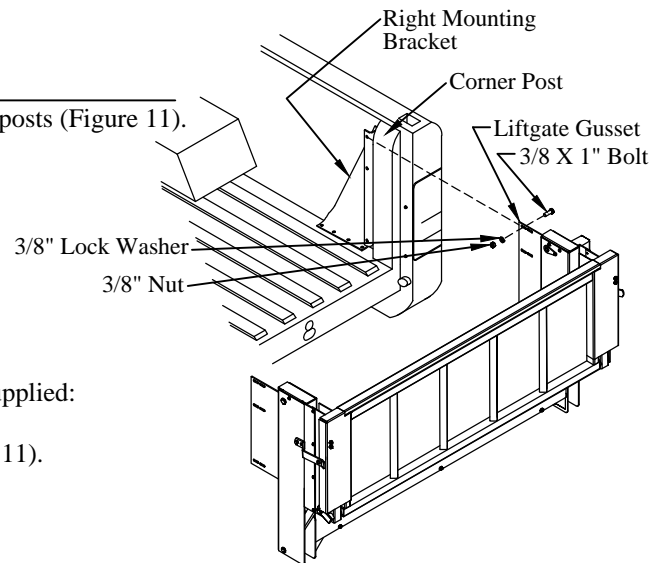

Figure 11: Mounting bracket and liftgate.

7. **Drill** two (2) 3/8" holes into the truck bed floor using two holes in the bracket as a guide.  
Choose two of the four holes provided with no obstructions on the underside (Figure 12).
8. **Fasten** each bracket to the truck box using the supplied:
  - (2) 3/8"x1" hex head bolts on the top-side (Figure 12).
  - (1) backer plate, (2) lock washers, and (2) hex nuts on the under-side (Figure 12).

**Note:** Ensure that the bracket contacts the top of the corner post. One or two 3/8" flat washers may be needed between truck bed and bracket for this purpose.  
**Note:** Backer plates may need to be trimmed to fit.

9. **Adjust** the liftgate so the platform is level from front to back.  
Check the clearance between the truck tail light lenses and the liftgate.

10. **Tighten** the bolts securing the liftgate gusset to the mounting brackets.  
The lock washer split must not be in the gusset slot when tightening bolts.

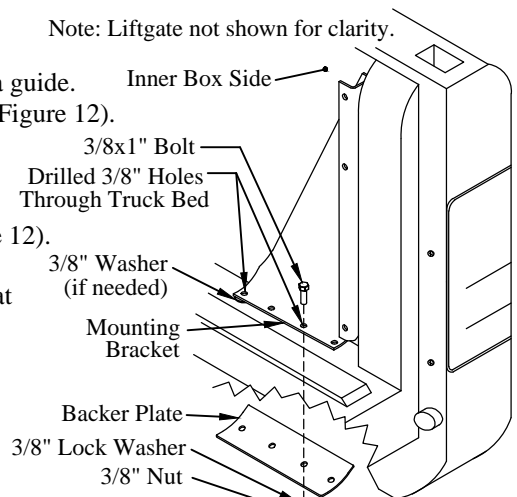

Figure 12: Mounting bracket and backer plate.

**Adding Additional Support (G<sup>2</sup>®1500 lb Application Only)**

Note: Additional bracket support is required at this capacity.

1. **Locate** the existing 3/8" hole in the mounting bracket (Figure 13).
2. **Check** for obstructions before drilling in the next step.
3. **Drill** a 3/8" hole in the inner box side, using the bracket's hole as a guide.  
If a hole already exists, be sure to use the provided backer plate in the next step.
4. **Fasten** the mounting bracket to the inner box side using the supplied (Figure 13):
  - (1) 3/8" lock washer and (1) 3/8" nut on the bracket-side.
  - (1) 3/8"x1" hex head bolt, (1) 3/8" flat washer, and (1) backer plate on the truck-side.
5. **Repeat** for the other mounting bracket.
6. **Install** tail light lenses.

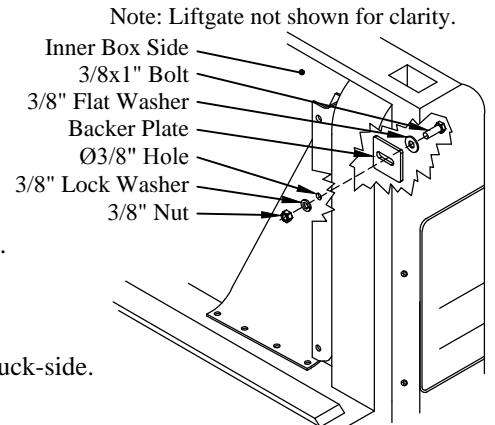

Figure 13: Additional support location.

**Checking Spare Tire Access**

Note: There is a hole in the box cover and mainframe that provides access to the spare tire crank mechanism.

1. **Remove** the box cover by removing the 5/16" hex head nuts (Figure 14).
2. **Remove** the black plastic plug from the mainframe in the locations shown (Figure 15).
3. **Insert** the spare tire crank rod through the hole in the mainframe.
4. **Verify** that the spare tire crank access is working properly.

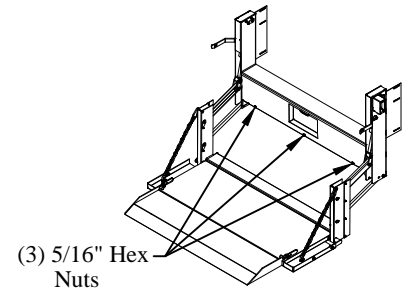

Figure 14: Box cover locations.

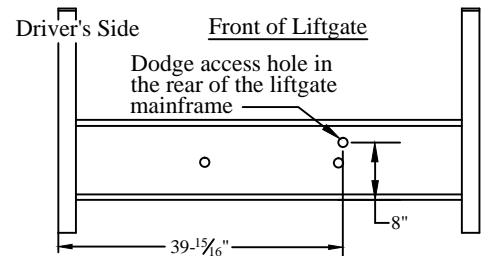

Figure 15: Spare tire access.

**Preparing the Gate for Wiring**

1. **Unscrew** the solid plastic plug from the pump reservoir. The box cover should already be off.

Note: The hydraulic system has already been filled with the proper amount of hydraulic oil so **do not** add any oil at this time.

2. **Attach** 12 volts from a battery to the liftgate power cables (no battery chargers).

3. **Push** the hidden "Power On" switch (Figure 19). The amber "Power On" LED will illuminate.

4. **Push** the hidden "Liftgate Activated" switch twice within one second. The red "Liftgate Activated" LED will illuminate.

Note: With both lights on, the liftgate can be raised or lowered. If not used for 90 seconds, the control will automatically shut off.

5. **Push** the toggle switch down to lower the liftgate to the ground.

6. **Remove** the following from inside the liftgate mainframe:

- Owner/Operator Manual
- License plate light(s)
- License plate light hardware
- (1) Vent plug
- (1) 150 Amp manual reset circuit breaker
- (4) Copper lugs
- (2) License plate nuts and screws
- (1) Padlock with keys
- (5) 3/8" plastic plugs
- (1) Drop away pin
- (1) Lower mounting kit

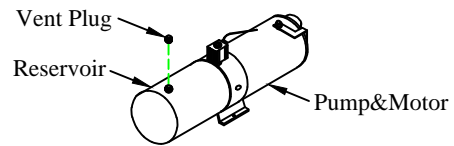

Figure 16: Vent plug.

7. **Install** the vent plug provided into the pump reservoir (Figure 16).

**Routing the Power Cables**

1. **Install** the circuit breaker on the circuit breaker bracket with 1/4" screws and nuts (Figure 17).

2. **Install** the circuit breaker on the vehicle fender, inside the engine compartment away from moving parts.  
Leave enough room for the power cables to be installed and so that the circuit breaker can easily be reset.

3. **Loosen** the strain relief on the back of the liftgate mainframe (Figure 18).

\*Verify battery polarity. Older trucks may have different battery orientation.

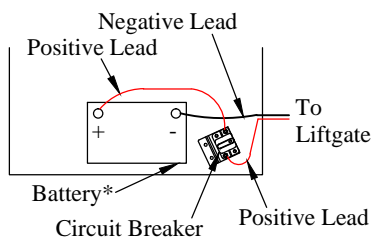

Figure 17: Circuit breaker bracket.

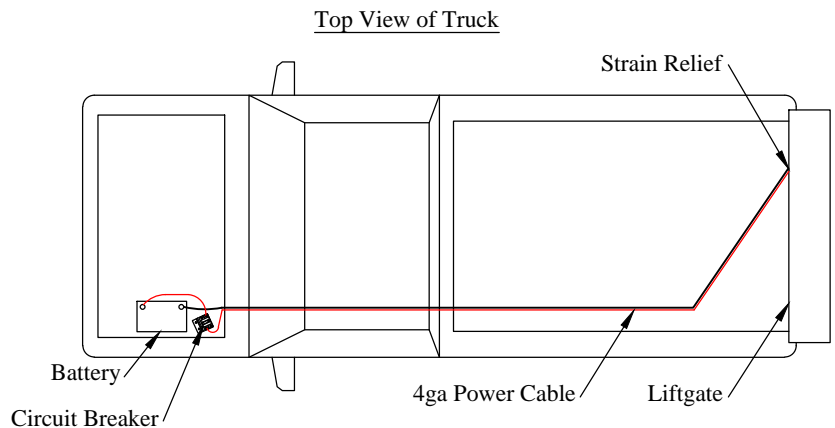

Figure 18: Electrical routing.

**Routing the Power Cables (continued)**

4. **Pull** the power cable (coiled up in the liftgate mainframe) carefully through the strain relief. Leave approximately two (2) inches of slack inside the liftgate mainframe (Figure 18).
5. **Tighten** the strain relief.
6. **Route** the power cables along the frame (Figure 18) to the battery following the *Tommy Gate Recommended Electrical Wiring Guidelines*.
7. **Pull** the excess cable beyond the battery.
8. **Separate** the positive(+) and negative(-) leads.
9. **Cut** the positive(+) lead to the length required to reach the auxiliary (AUX) terminal of the circuit breaker.
10. **Cut** the remaining pos.(+) lead long enough to reach from the circuit breaker battery (BAT) terminal to the pos.(+) battery terminal.
11. **Cut** the negative(-) lead to a length required to reach the negative battery terminal.

**IMPORTANT:** The pump and motor unit for this lift can require up to 205 amps of electrical power at 12 volts D.C. Be sure that the negative(-) ground lead is connected to the negative(-) terminal of the vehicle battery.

12. **Install** the copper lugs on all required ends.
13. **Connect** the circuit breaker and battery as outlined in the *Tommy Gate Recommended Electrical Wiring Guidelines* and wiring diagram (Figure 19).

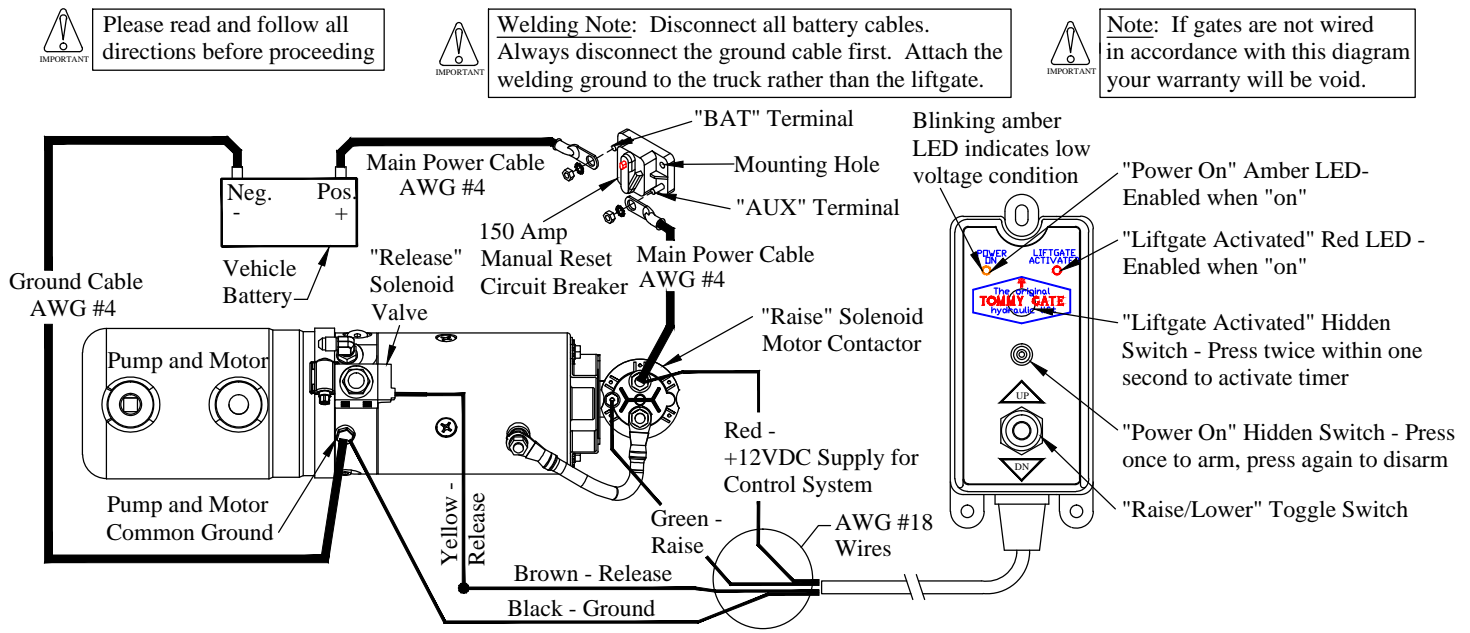

Figure 19: Wiring diagram.



**Installing the Lower Mount (Class 4 Hitch)**

1. **Assemble** the supplied hardware through the center hole in the bottom of the liftgate mainframe and the center hole in the factory hitch plate on the truck (Figure 20).

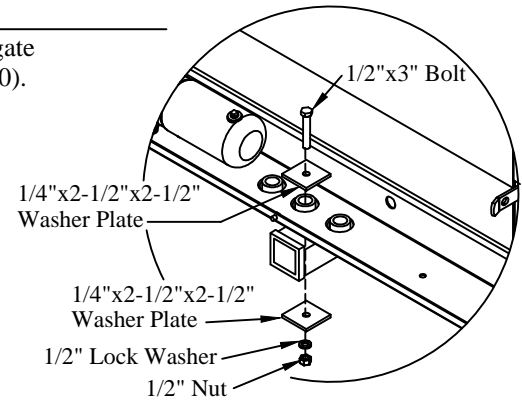

Figure 20: Lower bracket support (Class 4 hitch).

**Installing the Lower Mount (Class 5 Hitch)**

1. **Assemble** the supplied hardware through the outer two holes in the bottom of the liftgate mainframe and the two holes in the factory hitch plate on the truck (Figure 21).
2. **Add** the supplied 7GA bracket plates between the liftgate and the factory hitch plate to raise the top of the liftgate to bed height, if needed.

Note: The bracket plates will need to be modified.  
 Note: Be sure the bracket plates will not interfere with the spare tire or backup bar, if one will be installed.

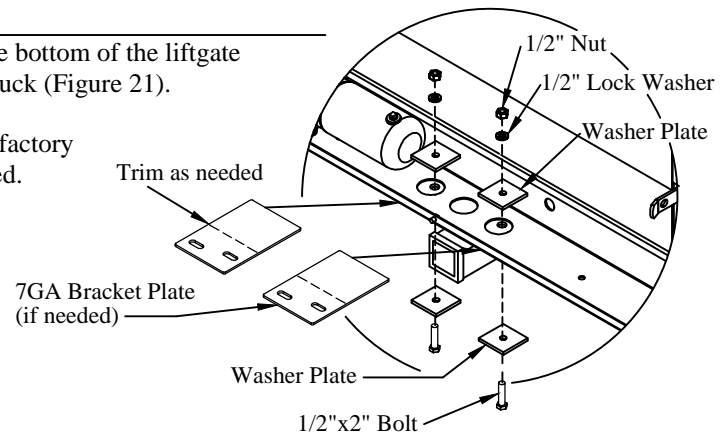

Figure 21: Lower bracket support (Class 5 hitch).

**Finishing the Liftgate Installation**

1. **Install** the two (2) square plastic insert nuts for the license plate into the square holes on the liftgate.
2. **Install** the license plate using the two (2) stainless steel screws provided.
3. **Install** the license plate light(s) into the holes provided.
4. **Connect** the license plate light(s) to the vehicle's wiring following the *Tommy Gate Recommended Electrical Wiring Guidelines*. The license plate light wire(s) can be run through the strain relief in the back of the liftgate.

Note: Additional wire may need to be spliced into the license plate light circuit to reach the connection point.  
 Note: All electrical splices should be heat shrunk for corrosion protection.

5. **Install** the 3/8" round plastic plugs into the empty holes in the bottom of the uprights.  
 See the Owner's / Operator's Manual if drop away feature is desired.
6. **Install** the "Do's and Do Not's" decal in a highly visible area in the vehicle cab.  
 This decal is with the Owner's / Operator's Manual.
7. **Reinstall** the spare tire, if previously removed.

## Testing the Operation of the Liftgate

**CAUTION:** Keep all foreign objects (body parts, tools, load weights, etc) out of the liftgate mainframe and away from pinch points at all times when operating the liftgate.

1. **Check** operation of the safety control for proper lift operation.  
Be sure the control shuts off automatically after 90 seconds of not being used.
2. **Raise** and **Lower** the unloaded platform on a flat surface looking for proper operating speed and alignment with the ground.
3. **Load** the platform with the rated capacity and **Measure** the time necessary to raise the platform.  
The platform should raise at roughly 2-3 inches per second.
4. **Examine** the platform for any downward creep.
5. **Time** the lowering operation with the platform still loaded.  
The load should descend at roughly 7-9 inches per second.
6. **Remove** the load from the platform and **Examine** the liftgate and vehicle for any problems such as hydraulic oil leaks, loose wiring, etc.
7. **Reinstall** the box cover.
8. **Close** and **Latch** the platform.
9. **Lock** the padlock through the hole in the platform or latch pin (Figure 22).
10. **Place** Owner's / Operator's Manual and padlock keys in the vehicle.

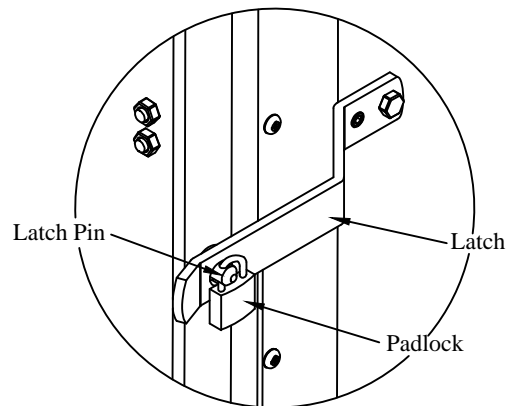

Figure 22: Padlock location.



### Painting the Liftgate (if needed)

Your Tommy Gate has been primed with a gray polyurethane and painted with a black semi-gloss polyurethane topcoat to protect it from the environment. No additional paint is required unless shipping or installation damage or outdoor storage exposure has deteriorated the Tommy Gate paint. **Tommy Gate will not be responsible for shipping or installation damage or outdoor storage exposure that has marred or otherwise deteriorated the Tommy Gate paint.**

If you need to refinish the liftgate you should do the following:

1. **Remove** any dirt, oil, grease, salt, or other contamination by washing with a mild detergent solution.
2. **Rinse** thoroughly with fresh water and allow to dry.
3. Lightly **Scuff Sand** the Tommy Gate topcoat.
4. **Sand** and **Spot Prime** any area of the Tommy Gate paint that shows signs of damage or deterioration.
5. **Mask** off all safety decals, cylinder shafts and vents before painting.

**WARNING:** Paint overspray on the cylinder shaft(s) or vent(s) will damage the cylinder seals and void warranty.

6. After proper cleaning and surface preparation, **Apply** desired finish coat per paint manufacturer's recommendations.
7. **Remove** the masking from the safety decals and cylinders.
8. **Check** to ensure that all decals are clean and legible. Additional decals are available from the factory, if needed.

### **WIRE ROUTING**

- (1) When routing wires, avoid heat (above 200°F), abrasion, vibration, metal edges, screws, and trim fasteners. If such routings are not possible, protective devices must be used. If wires must cross a metal edge, the edge should be covered with a protective shield and the wiring fastened within 3 inches on each side of the edge.
- (2) Grommets must be used where wires pass through holes in sheet metal, castings, and / or frame rails. Do not bend wires in a radius smaller than 10 times the wire diameter.
- (3) Routing wires into areas exposed to wheel wash should be avoided. If this cannot be avoided protective shields are required to protect the wires from stones, ice, salt and water damage. Provide a drip loop to prevent moisture from being conducted into switches, relays, circuit breakers, and fuses.
- (4) Wires should be supported every 18 inches with plastic zip ties or rubber-lined clips.
- (5) Wires must be routed to clear moving parts by at least 3 inches unless positively fastened or protected by a conduit. If wiring must be routed between two members where relative motion can occur, the wiring should be secured to each member, with enough wire slack to allow flexing without damage to the wire.
- (6) Maintain at least a 6 inch clearance from exhaust system components. If this is not possible, high temperature insulation and heat shields are required. Existing OEM heat shields, insulation, and wire shielding must be maintained.
- (7) Do not route or attach electrical wires to fuel lines. Route electrical wires at least 1-1/2 inches away from the engine.

### **BATTERY, WIRE, TERMINALS, AND CONNECTORS**

- (1) Wire attachments at the battery must be protected from tension loads so there is no undue strain on the battery terminals. Wires should be routed down rather than horizontally from the terminals with no sharp bends adjacent to the connections.
- (2) Battery power for your Tommy Gate should come directly from the battery through the supplied circuit breaker or fuse. The circuit breaker or fuse should be installed as close to the battery as possible.
- (3) Do not splice battery cables. If splicing is necessary, the most durable splice joint will be bare metal barrel crimped, flow-soldered and covered with adhesive lined heat shrink tubing. Strip the wire ends making sure that individual conductor strands are not damaged. Use only rosin core solder, proper crimping tools, and wire with a gauge at least equivalent to the circuit being lengthened. Do not use electrical tape.
- (4) Battery cable terminals will be bare metal barrel crimped or flow-soldered and covered with adhesive lined heat shrink tubing.
- (5) Use wire connectors with locking features such as positive locking, inertia locking, bolt together, and soft mold-over with locking external retainers.

### **GENERAL**

- (1) All frame contact areas must be wire brushed to bare metal, free of paint, dirt, and grease. Frame connections must be made using hardened flat washers under the bolt head and lock nuts. Corrosion preventive grease or compound is to be applied to the terminal area of the frame connection.
- (2) Frame cross members are not recommended as part of the ground return.
- (3) All circuit breakers and fuses should be located in one easily serviceable location with a means provided for identification of circuit function and current rating. Do not put circuit breakers or fuses in the vehicle cab.
- (4) Before welding to the chassis disconnect the battery. Also disconnect the power train, engine, valve, and transmission control modules.
- (5) Do not alter vehicle ignition, starting, and / or charging systems. Do not reroute engine compartment wiring.
- (6) Full copper circuitry and standardized polarity grounds are recommended.
- (7) Never increase the rating of a factory installed fuse or circuit breaker.
- (8) Disconnect the battery negative (ground) wire prior to any vehicle modification.

Following the above guidelines will provide you with years of trouble free service. Failing to incorporate the above guidelines will result in a voided warranty. Non-compliance with the guidelines above may result in a failure of electrical components, shutdown of engines, loss of backup brake systems, and the possibility of fire.