

T-54/T-64 Light Kit Mounting Instructions

NOTE: Connecting liftgate lights to the truck's trailer tow harness may disable park aid features on trucks with trailer detection capabilities. To avoid this, it may be necessary to connect to the truck's tail light wiring or trailer tow harness using a relay. Tommy Gate offers a relay kit (PN 15863) for these situations. The relay kit minimizes the amount of electrical load on the vehicle's factory wiring. See page 5 for more information.

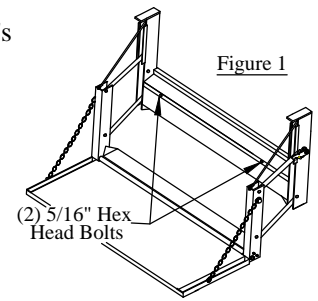

Step 1. Lower the liftgate to the ground. To avoid a risk of a 12 volt electrical short, disconnect the #4 power cable from the positive side of the battery or manually trip the circuit breaker.

Step 2. Remove the mainframe box cover by taking out the two 5/16" hex head cap screws with a 1/2" wrench or socket.

Step 3. Locate an unused 1.25" hole in the rear of the mainframe to use to connect the harness in the liftgate to the harness on truck. If there are no 1.25" holes available, either create a new 1.25" access hole in the back of the liftgate or drill out the drain hole in the bottom of the liftgate to 1.25" (Figure 2).

Check for obstructions before drilling.

Step 4. Remove plastic plugs from access holes (Figure 3).

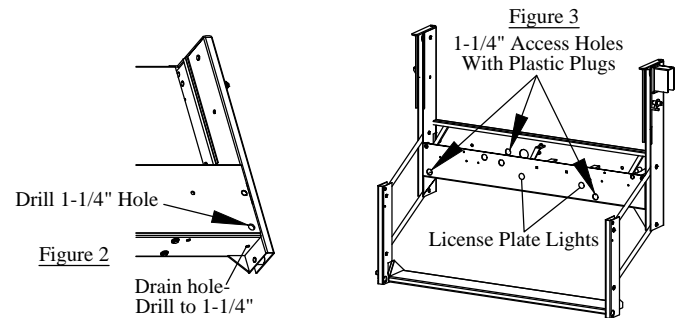

Step 5. Route the harness through the access holes.

A. For the T-64 kit, pull two 3-prong light clip through each 1-1/4" access hole (Figure 3).

For the T-54 kit, pull two 2-prong light clips and a 3-prong light clip through each 1-1/4" access hole (Figure 3).

NOTE: Make sure that the clip with the yellow wire is on the driver's side and the clip with the green wire is on the passenger's side.

B. Locate the two brown wires and the two white wires without any clips on them.

-If the license plate light has two wires:

Connect one brown wire to the red wire on the light using a heat shrink butt connector.

Connect one white wire to the black wire on the light using a heat shrink butt connector.

-If the license plate light has only one wire:

Connect one brown wire to the black wire on each light using a heat shrink butt connector.

Bend one of the white wires to a 180° bend. Wrap the exposed wire end with heat shrink (Figure 4).

Ground one of the white wires to the common ground bolt on the power unit.

C. Pull the end of the harness with all the wires through the 1-1/4" drilled hole (Figure 2)

NOTE: Leave harness draped loosely in mainframe until all components are installed.

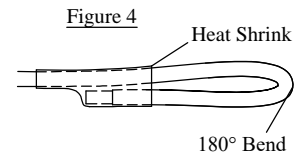

Step 6. Install 1-1/4" rubber grommets in access holes.

A. Cut the 1-1/4" grommet from the inner hole out (Figure 5).

B. Place 1-1/4" grommet around wires (Figure 5)

C. Push 1-1/4" grommets into the access holes.

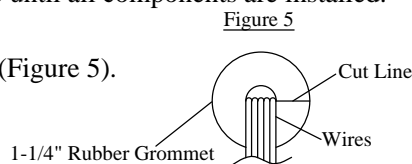

If this light kit is being installed on an older liftgate with smaller access holes or no holes at all, two 1-1/4" diameter holes must be drilled in the locations shown (Figure 6).

Check for obstructions before drilling.

Step 7. Assemble the light kit as shown using the supplied 1/4-20x3/4" bolts and 1/4-20 lock nuts. Do not tighten at this time. (Figure 7).

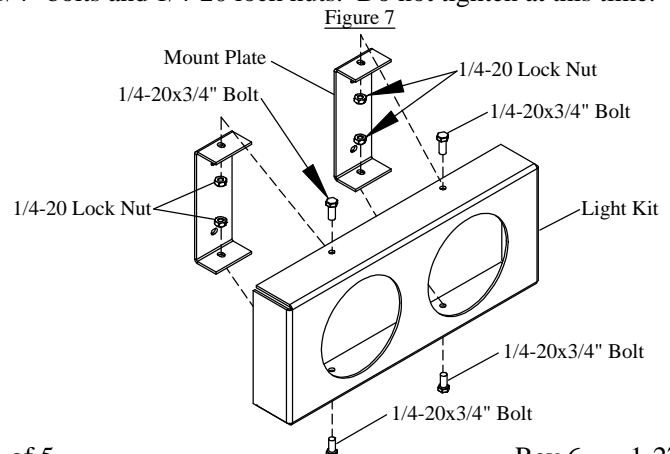
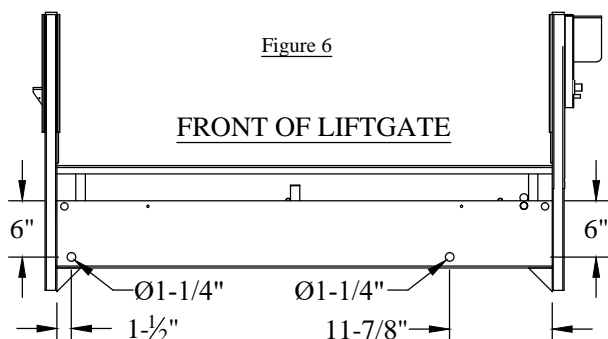

T-54/T-64 Light Kit Mounting Instructions

Step 8. Bolt the light kit to the liftgate using the supplied 1/4-20x3/4" bolts and 1/4-20 lock nuts. Tighten all bolts to 9ft-lb (Figure 9).

Figure 8



NOTE: Make sure that the warning sticker is facing up before attaching the light kit to liftgate (Figure 8).

NOTE: Before attaching the light kit to liftgate, make sure to route the harness through the back of the light kit. Making sure that no wires are pinched between the kit and the liftgate.

NOTE: If this light kit is being installed on an older liftgate without the mounting holes, the light kit must be welded on in the locations shown below (Figure 10).

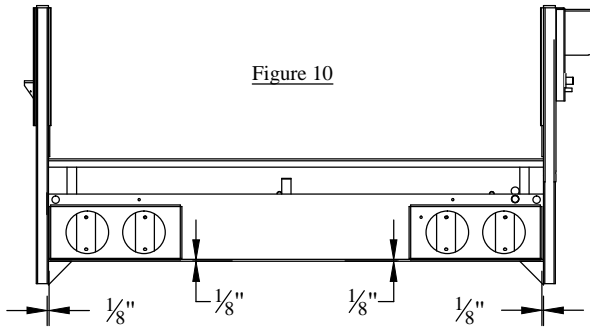

Figure 10

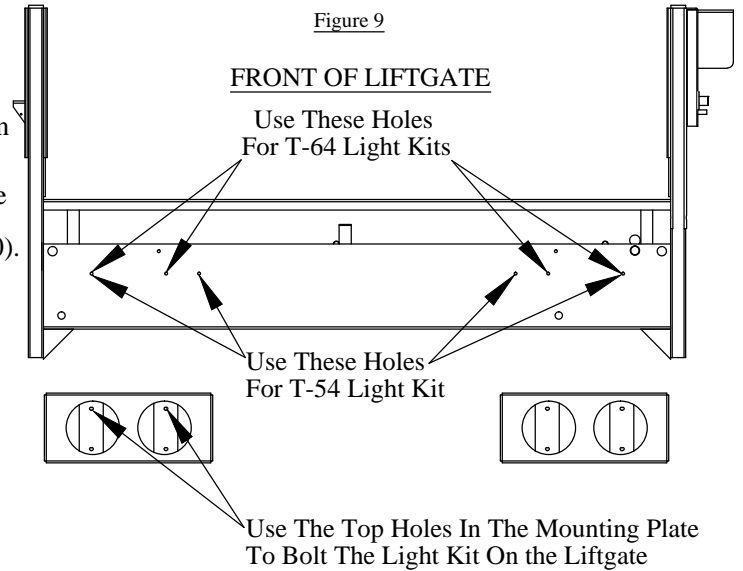

Figure 9

Step 9. Press 4-1/2" rubber grommets into light holes (Figure 11).

Step 10. Pull harness clips through the inserted 4-1/2" grommets. Connect the clips to lights (Figure 12-13).

Step 11. Connect the provided wiring harness to the vehicle's existing wiring. Follow the recommended electrical guidelines when connecting the wiring harness to the vehicle.

NOTE: If using a relay kit, install it at this time by following the relay kit's installation instructions.

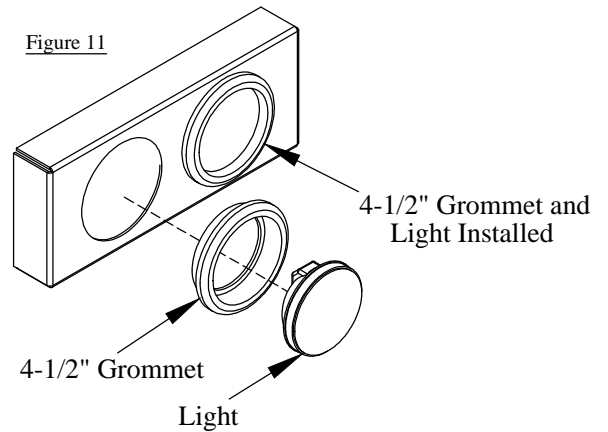

Figure 11

Step 12. Check for proper operation of lights.

Step 13. If the lights are in correct operation, push lights into installed 4-1/2" rubber grommets (Figure 11).

Step 14. Wire tie harness out of the way of moving components.

Step 15. Verify proper operation of lights.

Step 16. Reinstall the box cover on the liftgate and reconnect the liftgate's main power cable.

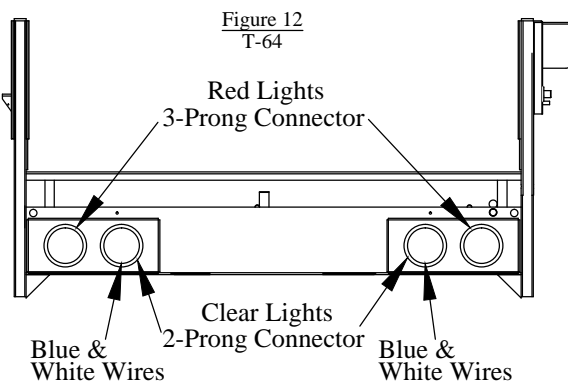

Figure 12
T-64

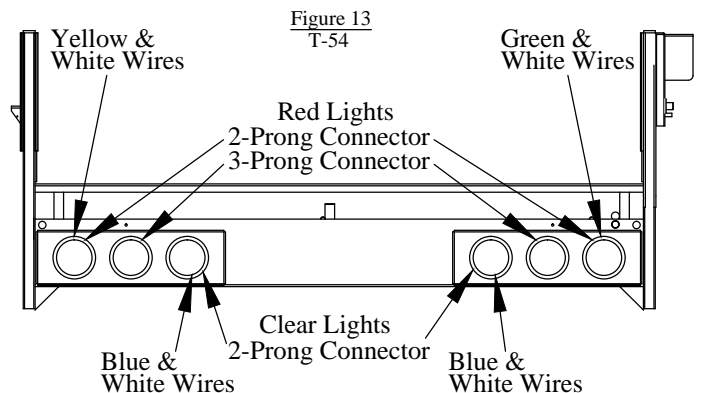

Figure 13
T-54

T-54 Light Wiring Diagrams

Electrical Guidelines:

- (1) The installer is responsible for using proper techniques when interfacing with vehicle electrical systems.
- (2) Failure to comply with the OEM guidelines could result in unsafe vehicle operation, failure of OEM wiring, or vehicle fire.
- (3) Never replace oem fuses and/or circuit breakers with fuses or circuit breakers with a higher rating.
- (4) The total circuit current draw should not exceed 80% of the OEM circuit fuse or circuit breaker.
- (5) When possible, use body builder junction blocks, customer access circuits & connectors rather than extending OEM circuits.
- (6) Incorporate relays when extending the OEM electrical system.
- (7) Use appropriate gauge wire for extending circuits. The wire gauge should be capable of supporting the maximum load to which the added circuit will be exposed.
- (8) OEM electrical wire color coding should be maintained when extending circuits.
- (9) When adding circuits, always incorporate fuse or circuit breaker protection.

Ⓢ **NOTE:** Symbol indicates usage of heat shrink butt connector.

T-54 COMBINED STOP/TURN FUNCTION

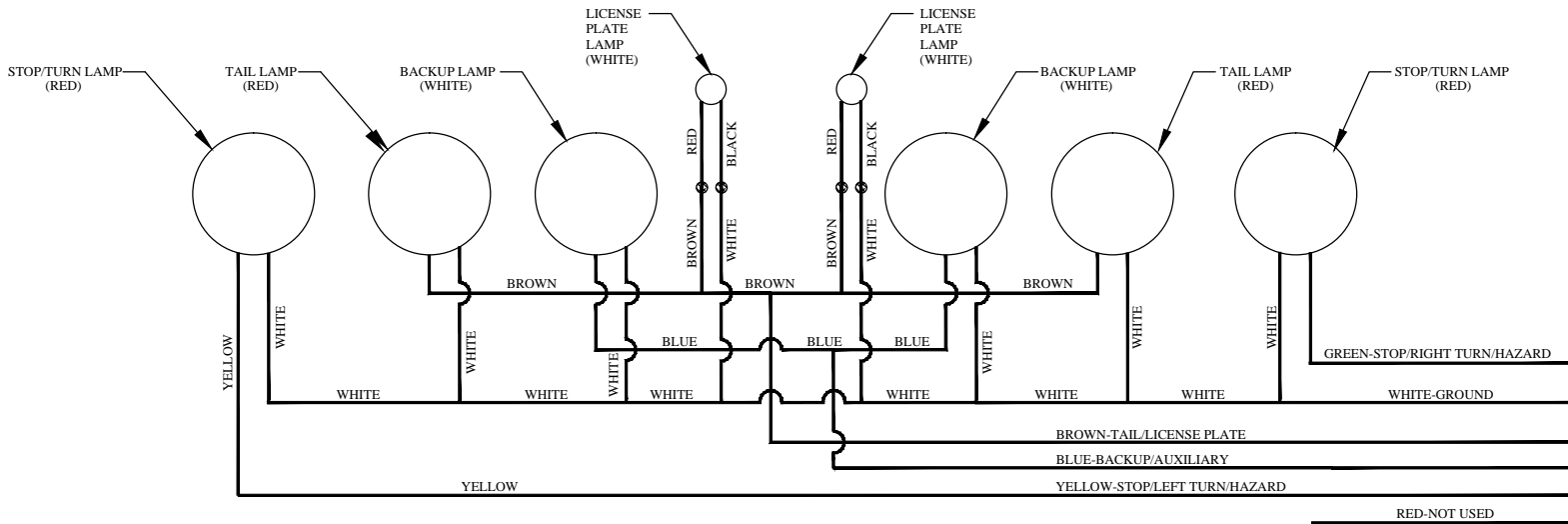

T-54 SEPARATED STOP/TURN FUNCTION

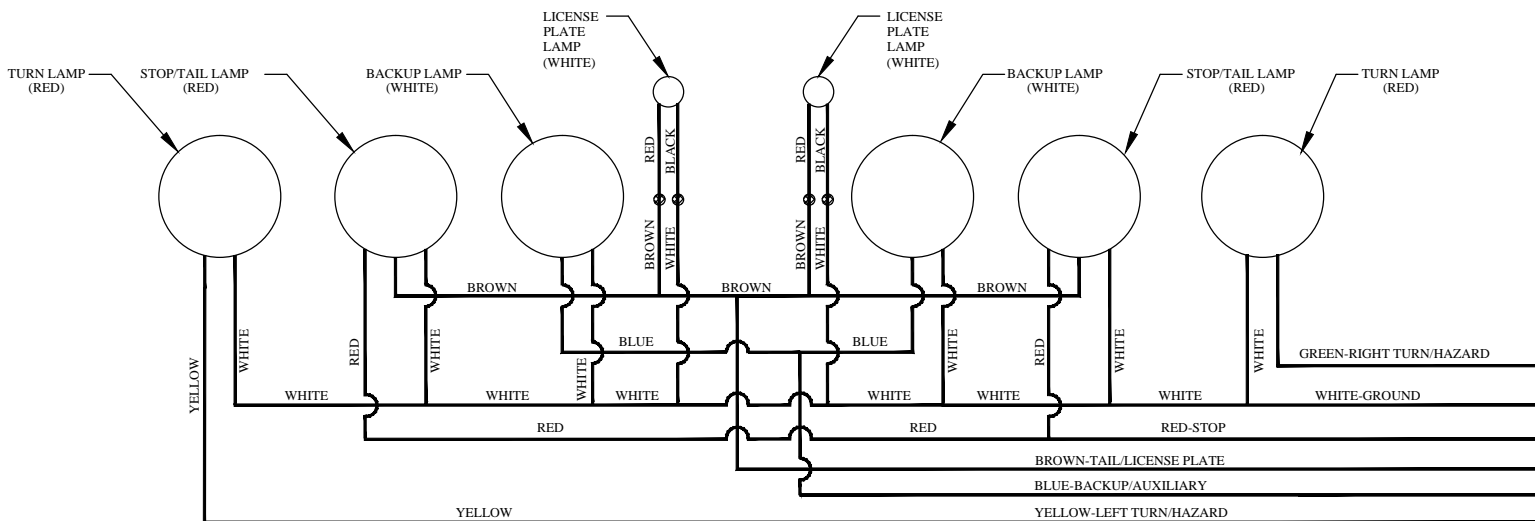

T-64 Light Wiring Diagrams

Electrical Guidelines:

- (1) The installer is responsible for using proper techniques when interfacing with vehicle electrical systems.
- (2) Failure to comply with the OEM guidelines could result in unsafe vehicle operation, failure of OEM wiring, or vehicle fire.
- (3) Never replace oem fuses and/or circuit breakers with fuses or circuit breakers with a higher rating.
- (4) The total circuit current draw should not exceed 80% of the OEM circuit fuse or circuit breaker.
- (5) When possible, use body builder junction blocks, customer access circuits & connectors rather than extending OEM circuits.
- (6) Incorporate relays when extending the OEM electrical system.
- (7) Use appropriate gauge wire for extending circuits. The wire gauge should be capable of supporting the maximum load to which the added circuit will be exposed.
- (8) OEM electrical wire color coding should be maintained when extending circuits.
- (9) When adding circuits, always incorporate fuse or circuit breaker protection.

⊗ **NOTE:** Symbol indicates usage of heat shrink butt connector.

T-64 COMBINED STOP/TURN FUNCTION

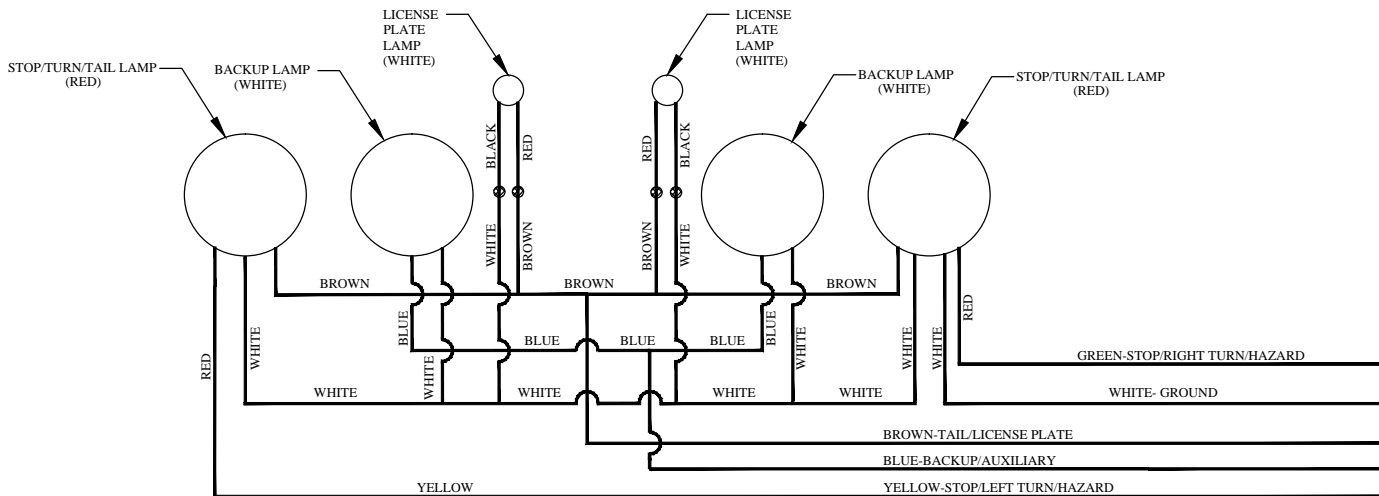

T-64 SEPARATED STOP/TURN FUNCTION

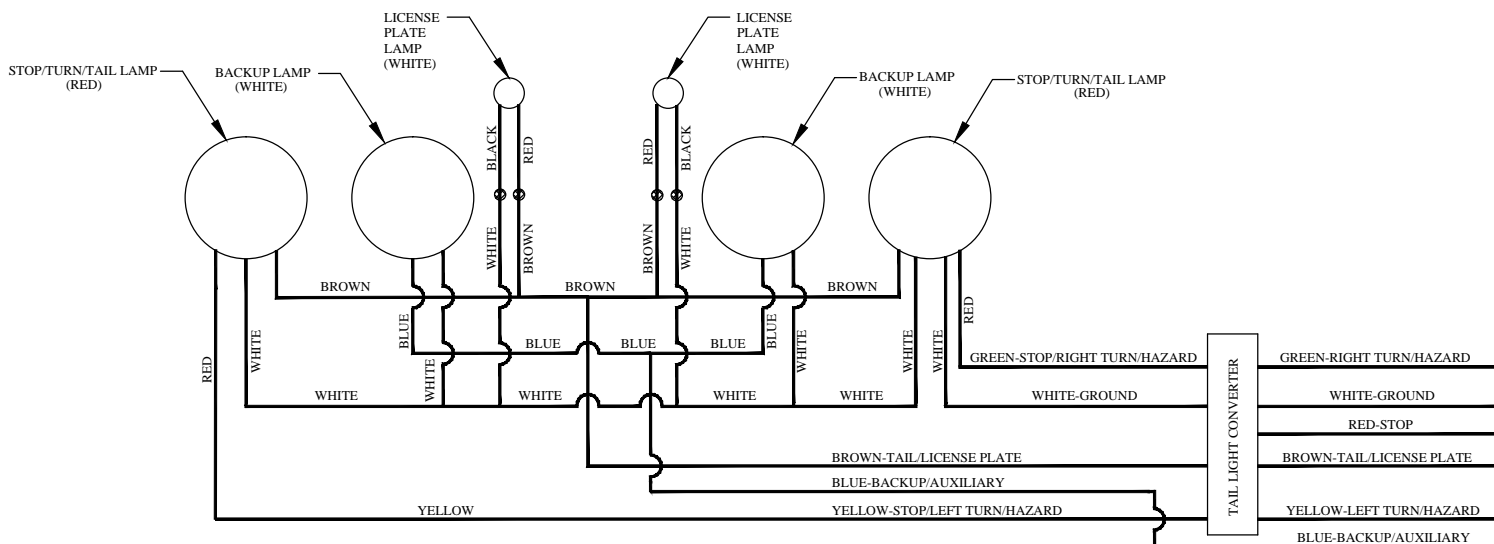

T-54/T-64, Light Relay

Tommy Gate 12V Light Relay Kit -PN 015863 (Sold Separately)

Connecting liftgate lights to the truck's trailer tow wiring may disable park aide features on trucks with trailer detection capabilities. To avoid this, it may be necessary to connect to the truck's tail light harness or trailer tow harness using a relay. Tommy Gate offers a relay kit (PN 15863) for these situations. This relay kit minimizes the amount of electrical load on the vehicle's factory wiring.

If your truck is listed in the table below and has a trailer detection system, use of a light relay kit (PN 15863) is recommended.

Table 1: Recommended Relay Applications

PICKUP MFG	YEAR	MODEL	AVAILABLE TRAILER DETECTION SYSTEM	RECOMMENDED WIRING LOCATION WITH RELAY
CHEVY	2019-2020	1500	ADVANCED TRAILERING SYSTEM	TAIL LIGHT HARNESS
	2020	2500 / 3500		TAIL LIGHT HARNESS
FORD	2019-2020	RANGER	SMART TRAILER TOW CONNECTOR	TAIL LIGHT HARNESS
	2015-2018	F-150		TRAILER TOW HARNESS
	2019-2020	F-150		TAIL LIGHT HARNESS
	2016-2020	SUPER DUTY SERIES		TAIL LIGHT HARNESS
GMC	2019-2020	1500	PROGRADE TRAILERING SYSTEM	TAIL LIGHT HARNESS
	2020	2500 / 3500		TAIL LIGHT HARNESS

NOTES:

Compatible with both combined (2-wire) and separated (3-wire) stop/turn vehicle systems

Compatible with 12-volt applications only