

12V LIGHT RELAY KIT



For 2019 Ford Ranger Combined or Separated Stop/Turn Eliminates Ford Truck False Detection of Connected Trailer

A Tommy Gate Bolt-On Light Kit may cause some Ford trucks to indicate a trailer is connected when one is not. A false trailer detection may result in deactivation of other vehicle features.

The new Tommy Gate 12V Light Relay Kit will eliminate this false trailer detection by reducing the amount of electrical load on the vehicle’s factory wiring.

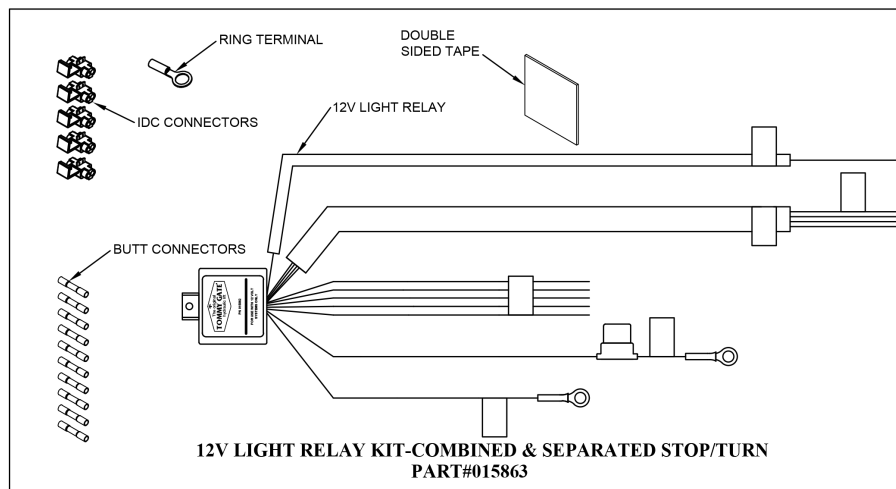

Table 1: Parts list.

QTY	PART NO.	DESCRIPTION
1	015862	12V LIGHT RELAY-COMBINED & SEPARATED STOP/TURN
10	009089	16-14 HEAT SHRINK BUTT CONNECTOR
5	015855	18-14 IDC WIRE CONNECTOR
1	013415	16-14 HEAT SHRINK 5/16" RING TERMINAL
1	015409	2"X2" DOUBLE SIDED FOAM TAPE

This relay kit is designed for 12-volt vehicles only with combined or separated stop/turn light functions.

In view of the responsibility of altered-stage vehicles, Tommy Gate offers its "12V Light Kit" as a possible solution. However, it is the sole responsibility of the upfitter/final stage manufacturer to determine if the 12V Light Kit is the solution. Any information made available by Tommy Gate regarding its 12V Light Kits is not intended to be, and shall not be, relied upon as a final determination of a solution. Each distributor must, on its own, make each such required determination for each vehicle it offers to a customer. Tommy Lifts are industrial products for material handling only and are not to be used as personnel or wheelchair lifts. For safe handling and operating instructions, visit: www.tommygate.com. Please see 12V Light Relay-Combined Stop/Turn Installation Instructions for complete installation information.

Note: Follow the *Tommy Gate Recommended Electrical Wiring Guidelines* when performing all procedures in these instructions.

Note: This relay kit is designed for use with Tommy Gate light kits installed on 12-volt vehicles with combined or separated stop/turn light functions.

APPLICATION NOTES

- General use in vehicles with combined or separated stop/turn signals
- 2019 Ford Ranger (see Table 2: Applications)
- 2015-2019 Ford F-Series with smart trailer tow connector exhibiting trailer connected message (see Table 2: Applications)

1. Verify the parts of the 12V Light Relay Kit-Combined & Separated Stop/Turn (Table 1 and Figure 1).

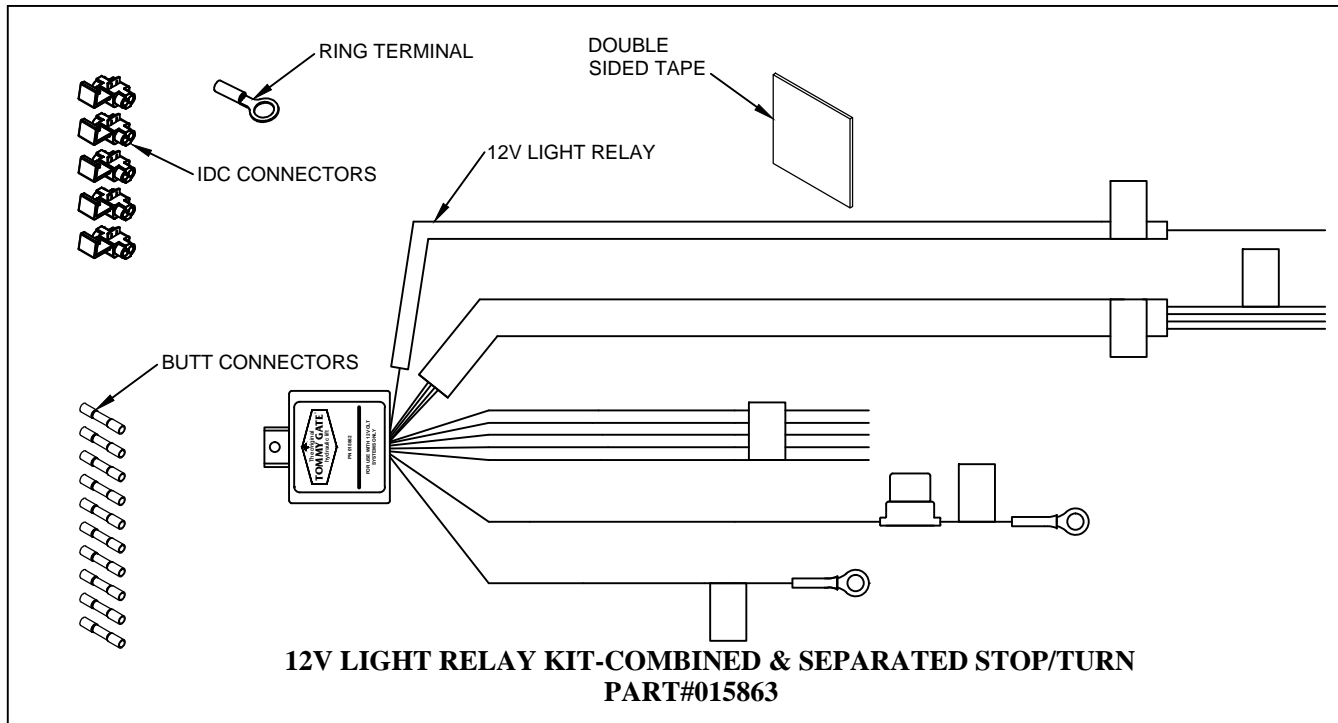

Figure 1: Part identification.

Table 1: Parts list.

QTY	PART NO.	DESCRIPTION
1	015862	12V LIGHT RELAY-COMBINED & SEPARATED STOP/TURN
10	009089	16-14 HEAT SHRINK BUTT CONNECTOR
5	015855	18-14 IDC WIRE CONNECTOR
1	013415	16-14 HEAT SHRINK 5/16" RING TERMINAL
1	015409	2"X2" DOUBLE SIDED FOAM TAPE

2. Lower the liftgate to the ground.

3. Disconnect power from the liftgate and vehicle by disconnecting the power cable from the positive side of the battery.

Note: If the liftgate's light harness is already connected to the vehicle's wiring without the relay, disconnect the liftgate's light harness from the vehicle's wiring.

4. Remove the fasteners holding the liftgate's mainframe box cover, and **Remove** the mainframe box cover.

5. **Select** a location in the liftgate's mainframe for the relay to be mounted. It must be mounted at a location that will allow the relay's positive (+) wire to reach the motor solenoid and allows the negative (-) wire to reach the ground bolt on the hydraulic pump (Figure 2). The relay must be kept clear of all moving components.

6. **Clean** the area that the relay will be mounted by removing any dirt/debris from the liftgate's mainframe.

7. **Secure** the relay to the selected location with the provided double sided foam tape, or carefully install a mounting screw if necessary. The epoxy side of the relay should be facing downward to prevent moisture accumulation (Figure 2).

8. **Locate** the vehicle's tail light harness or trailer tow harness.



Figure 2: Relay location (G2 series shown).

Note: For Ford trucks with smart trailer tow connector, use Table 2, Figure 3, and Figure 4 to locate the recommended wiring location.

Note: For all other makes and models, locate a suitable wiring location in either the vehicle's tail light harness or trailer tow harness (Figure 3 and Figure 4).

Table 2: Applications.

MAKE	YEAR	MODEL	CONFIGURATION	RECOMMENDED WIRING LOCATION
FORD	2019	RANGER	PICKUP BOX	TAIL LIGHT HARNESS NEAR TAIL LIGHT
			PICKUP BOX DELETE	TAIL LIGHT HARNESS ALONG FRAME
FORD	2015-2018	F-150	PICKUP BOX	TRAILER TOW HARNESS
			PICKUP BOX DELETE	TRAILER TOW HARNESS
FORD	2019	F-150	PICKUP BOX	TAIL LIGHT HARNESS NEAR TAIL LIGHT
			PICKUP BOX DELETE	TAIL LIGHT HARNESS ALONG FRAME
FORD	2016-2019	SUPER DUTY SERIES	PICKUP BOX	TAIL LIGHT HARNESS NEAR TAIL LIGHT
			PICKUP BOX DELETE/ CAB CHASSIS	TAIL LIGHT HARNESS ALONG FRAME

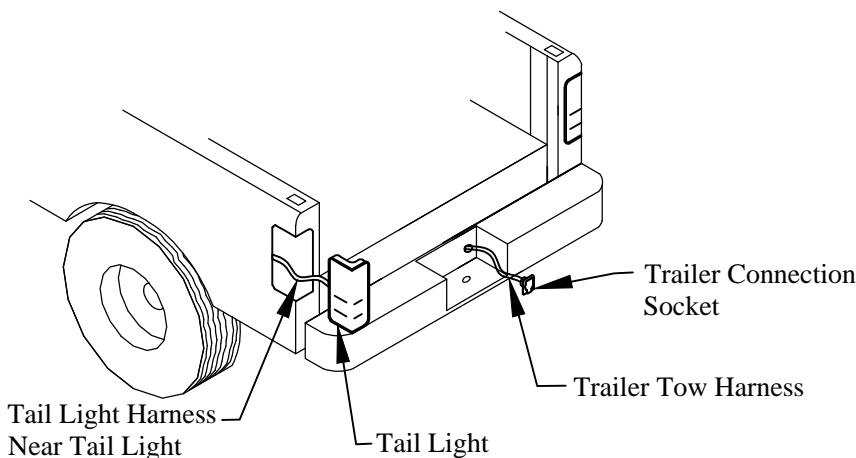

Figure 3: Relay wiring locations (Pickup Box).

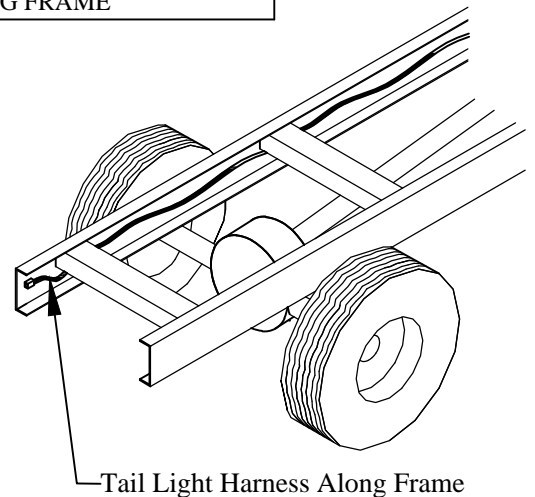

Figure 4: Relay wiring locations (Pickup Box Delete/Cab Chassis).

9. Identify the type of wiring system you will be connecting to:

Combined Stop/Turn (2-Wire) System- The vehicle's turn and stop functions are combined on one wire for each side, and the tail light function is on an additional wire. Trailer tow harnesses are usually this type of system.

Separated Stop/Turn (3-Wire) System- The vehicle's turn, stop, and tail light functions all use separate wires.

10. Skip to step 14 if the relay will be wired to a separated stop/turn (3-wire) tail light harness.

11. Remove the relay's red stop wire from the wire loom labeled "VEHICLE" (Figure 5).

12. Crimp the provided ring terminal to the relay's red stop wire.

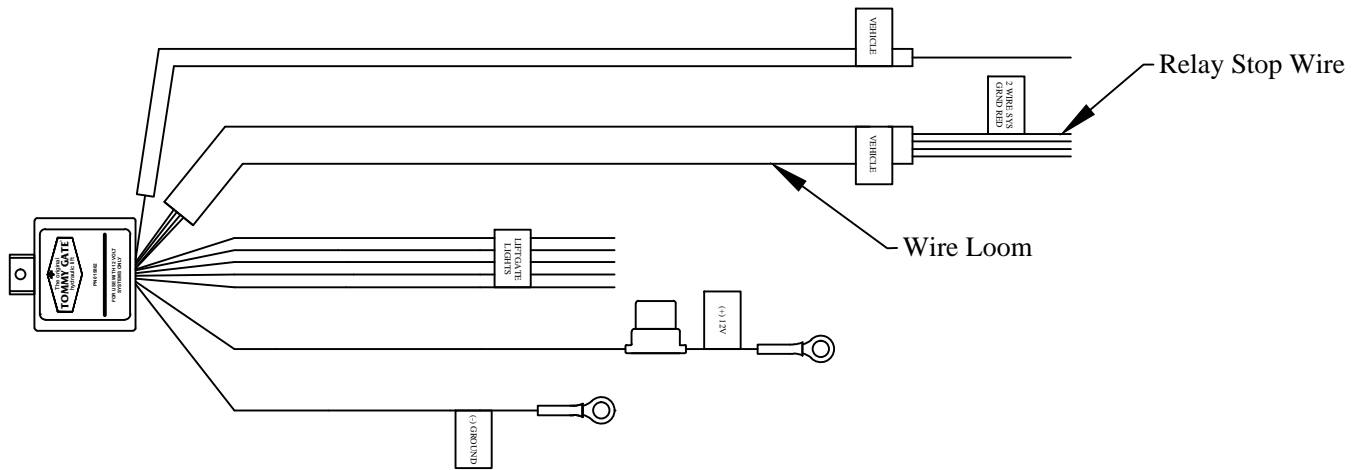

Figure 5: Locating relay stop wire.

13. Connect the relay's red stop wire to the ground bolt on the rear of the hydraulic pump if the relay will be wired to a combined stop/turn (2-wire) system (Figure 6).

Note: The liftgate's main ground cable and control ground wire are connected to this ground bolt.

14. Connect the relay's ground (-) wire to the ground bolt on the rear of the hydraulic pump (Figure 6 or Figure 7).

Note: The liftgate's main ground cable and control ground wire are connected to this ground bolt.

15. Route the relay's input wires, labeled "VEHICLE", through the rear of the liftgate's mainframe.

16. Connect the relay's input wires, labeled "VEHICLE", by splicing to the corresponding wires in the vehicle's tail light harness or trailer tow harness. Use the provided butt connectors or IDC connectors (Figure 6 or Figure 7).

17. Secure the relay's input wires to the vehicle using plastic zip ties or rubber-lined clips.

18. Connect the relay's five output wires, labeled "LIFTGATE LIGHTS", to the corresponding wires in the liftgate's light harness using the provided butt connectors (Figure 6 or Figure 7).

19. Connect the relay's positive (+) wire to the positive (+) supply terminal on the motor solenoid (Figure 6 or Figure 7).

Note: The liftgate's main power cable and control supply wire are connected to this stud.

20. **Verify** that the relay wiring matches the corresponding wiring diagram (Figure 6 or Figure 7).
21. **Install** the mainframe box cover and hardware on the liftgate.
22. **Connect** the power cable to the positive side of the battery.
23. **Verify** proper operation of lights.

Note: The liftgate's circuit breaker must be engaged for proper operation of light relay and liftgate lights.

Ford Technical Note

Ford trucks with smart trailer tow connector may display a trailer connected message on the dash when a trailer is not actually attached. This message may be a result of multiple conditions including:

- Additional lighting loads
- Corroded or faulty tow connector/socket (Ford TSB 18-2106)
- Added trailer tow harness extension

The trailer tow messaging feature may be turned off using a Ford IDS tool. See Ford Bulletin Q-242 for more information.

WIRING TO COMBINED STOP/TURN (2-WIRE) TAIL LIGHT HARNESS OR TRAILER TOW HARNESS

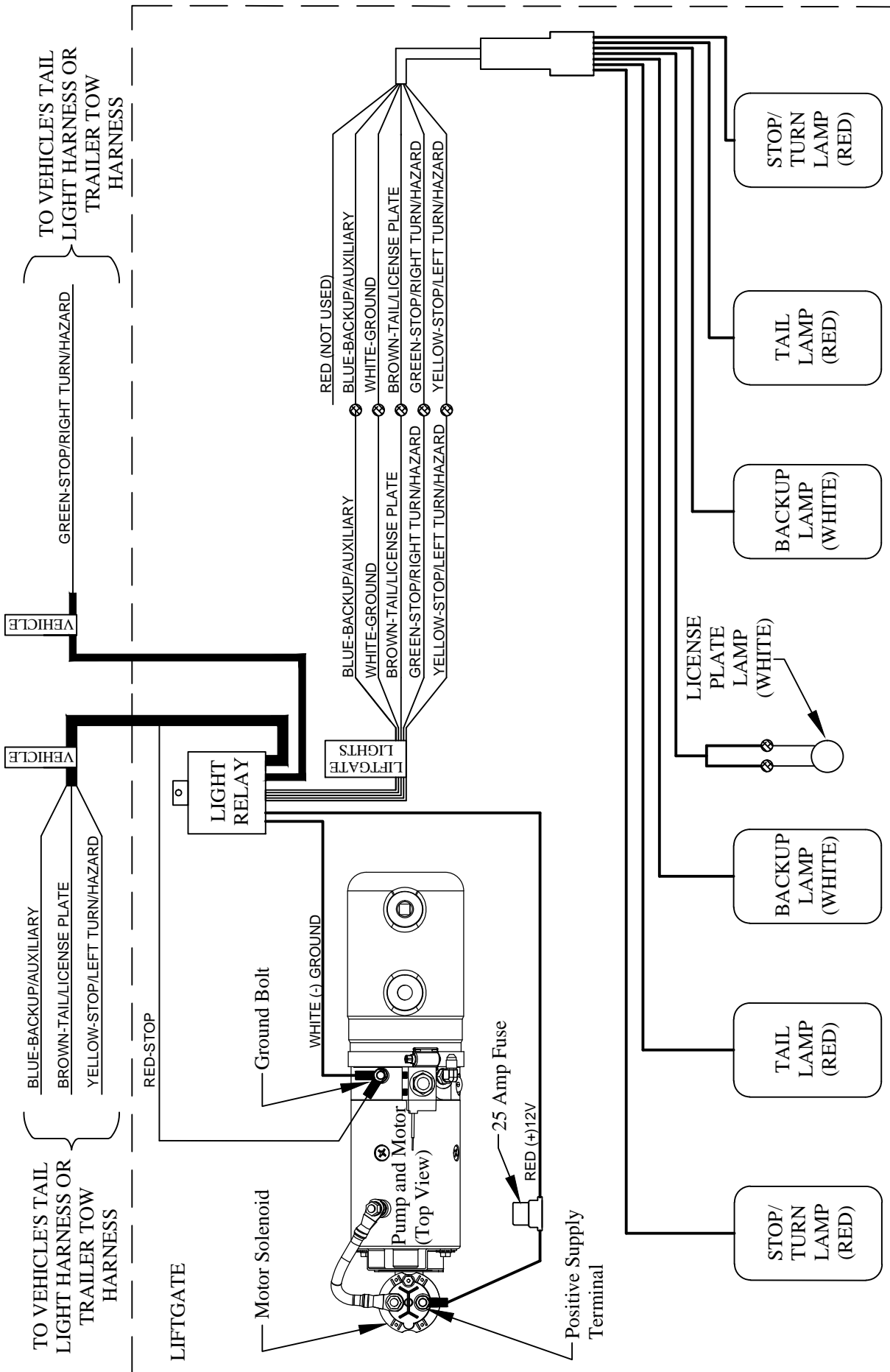

Figure 6: Wiring Diagram, Installing 015862 12V Light Relay on Vehicles with Combined Stop/Turn (2-Wire) Lighting Systems

- Notes:
1. ⊗ Symbol indicates usage of heat shrink butt connector.
 2. Control and battery wiring not shown for clarity.
 3. G2 series wiring shown, Original series similar.

WIRING TO SEPARATED STOP/TURN (3-WIRE) TAIL LIGHT HARNESS

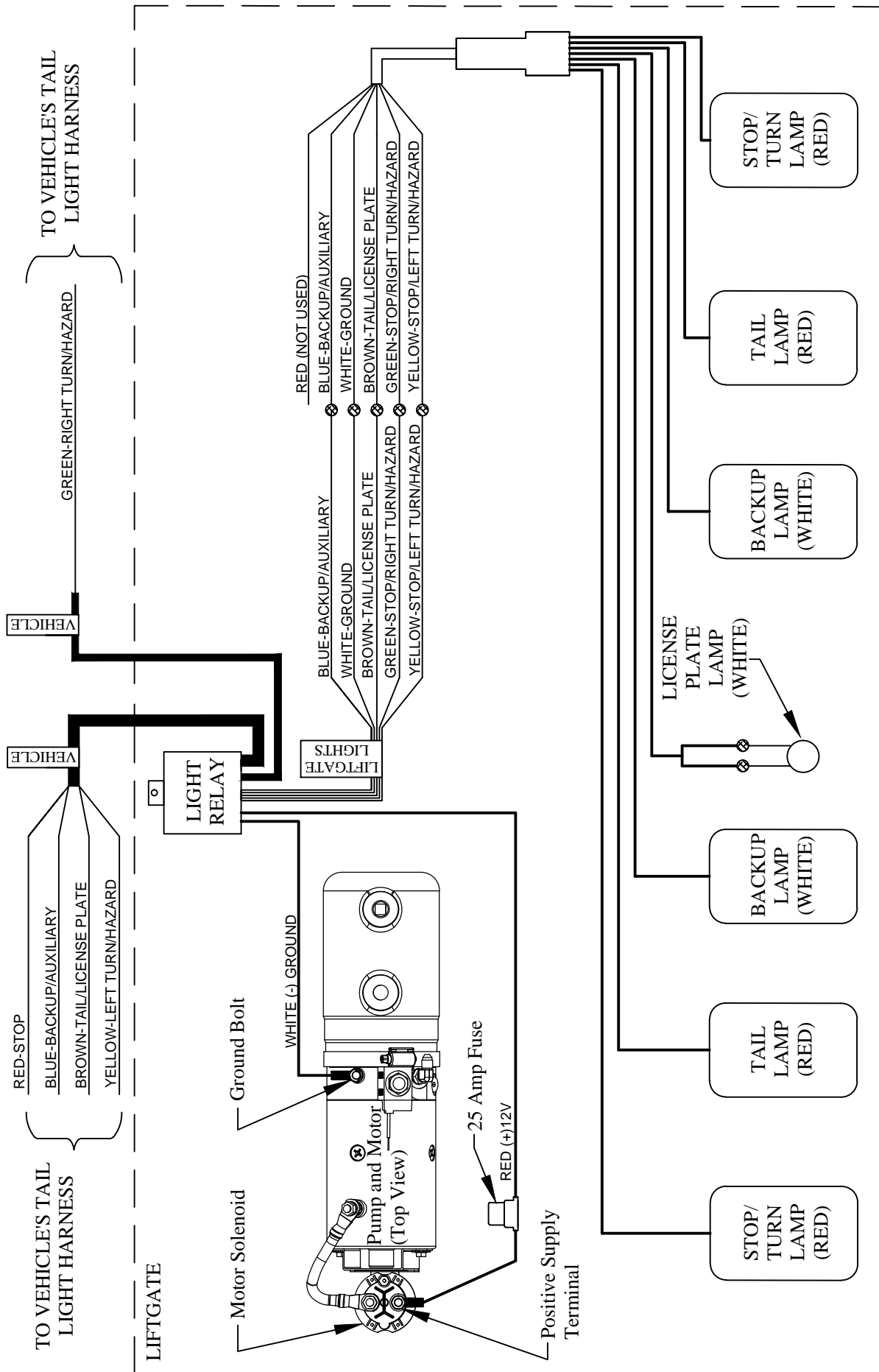

Figure 7: Wiring Diagram, Installing 015862 12V Light Relay on Vehicles with Separated Stop/Turn (3-Wire) Lighting Systems

- Notes:
- 1. ⊗ Symbol indicates usage of heat shrink butt connector.
 - 2. Control and battery wiring not shown for clarity.
 - 3. G2 series wiring shown, Original series similar.

WIRE ROUTING

- (1) When routing wires, avoid heat (above 180°F), abrasion, vibration, metal edges, screws, and trim fasteners. If such routings are not possible, protective devices must be used. If wires must cross a metal edge, the edge should be covered with a protective shield and the wiring fastened within 3 inches on each side of the edge.
- (2) Grommets must be used where wires pass through holes in sheet metal, castings, and / or frame rails. Do not bend wires in a radius smaller than 10 times the wire diameter.
- (3) Routing wires into areas exposed to wheel wash should be avoided. If this cannot be avoided protective shields are required to protect the wires from stones, ice, salt and water damage. Provide a drip loop to prevent moisture from being conducted into switches, relays, circuit breakers, and fuses.
- (4) Wires should be supported every 18 inches with plastic zip ties or rubber-lined clips.
- (5) Wires must be routed to clear moving parts by at least 3 inches unless positively fastened or protected by a conduit. If wiring must be routed between two members where relative motion can occur, the wiring should be secured to each member, with enough wire slack to allow flexing without damage to the wire.
- (6) Maintain at least a 6 inch clearance from exhaust system components. If this is not possible, high temperature insulation and heat shields are required. Existing OEM heat shields, insulation, and wire shielding must be maintained.
- (7) Do not route or attach electrical wires to fuel lines. Route electrical wires at least 1-1/2 inches away from the engine.

BATTERY, WIRE, TERMINALS, AND CONNECTORS

- (1) Wire attachments at the battery must be protected from tension loads so there is no undue strain on the battery terminals. Wires should be routed down rather than horizontally from the terminals with no sharp bends adjacent to the connections.
- (2) Battery power for your Tommy Gate should come directly from the battery or approved connection point through the supplied circuit breaker or fuse. The circuit breaker or fuse should be installed as close to the battery as possible.
- (3) Avoid splicing power cables. If splicing is necessary, the most durable splice joint will be bare metal barrel crimped, flow-soldered and covered with adhesive lined heat shrink tubing. Strip the wire ends making sure that individual conductor strands are not damaged. Use only rosin core solder, proper crimping tools, and wire with a gauge at least equivalent to the circuit being lengthened. Do not use electrical tape.
- (4) Battery cable terminals will be bare metal barrel crimped or flow-soldered and covered with adhesive lined heat shrink tubing.
- (5) Use wire connectors with locking features such as positive locking, inertia locking, bolt together, and soft mold-over with locking external retainers.

GENERAL

- (1) All frame contact areas must be wire brushed to bare metal, free of paint, dirt, and grease. Frame connections must be made using hardened flat washers under the bolt head and lock nuts. Corrosion preventive grease or compound is to be applied to the terminal area of the frame connection.
- (2) Frame cross members are not recommended as part of the ground return.
- (3) All circuit breakers and fuses should be located in one easily serviceable location with a means provided for identification of circuit function and current rating. Do not put circuit breakers or fuses in the vehicle cab.
- (4) Before welding to the chassis disconnect the battery. Also disconnect the power train, engine, valve, and transmission control modules.
- (5) Do not alter vehicle ignition, starting, and / or charging systems. Do not reroute engine compartment wiring.
- (6) Full copper circuitry and standardized polarity grounds are recommended.
- (7) Never increase the rating of a factory installed fuse or circuit breaker.
- (8) Disconnect the battery negative (ground) wire prior to any vehicle modification.

Following the above guidelines will provide you with years of trouble free service. Failing to incorporate the above guidelines may result in a voided warranty. Non-compliance with the guidelines above may result in a failure of electrical components, shutdown of engines, loss of backup brake systems, and the possibility of fire.

Q-242



SVE BULLETIN

SPECIAL VEHICLE ENGINEERING – BODY BUILDERS ADVISORY SERVICE

E-Mail via Website: www.fleet.ford.com/truckbbas (click "Contact Us")

Toll-free: (877) 840-4338

QVM Bulletin: Q-242

Date: 30 November, 2015

Trailer Tow Messaging and Aftermarket Body Lighting

Models Affected: F250–550 Chassis cab and Box Delete, and Box Removal Vehicles.

Description: 2016 MY Ford Super Duty vehicles have a trailer tow messaging feature that displays information about the trailer to the driver. All vehicles built before October 01, 2015 will have this feature enabled in the cluster. Using the trailer tow customer access circuits for second unit body or other lighting will cause a “trailer attached” and other trailer messages in the cluster.

All vehicles built before 10/01/15:

Vehicles Built before October 01, 2015 have this feature turned on in the cluster from the factory. Upfitters using the trailer tow circuits for body lighting on chassis cab, box delete, and box removable up fits will need to turn this feature off using an IDS tool. Refer to **SSM 45521** for procedure.

Incomplete vehicles built after 10/01/15:

Incomplete vehicle built after October 01, 2015 will have this feature turned off from factory.

Complete vehicles (pick-up box removal) built after 10/01/15:

Completed vehicles built after 10/08/15 will have this feature configured on. Upfitters removing the pick-up box of a completed vehicle and using the trailer tow circuits for utility body lighting will need to turn the feature off with an IDS tool. Refer to **SSM 45521** for procedure.

If you have any questions, please contact the Ford Truck Body Builders Advisory Service as shown in the header of this bulletin.