

ITEM NO.	QTY.	PART NO.	DESCRIPTION
1	1	012483	73 55+12 ALUMINUM SC PLATFORM COMPLETE(1P)
2	2	001936	SQ. TORSION SPRNG ARM (SC)
3	2	001910	.25"x1"x6.72" LINK
4	4	000510	3/8-16x1-1/4" HHCS GR5
5	4	000575	3/8 USS FLAT WASHER
6	4	001906	.377" I.D.X.503" O.D.X.281" BRONZE BUSHING
7	6	000553	3/8-16 LARGE FLANGE LOCK NUT
8	2	001914	0.115"WIREX0.75"x5.5" EX. SPRING
9	1	002031	0.75" SQ.X74.63" PIVOT BAR
10	4	000582	1-1/2" NARROW RIM MACHINE BUSHING
11	2	004720	1/4"x2" COTTER PIN
12	1	001942	.88" I.D.x1.12" O.D.x76.5" TUBE ASY (73)
13	2	005037	7/8" HEYCO PLUG
14	2	001902	1/2" DIA.x1-1/2" CHROME PLATED SHOULDER BOLT
15	1	007282	SELF CLOSE ARM (LEFT) (N)
16	1	007281	SELF CLOSE ARM (RIGHT) (N)

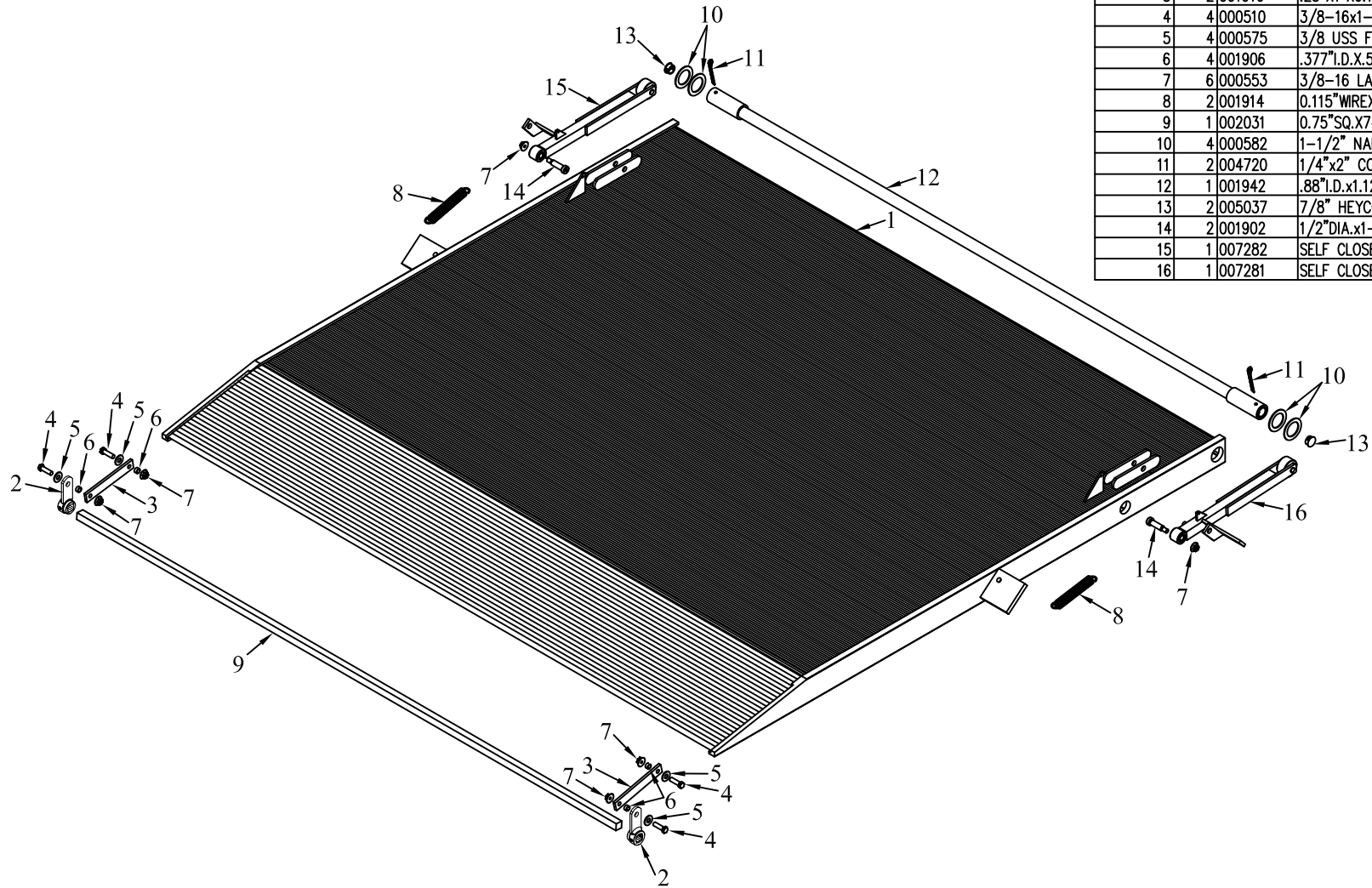

REV.	DATE	CHANGE RECORD	BY	APPVD	ECN	THIRD ANGLE PROJECTION	FILENAME:	SYMBOLY PER ANSI Y14.5	NOTES:	WOODBINE MFG. CO. BUS BROWN DRIVE WOODBINE, IOWA 51579 712-647-2050																														
C	1/3/13	REPLACED (1) 9144 W/ (1) 12483	GDB		805	<table border="1"> <tr> <td>DECIMAL</td> <td>2PLC</td> <td>3PLC</td> </tr> <tr> <td>MACHINE SAW, DRILL</td> <td>.030</td> <td>.015</td> </tr> <tr> <td>SHEAR, PUNCH FORM</td> <td>.060</td> <td>.030</td> </tr> <tr> <td>TORCH, WELDING ROUGH CAST</td> <td>.090</td> <td>.060</td> </tr> <tr> <td>DRAFT 2°</td> <td>ANGULAR ±1°</td> <td></td> </tr> </table>	DECIMAL	2PLC	3PLC	MACHINE SAW, DRILL	.030	.015	SHEAR, PUNCH FORM	.060	.030	TORCH, WELDING ROUGH CAST	.090	.060	DRAFT 2°	ANGULAR ±1°		<table border="1"> <tr> <td>DRAWN BY:</td> <td>JCB</td> </tr> <tr> <td>DRAWN/DATE</td> <td>8/15/08</td> </tr> <tr> <td>APPVD/DATE</td> <td></td> </tr> <tr> <td>SALES CATEGORY</td> <td></td> </tr> </table>	DRAWN BY:	JCB	DRAWN/DATE	8/15/08	APPVD/DATE		SALES CATEGORY		<table border="1"> <tr> <td>PRODUCT LINE</td> <td>SCALE</td> <td>FIN. WT.</td> <td>PART NO.</td> </tr> <tr> <td></td> <td>1:16</td> <td></td> <td>6374</td> </tr> </table>	PRODUCT LINE	SCALE	FIN. WT.	PART NO.		1:16		6374	<p>THE INFORMATION HERE IS CONFIDENTIAL AND MUST NOT BE USED IN ANYWAY DETRIMENTAL TO THE INTEREST OF WOODBINE MFG.</p> <p>The original TOMMY GATE hydraulic lift</p>
DECIMAL	2PLC	3PLC																																						
MACHINE SAW, DRILL	.030	.015																																						
SHEAR, PUNCH FORM	.060	.030																																						
TORCH, WELDING ROUGH CAST	.090	.060																																						
DRAFT 2°	ANGULAR ±1°																																							
DRAWN BY:	JCB																																							
DRAWN/DATE	8/15/08																																							
APPVD/DATE																																								
SALES CATEGORY																																								
PRODUCT LINE	SCALE	FIN. WT.	PART NO.																																					
	1:16		6374																																					
B	5/2/12	REMOVED (4) 007711	GDB		649																																			
A	8/15/08	DRAWN IN AUTOCAD	JCB	KGJ																																				