

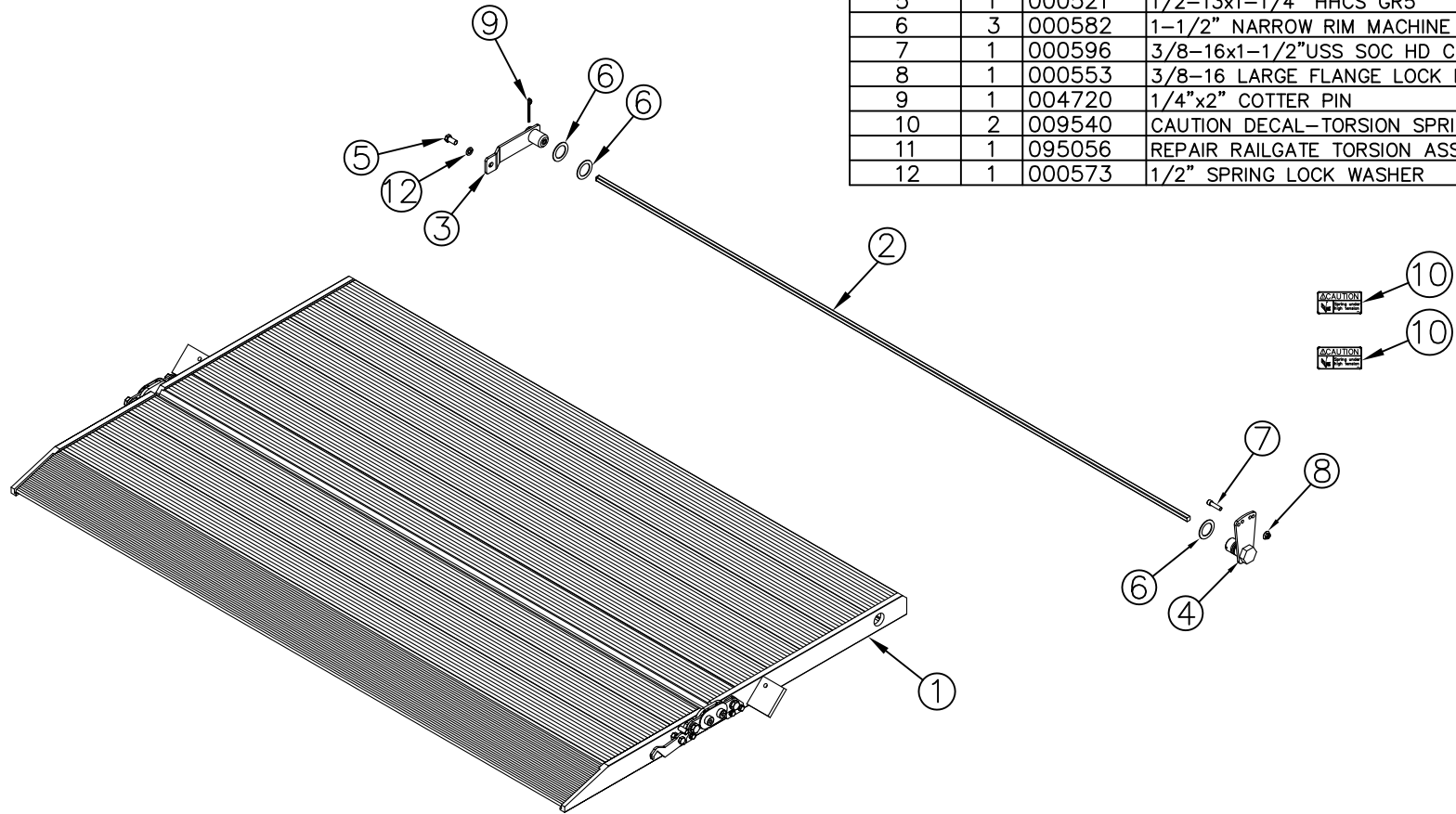
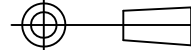

ITEM NO.	QTY.	PART NO.	DESCRIPTION
1	1	004122	89 30+15+6 ALUMINUM R-FOLD PLATFORM COMP.
2	1	005232	1/2"SQ.X90-3/4" RAIL TORSION SPRING(89)
3	1	012674	TORSION ARM RAIL (DR) 1/2 SQ ZINC PLATED
4	1	007265	1/2" RAIL TORSION SPRING HOLDER(PAS) ZINC
5	1	000521	1/2-13x1-1/4" HHCS GR5
6	3	000582	1-1/2" NARROW RIM MACHINE BUSHING
7	1	000596	3/8-16x1-1/2"USS SOC HD CAP
8	1	000553	3/8-16 LARGE FLANGE LOCK NUT
9	1	004720	1/4"x2" COTTER PIN
10	2	009540	CAUTION DECAL-TORSION SPRING
11	1	095056	REPAIR RAILGATE TORSION ASSIST SPRING INSTR.
12	1	000573	1/2" SPRING LOCK WASHER



REV.	DATE	CHANGE RECORD	BY	APPVD	ECN	DRAFT	ANGULAR	SALES CATEGORY	PRODUCT LINE	SCALE	FIN. WT.	PART NO.																							
E	1/7/13	12674 WAS 7767, 521 WAS 736, ADDED (1) 573, ADDED (1) 582	GDB		805	THIRD ANGLE PROJECTION		FILENAME:	WOODBINE MFG. CO. BUS BROWN DRIVE WOODBINE, IOWA 51579 712-647-2050  THE INFORMATION HERE IS CONFIDENTIAL AND MUST NOT BE USED IN ANYWAY DETRIMENTAL TO THE INTEREST OF WOODBINE MFG.																										
D	3/24/11	REPLACED 6238 WITH 7767	JCB		426			SYMBOLY PER ANSI Y14.5					NOTES: _____ _____ _____ _____ _____																						
C	4/26/10	REPLACED TORSION SPRING KIT WITH INDIVIDUAL PARTS	JCB		293	<table border="1"> <tr> <th>DECIMAL</th> <th>2PLC</th> <th>3PLC</th> </tr> <tr> <td>MACHINE SAW, DRILL</td> <td>.030</td> <td>.015</td> </tr> <tr> <td>SHEAR, PUNCH FORM</td> <td>.060</td> <td>.030</td> </tr> <tr> <td>TORCH, WELDING ROUGH CAST</td> <td>.090</td> <td>.060</td> </tr> </table>	DECIMAL	2PLC									3PLC	MACHINE SAW, DRILL	.030	.015	SHEAR, PUNCH FORM	.060	.030	TORCH, WELDING ROUGH CAST	.090	.060	<table border="1"> <tr> <td>DRAWN BY.</td> <td rowspan="3">8/19/08</td> </tr> <tr> <td>JCB</td> </tr> <tr> <td>DRAWN/DATE</td> </tr> <tr> <td>APPVD/DATE</td> <td>TITLE</td> </tr> <tr> <td></td> <td>REPLACEMENT 89 30+15+6 ALUMINUM R-FOLD PLAT. COMP.</td> </tr> </table>	DRAWN BY.	8/19/08	JCB	DRAWN/DATE	APPVD/DATE	TITLE		REPLACEMENT 89 30+15+6 ALUMINUM R-FOLD PLAT. COMP.
DECIMAL	2PLC	3PLC																																	
MACHINE SAW, DRILL	.030	.015																																	
SHEAR, PUNCH FORM	.060	.030																																	
TORCH, WELDING ROUGH CAST	.090	.060																																	
DRAWN BY.	8/19/08																																		
JCB																																			
DRAWN/DATE																																			
APPVD/DATE	TITLE																																		
	REPLACEMENT 89 30+15+6 ALUMINUM R-FOLD PLAT. COMP.																																		
B	5/19/09	UPDATED GRAPHIC AND WEIGHT	JCB	JCB																															
A	8/19/08	DRAWN IN AUTOCAD	JCB	KGJ																															
						DRAFT 2'	ANGULAR ±1'			1:20	227.1	6448																							