



**NEW PRODUCT**



\*Product Rendering is for illustrative purposes only. Actual liftgates ship with complete safety decals.

## THE ALL-NEW ***G2 LIFT-N-DUMP.***

Tommy Gate's G2 Liftgate Series has expanded. Due to popular demand, our Lift-N-Dump model is now available with a dual-drive system. Like all G2 Series lifts, the new G2 Lift-N-Dump features dual hydraulic cylinders, one on each side of the platform, ensuring a stable, even and smooth lift for your cargo. And with 1600 lbs. capacity, 50" of vertical travel and newly designed platform latches, this G2 model is sure to satisfy those looking for the most powerful and reliable Dump Body liftgate available.



Every Tommy Gate is proudly made in Woodbine, Iowa, USA.

# FEATURES

- **1** Dual hydraulic cylinders ensure a stable and even lift for cargo
- **2** The newly designed G2 Lift-N-Dump latch offers simple, lockable operation
- 1600 lbs lifting capacity
- 6" Taper
- 150 Amp circuit breaker with manual reset helps protect the electrical system
- The full-length molded ground and power cable provides a direct connection from the liftgate to the truck battery, ensuring solid electrical connections
- Hard-chrome pins and composite bushings at major pivot points in the platform
- Optional rubber bumpers provide a rubber cushion between the platform and the ground surface
- Light Kit: G2 Recessed Light Kit (3-light kit; works with 2 or 3 light systems)
- LED Light Kit: G2 Recessed Light Kit (3-light kit; works with 2 or 3 light systems)
- Curb side fixed control
- Optional Pendant control
- Operator friendly dump lever
- Box cover can be removed w/ gate up or down
- Torsion assist bar assists in closing the platform
- Drop chain covers provide a quieter ride
- Full-size pump & motor
- Pressure relief prevents operator from overloading the platform
- Flow Control Valve prevents uncontrolled descent of platform

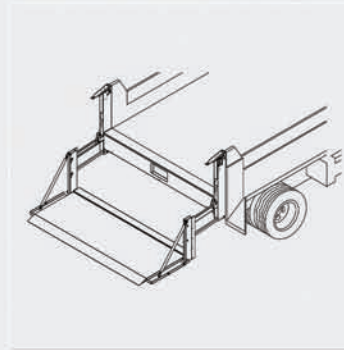

\*Product Rendering is for illustrative purposes only. Actual liftgates ship with complete safety decals.

# SPECS



Model	Capacity (lbs.)	Vertical Travel	Outside Width	Opening Width	Platform Loadable Area (WxD)	Taper	Application Code*	Dual Cylinders	Platform	Weight (lbs)
G2-73-1650 LD	1600	50	73	67	64x34	6	A,E,F	✓	Treadplate	592
G2-81-1650 LD	1600	50	81	76	73x34	6	B,E,F	✓	Treadplate	634
G2-87-1650 LD	1600	50	87	81	78x34	6	C,E,F	✓	Treadplate	659
G2-92-1650 LD	1600	50	92	86	83x34	6	D,E,F	✓	Treadplate	682

## \* Application Codes

A.	Dump Body	64" to 69"
B.	Dump Body	69" to 78"
C.	Dump Body	78" to 83"
D.	Dump Body	83" to 88"
E.	Box Dump w/ Double Acting Hoist	
F.	Platform Dump w/ Double Acting Hoist	

## Notes:

All measurements in inches, unless noted  
WxD = Width x Depth

## Warranty:

Tommy Gate's G2 dual drive liftgates have a warranty for two years from date of purchase.

Before Installing any Lift Gate, please observe the Vehicle Loading Limitations. These loading limitations are outlined in the Vehicle Owner's Manual and the Safety Compliance Certification label located on the driver's door pillar.

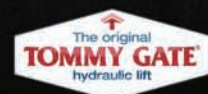

1-800-LIFTGATE (1-800-543-8428)

Fax (712) 647-2417  
info@tommygate.com

1210 Lincoln Way  
Woodbine, IA 51579

Use of a double-acting hoist is recommended.  
Using a single-acting hoist requires tie-down clamps.

