

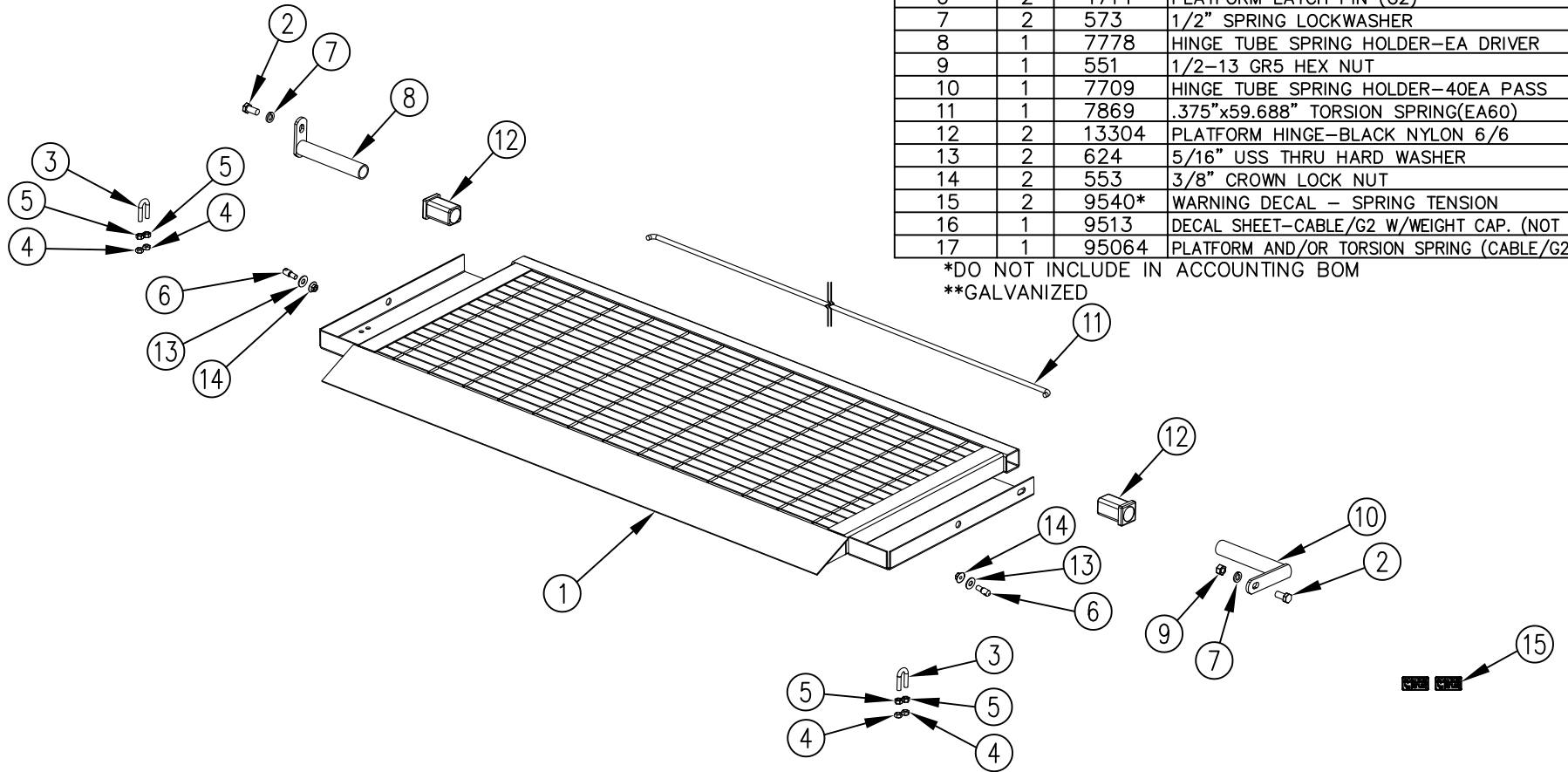

ITEM NO.	QTY.	PART NO.	DESCRIPTION
1	1	6197**	G2 60-42 22+4" BG PLATFORM COMPLETE
2	2	587	1/2-13x1" HHCS GR5
3	2	4727	3/8"U-BOLT(SHORT)x16x7/8x1-1/2
4	4	605	3/8-16 USS CROWN LOCK NUT
5	4	550	3/8-16 GR5 HEX NUT
6	2	4714	PLATFORM LATCH PIN (G2)
7	2	573	1/2" SPRING LOCKWASHER
8	1	7778	HINGE TUBE SPRING HOLDER-EA DRIVER
9	1	551	1/2-13 GR5 HEX NUT
10	1	7709	HINGE TUBE SPRING HOLDER-40EA PASS
11	1	7869	.375"x59.688" TORSION SPRING(EA60)
12	2	13304	PLATFORM HINGE-BLACK NYLON 6/6
13	2	624	5/16" USS THRU HARD WASHER
14	2	553	3/8" CROWN LOCK NUT
15	2	9540*	WARNING DECAL - SPRING TENSION
16	1	9513	DECAL SHEET-CABLE/G2 W/WEIGHT CAP. (NOT SHOWN)
17	1	95064	PLATFORM AND/OR TORSION SPRING (CABLE/G2) INSTR.



*DO NOT INCLUDE IN ACCOUNTING BOM
 **GALVANIZED

NOTES: APPLY DECALS FROM 9513 SHEET SAME AS PRODUCTION
 SEND (2) 9540 LOOSE

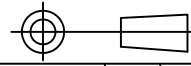
				THIRD ANGLE PROJECTION			FILENAME:		WOODBINE MFG. CO. BUS BROWN DRIVE WOODBINE, IOWA 51579  THE INFORMATION HERE IS CONFIDENTIAL AND MUST NOT BE USED IN ANYWAY DETRIMENTAL TO THE INTEREST OF WOODBINE MFG.													
							SYMBOLY PER ANSI Y14.5															
				<table border="1"> <thead> <tr> <th>DECIMAL</th> <th>2PLC</th> <th>3PLC</th> </tr> </thead> <tbody> <tr> <td>MACHINE SAW, DRILL</td> <td>.030</td> <td>.015</td> </tr> <tr> <td>SHEAR, PUNCH FORM</td> <td>.060</td> <td>.030</td> </tr> <tr> <td>TORCH, WELDING ROUGH CAST</td> <td>.090</td> <td>.060</td> </tr> </tbody> </table>			DECIMAL	2PLC			3PLC	MACHINE SAW, DRILL	.030	.015	SHEAR, PUNCH FORM	.060	.030	TORCH, WELDING ROUGH CAST	.090	.060	DRAWN BY: AAS	
DECIMAL	2PLC	3PLC																				
MACHINE SAW, DRILL	.030	.015																				
SHEAR, PUNCH FORM	.060	.030																				
TORCH, WELDING ROUGH CAST	.090	.060																				
							DRAWN/DATE 9/6/24															
A	9/6/24	RELEASED TO PRODUCTION		AAS		3051	TITLE G2 60 27+0+4 BG REPLACEMENT PLATFORM GALVANIZED															
REV.	DATE	CHANGE RECORD		BY	APPVD	ECN	DRAFT 2"	ANGULAR ±1"	SCALE 1:14	FIN. WT.	PART NO. 18323											