

ITEM NO.	QTY.	PART NO.	DESCRIPTION
1	1	012821	50" EA TU PLATFORM W/CARTSTOP
2	12	000576	1/2" USS FLAT WASHER
3	14	000573	1/2" SPRING LOCK WASHER
4	6	009023	2" LARGE BLACK PLUG
5	2	009506	DECAL SHEET-RAILGATE
6	12	000587	1/2-13x1" HHCS GR5
7	1	095195	TKT EA PLATFORM REPLACEMENT INSTRUCTIONS

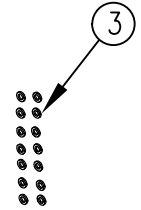
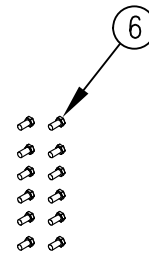
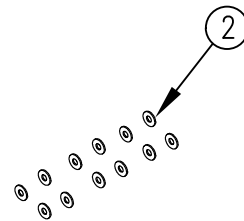
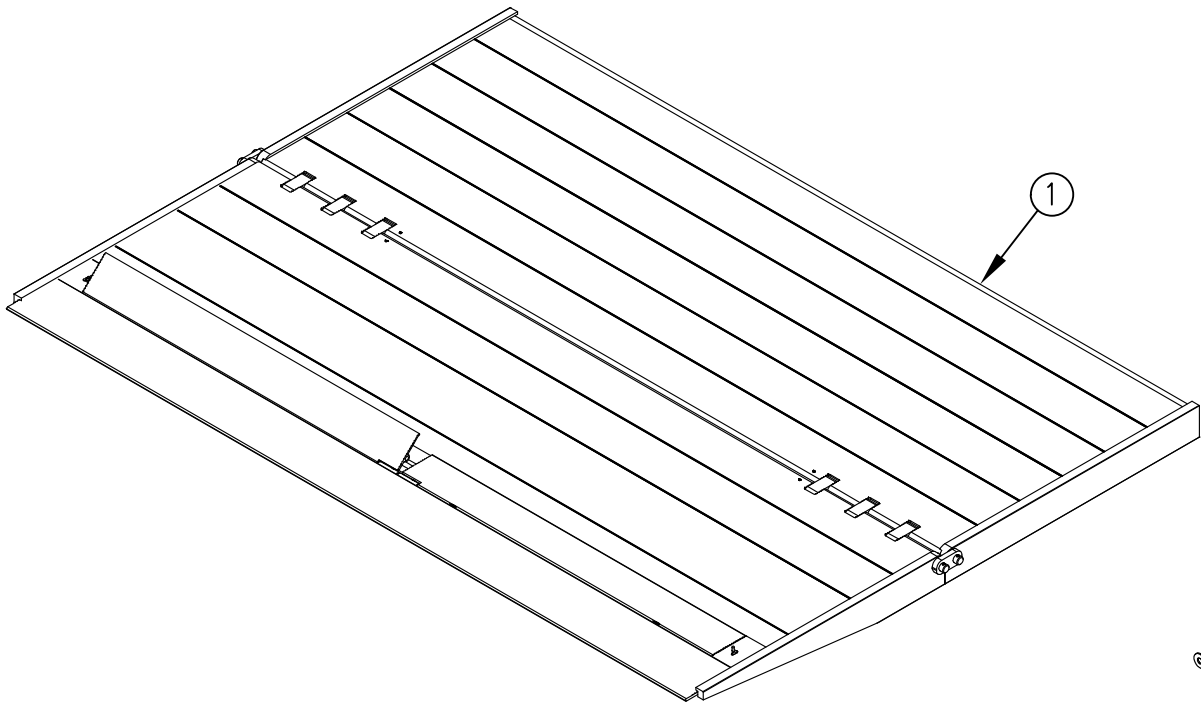
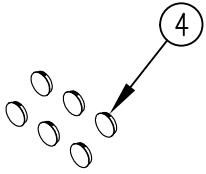

NOTE: APPLY DECALS FROM 9506 SHEETS SAME AS PRODUCTION

D	3/16/16	UPDATED BOM TO MATCH PRODUCTION	GDB	1600	THIRD ANGLE PROJECTION 	FILENAME:				WOODBINE MFG. CO. BUS BROWN DRIVE WOODBINE, IOWA 51579					
C	12/31/15	REMOVED 13049, 13697, AND 13057, 509 WAS 11524	GDB	1548		DECIMAL	2PLC	3PLC	SYMBOLGY PER ANSI Y14.5				NOTES: 		
B.1	3/25/15	BILL CORRECTIONS TO MATCH PRODUCTION	GDB		MACHINE SAW, DRILL	.030	.015	DRAWN BY: JCB				THE INFORMATION HERE IS CONFIDENTIAL AND MUST NOT BE USED IN ANYWAY DETRIMENTAL TO THE INTEREST OF WOODBINE MFG.			
B	3/20/15	ADDED 095168, AND (2) 011527, 013049 WAS 011615	GDB	1348	SHEAR, PUNCH FORM	.060	.030	DRAWN/DATE 5/20/14							
A	5/20/14	RELEASED TO PRODUCTION	JCB	1075	TORCH, WELDING ROUGH CAST	.090	.060	APPVD/DATE				SALES CATEGORY			
REV.	DATE	CHANGE RECORD	BY	APPVD	ECN	DRAFT 2'	ANGULAR ±1'	PRODUCT LINE							