

TKL LED Light Kit Mounting Instructions

Note: This LED Light Kit is designed for 12-volt vehicles with combined Stop/Tail/Turn/Reverse combined functions.

1. Verify LED Light Kit (Figure 1 and Table 1).

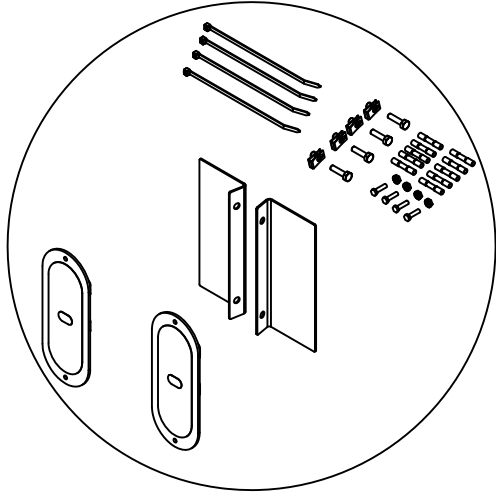

Figure 1: LED Light Kit.

Table 1: Parts list for kit PN015887

QTY.	PART NO.	DESCRIPTION
2	015811	Stop/Tail/Turn/Reverse Combination LED
2	015653	TKL LED Protector
4	010827	1/4-20 Extruded "U" Nut
4	014518	1/4-20x1" HHCS GR5 Bolt
4	009077	3/16"x7-1/2" Cable Tie
4	001485	10-32x3/4 Bolt
4	000556	10-32 KEPS Nut
10	009089	Butt Connector

2. Lower the liftgate to the ground (liftgate now shown). To avoid a risk of a 12 volt electrical short, disconnect the #4 power cable from the positive side of the battery or manually trip the circuit breaker (Figure 2).

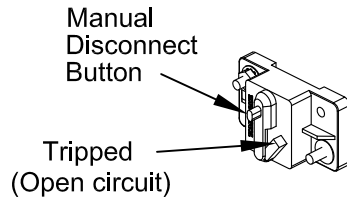

Figure 2: Circuit breaker.

3. Remove the cover plate by taking out the two (2) 1/4" hex head bolts on each side with a 3/8" wrench or socket (Figure 3).

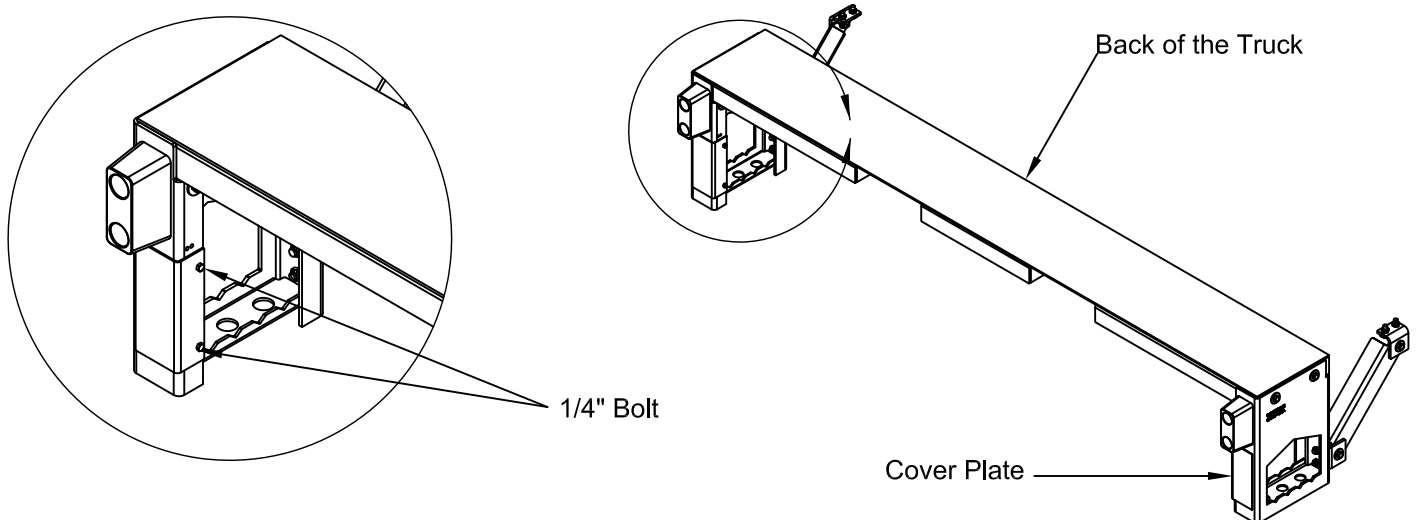

Figure 3: Cover plate location.

TKL LED Light Kit Mounting Instructions

4. Bolt the light inside the side step with the provided two (2) 10-32 bolts and 10-32 keps nuts (Figure 4).

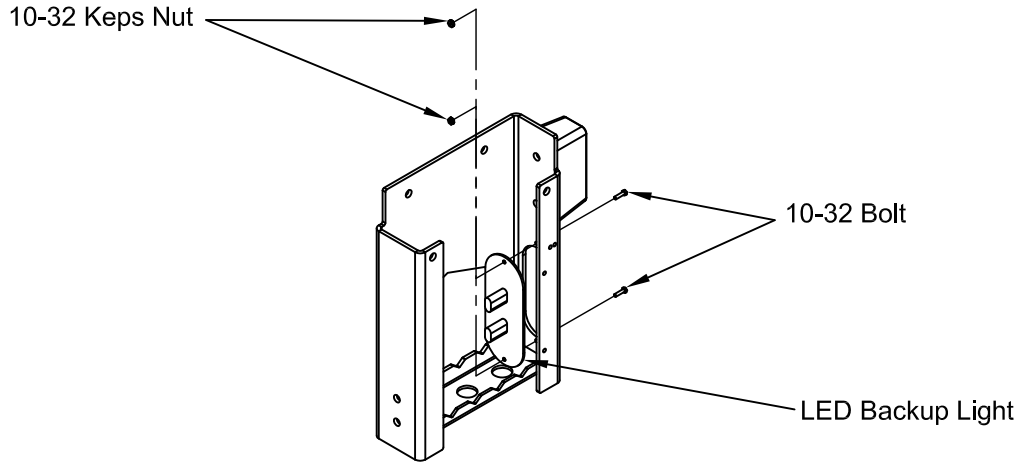

Figure 4: Light location.

5. Locate two 3/8" holes in the rear of the bed extension. Use to route the truck light harness. It might be needed to drill a new hole on the back of the truck (Figure 5).

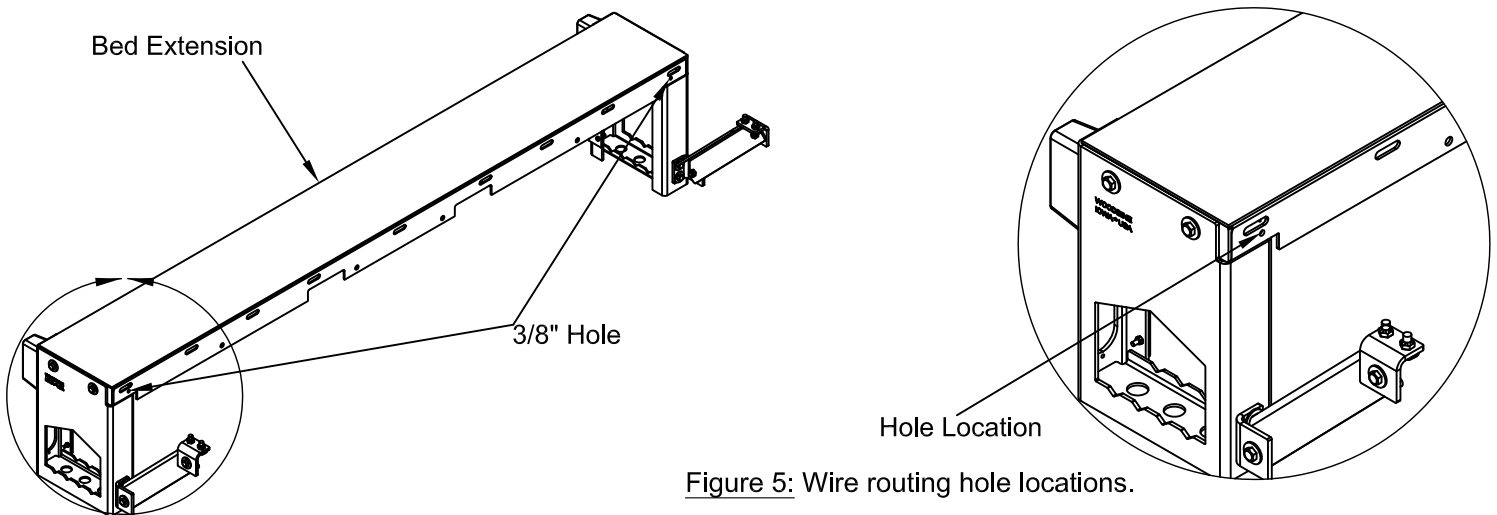
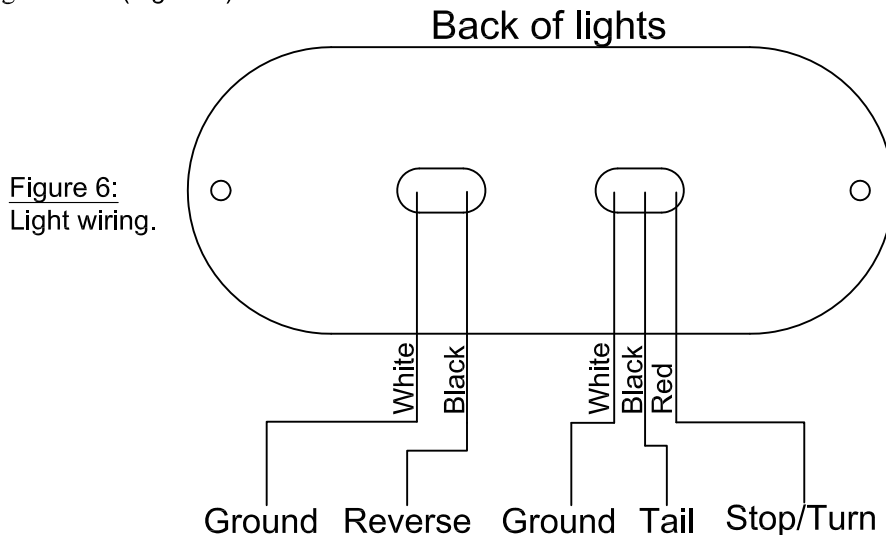

Figure 5: Wire routing hole locations.

NOTE: Before connecting the light to the truck harness, make sure to route the harness through the back holes of the bed extension. Making sure that no wires are pinched between the bed extension and the liftgate.

6. Connect the light to the vehicle according to the wiring diagram for the system that you are using. Follow the recommended electrical guidelines (Figure 6).



TKL LED Light Kit Mounting Instructions

7. Zip tie the wiring inside the bed extension, using provided holes (Figure 7).

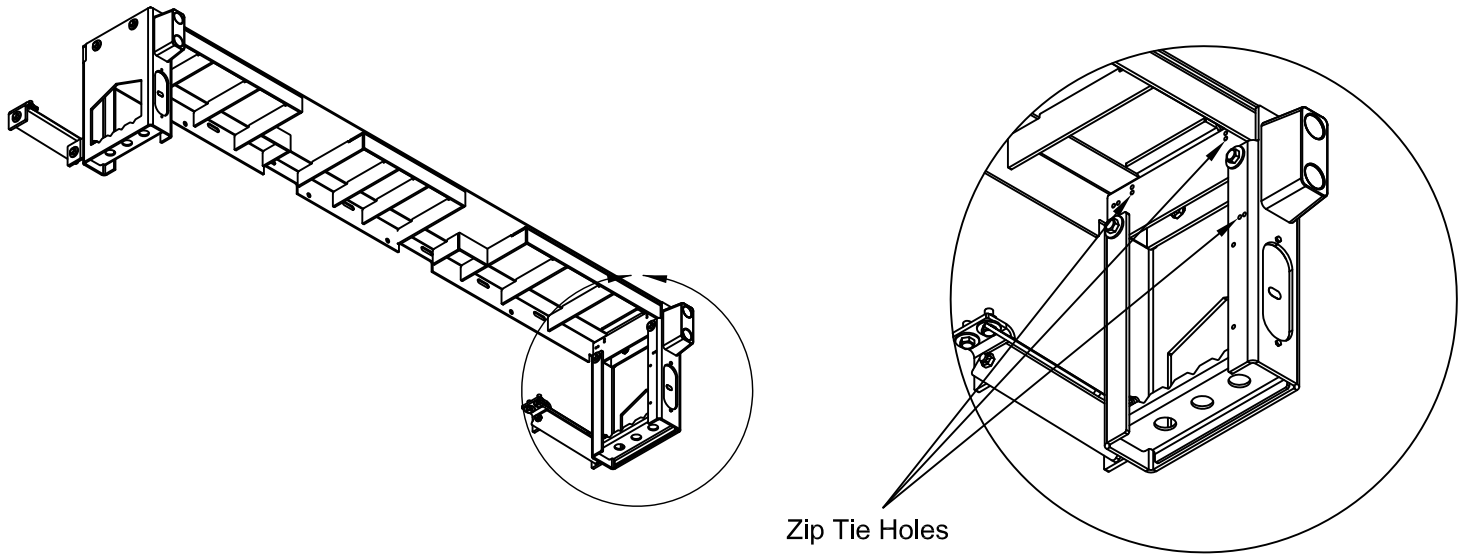

Figure 7: Zip tie locations.

8. Check for proper operation of lights.

9. Place "U" nuts over bent flange on LED protector plate (Figure 8).

9. Bolt the LED Protector plate on the same holes where the cover plate was originally installed with the provided two (2) 1/4"x1" bolts and two (2) 1/4" "U" nuts (Figure 8).

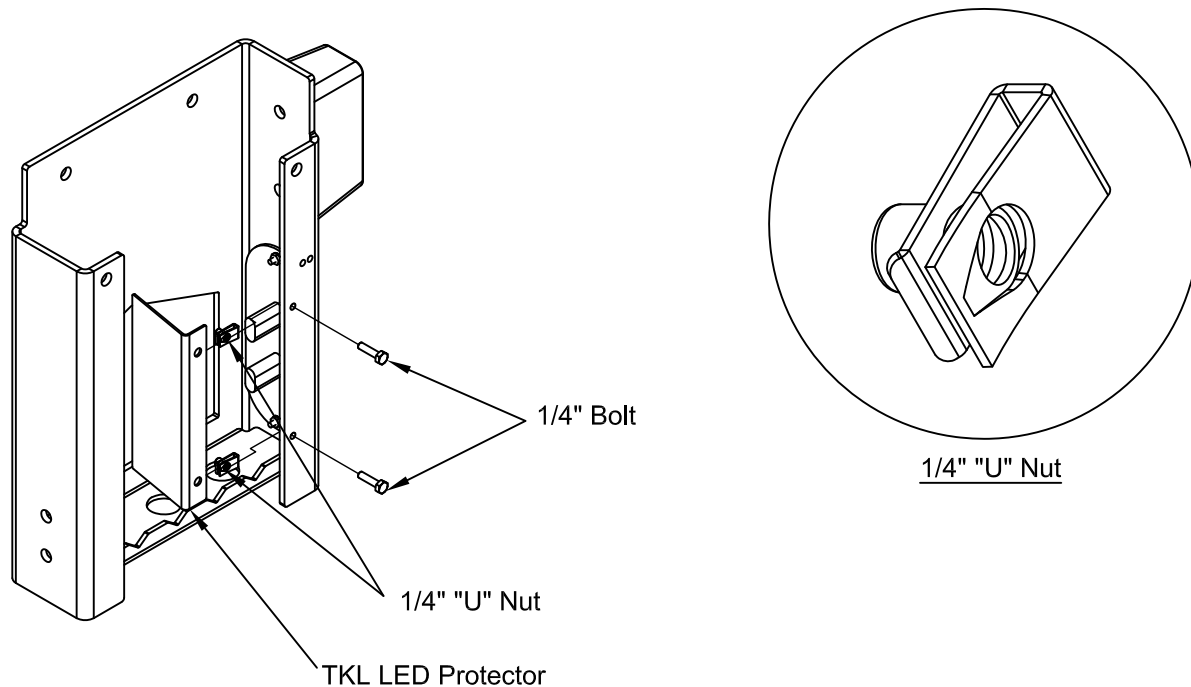

Figure 8

WIRE ROUTING

- (1) When routing wires, avoid heat (above 180°F), abrasion, vibration, metal edges, screws, and trim fasteners. If such routings are not possible, protective devices must be used. If wires must cross a metal edge, the edge should be covered with a protective shield and the wiring fastened within 3 inches on each side of the edge.
- (2) Grommets must be used where wires pass through holes in sheet metal, castings, and / or frame rails. Do not bend wires in a radius smaller than 10 times the wire diameter.
- (3) Routing wires into areas exposed to wheel wash should be avoided. If this cannot be avoided protective shields are required to protect the wires from stones, ice, salt and water damage. Provide a drip loop to prevent moisture from being conducted into switches, relays, circuit breakers, and fuses.
- (4) Wires should be supported every 18 inches with plastic zip ties or rubber-lined clips.
- (5) Wires must be routed to clear moving parts by at least 3 inches unless positively fastened or protected by a conduit. If wiring must be routed between two members where relative motion can occur, the wiring should be secured to each member, with enough wire slack to allow flexing without damage to the wire.
- (6) Maintain at least a 6 inch clearance from exhaust system components. If this is not possible, high temperature insulation and heat shields are required. Existing OEM heat shields, insulation, and wire shielding must be maintained.
- (7) Do not route or attach electrical wires to fuel lines. Route electrical wires at least 1-1/2 inches away from the engine.

BATTERY, WIRE, TERMINALS, AND CONNECTORS

- (1) Wire attachments at the battery must be protected from tension loads so there is no undue strain on the battery terminals. Wires should be routed down rather than horizontally from the terminals with no sharp bends adjacent to the connections.
- (2) Battery power for your Tommy Gate should come directly from the battery or approved connection point through the supplied circuit breaker or fuse. The circuit breaker or fuse should be installed as close to the battery as possible.
- (3) Avoid splicing power cables. If splicing is necessary, the most durable splice joint will be bare metal barrel crimped, flow-soldered and covered with adhesive lined heat shrink tubing. Strip the wire ends making sure that individual conductor strands are not damaged. Use only rosin core solder, proper crimping tools, and wire with a gauge at least equivalent to the circuit being lengthened. Do not use electrical tape.
- (4) Battery cable terminals will be bare metal barrel crimped or flow-soldered and covered with adhesive lined heat shrink tubing.
- (5) Use wire connectors with locking features such as positive locking, inertia locking, bolt together, and soft mold-over with locking external retainers.

GENERAL

- (1) All frame contact areas must be wire brushed to bare metal, free of paint, dirt, and grease. Frame connections must be made using hardened flat washers under the bolt head and lock nuts. Corrosion preventive grease or compound is to be applied to the terminal area of the frame connection.
- (2) Frame cross members are not recommended as part of the ground return.
- (3) All circuit breakers and fuses should be located in one easily serviceable location with a means provided for identification of circuit function and current rating. If possible, avoid putting circuit breakers or fuses in the vehicle cab.
- (4) Before welding to the chassis disconnect the battery. Also disconnect the power train, engine, valve, and transmission control modules.
- (5) Do not alter vehicle ignition, starting, and / or charging systems. Do not reroute engine compartment wiring.
- (6) Full copper circuitry and standardized polarity grounds are recommended.
- (7) Never increase the rating of a factory installed fuse or circuit breaker.
- (8) Disconnect the battery negative (ground) wire prior to any vehicle modification.

Following the above guidelines will provide you with years of trouble free service. Failing to incorporate the above guidelines may result in a voided warranty. Non-compliance with the guidelines above may result in a failure of electrical components, shutdown of engines, loss of backup brake systems, and the possibility of fire.