

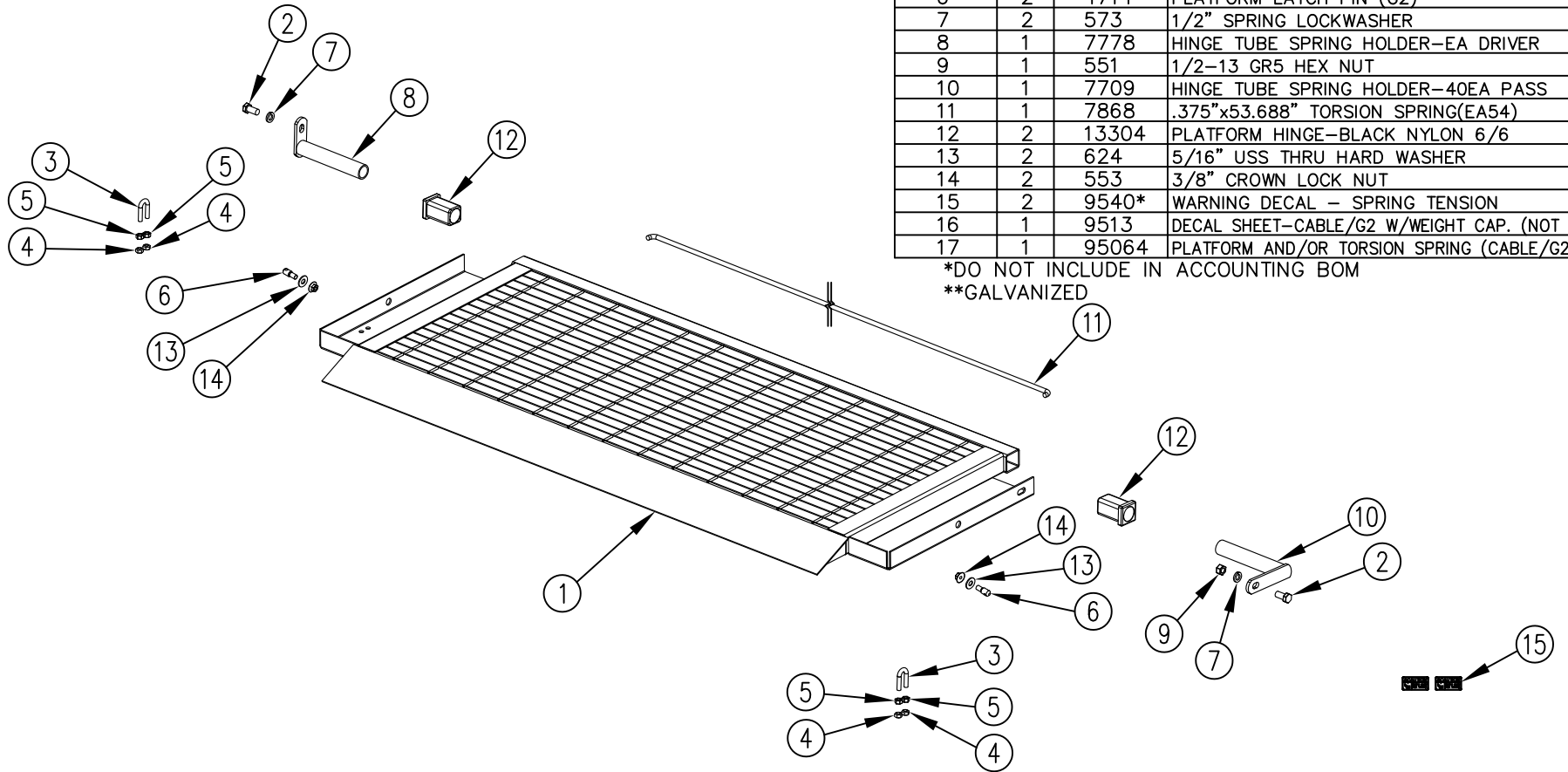

ITEM NO.	QTY.	PART NO.	DESCRIPTION
1	1	6198**	G2 54-42 22+4" BG PLATFORM COMPLETE
2	2	587	1/2-13x1" HHCS GR5
3	2	4727	3/8"U-BOLT(SHORT)x16x7/8x1-1/2
4	4	605	3/8-16 USS CROWN LOCK NUT
5	4	550	3/8-16 GR5 HEX NUT
6	2	4714	PLATFORM LATCH PIN (G2)
7	2	573	1/2" SPRING LOCKWASHER
8	1	7778	HINGE TUBE SPRING HOLDER-EA DRIVER
9	1	551	1/2-13 GR5 HEX NUT
10	1	7709	HINGE TUBE SPRING HOLDER-40EA PASS
11	1	7868	.375"x53.688" TORSION SPRING(EA54)
12	2	13304	PLATFORM HINGE-BLACK NYLON 6/6
13	2	624	5/16" USS THRU HARD WASHER
14	2	553	3/8" CROWN LOCK NUT
15	2	9540*	WARNING DECAL - SPRING TENSION
16	1	9513	DECAL SHEET-CABLE/G2 W/WEIGHT CAP. (NOT SHOWN)
17	1	95064	PLATFORM AND/OR TORSION SPRING (CABLE/G2) INSTR.



\*DO NOT INCLUDE IN ACCOUNTING BOM  
 \*\*GALVANIZED

NOTES: APPLY DECALS FROM 9513 SHEET SAME AS PRODUCTION  
 SEND (2) 9540 LOOSE

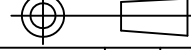
				THIRD ANGLE PROJECTION			FILENAME:		WOODBINE MFG. CO. BUS BROWN DRIVE WOODBINE, IOWA 51579 			
							SYMBOLY PER ANSI Y14.5				NOTES:	
				DECIMAL 2PLC 3PLC			DRAWN BY. AAS					
				MACHINE SAW, DRILL .030 .015			DRAWN/DATE 9/6/24					
				SHEAR, PUNCH FORM .060 .030					THE INFORMATION HERE IS CONFIDENTIAL AND MUST NOT BE USED IN ANYWAY DETRIMENTAL TO THE INTEREST OF WOODBINE MFG.			
				TORCH, WELDING ROUGH CAST .090 .060							TITLE G2 54 27+0+4 BG REPLACEMENT PLATFORM-GALVANIZED	
A	9/6/24	RELEASED TO PRODUCTION			AAS		3051			SCALE 1:14	FIN. WT.	PART NO. 18319
REV.	DATE	CHANGE RECORD			BY	APPVD	ECN					