

ITEM NO.	QTY.	PART NO.	DESCRIPTION
1	1	2060	(72) 36+6" TREADPLATE PLATFORM COMPLETE
2	1	7871	.38"x70" TORSION SPRING(72EA)
3	2	4727	3/8"U-BOLT(SHORT)x16x7/8x1-1/2
4	4	605	3/8-16 USS CROWN LOCK NUT
5	4	550	3/8-16 GR5 HEX NUT
6	2	587	1/2-13x1" HHCS GR5
7	1	588	1/2-13 GR5 HEX NUT (ZINC)
8	1	7431	PASS SIDE SPRING HOLDER(62 DEG)
9	1	7778	HINGE TUBE SPRING HOLDER-EA DRIVER
10	2	573	1/2" SPRING LOCKWASHER
11	1	9513	DECAL SHEET - CABLE/G2 W/WEIGHT CAP.
12	2	9540*	CAUTION DECAL - SPRING TENSION
13	1	95064	PLAT. AND/OR TORSION SPRING INSTRUCTIONS

*DO NOT INCLUDE IN ACCOUNTING BOM

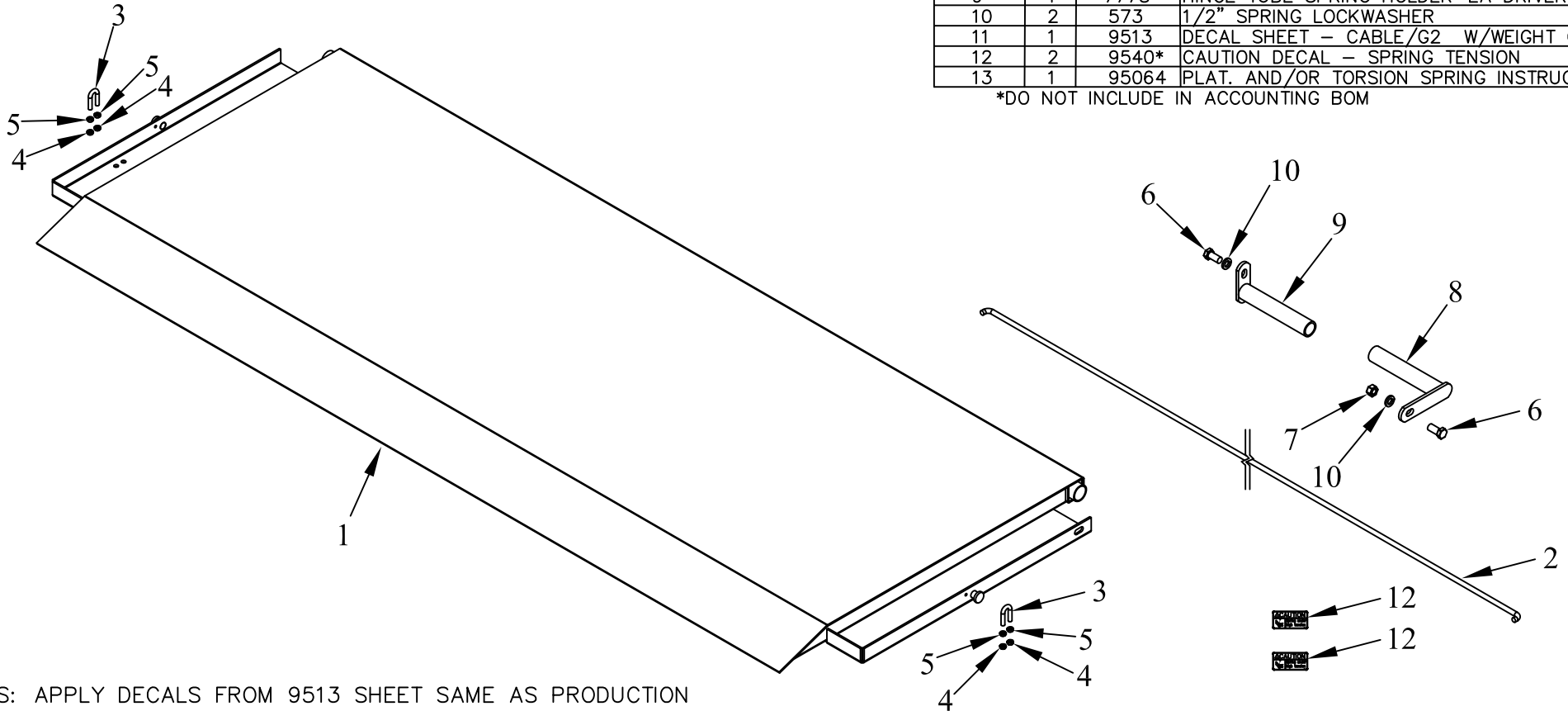

NOTES: APPLY DECALS FROM 9513 SHEET SAME AS PRODUCTION
SEND (2) 9540 LOOSE

REV.	DATE	CHANGE RECORD	BY	APPVD	ECN	DRAFT	ANGULAR	FILENAME:	TITLE	SCALE	FIN. WT.	PART NO.
D	1/24/17	ADDED 9513, 9540, 95064	AAS		1783	2'	±1°	THIRD ANGLE PROJECTION SYMBOLY PER ANSI Y14.5	(72) 36+6" TP REPLACEMENT PLATFORM	N	281	1784
C	1/14/15	REPLACED 7710 WITH 7431; ADDED 9513, 9540, AND 95064	JCB		1299			DECIMAL MACHINE SAW, DRILL	NOTES:			
B	3/12/10	REMOVED PN8028; ADDED PN7871, 587, 551, 7710, 7778, 573	MTC		274			2PLC SHEAR, PUNCH FORM	DRAWN BY: DJR			
A	5/22/06	UPDATED BOM	JCB	KGJ				3PLC TORCH, WELDING ROUGH CAST	DRAWN/DATE 3/15/05			
<p>WOODBINE MFG. CO. BUS BROWN DRIVE WOODBINE, IOWA 51579</p> <p>The original TOMMY GATE hydraulic lift</p> <p>THE INFORMATION HERE IS CONFIDENTIAL AND MUST NOT BE USED IN ANYWAY DETRIMENTAL TO THE INTEREST OF WOODBINE MFG.</p>												