

ITEM NO.	QTY.	PART NO.	DESCRIPTION
1	1	012818	25" EA MAIN PLATFORM(TUCKUNDER)
2	4	011644	.75"DIA.x17.75"SS EA HINGE PIN (TUCKUNDER)
3	6	011642	1.06"x1.25"x2.75" EA PLAFRM PIVOT HINGE (TKT)
4	8	011650	7/32"x1-1/4" SLOTTED SPRING PIN
5	12	000576	1/2" USS FLAT WASHER
6	12	000573	1/2" SPRING LOCK WASHER
7	12	000587	1/2-13x1" HHCS GR5
8	2	013060	PLATED EA OUTSIDE PLATFORM PIVOT HINGE
9	6	009023	2" LARGE BLACK PLUG
10	1	009506	DECAL SHEET-RAILGATE
11	1	095168	REPAIR TKT EA PLATFORM INSTRUCTIONS
12	1	095203	REPAIR TKT EA PLATFORM FLIPPER INSTRUCTIONS

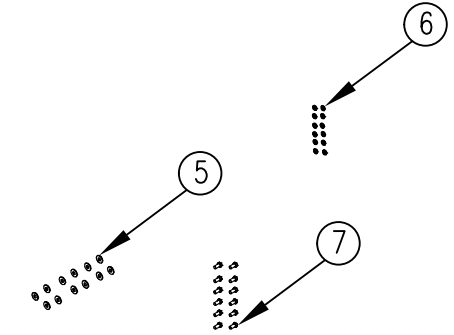
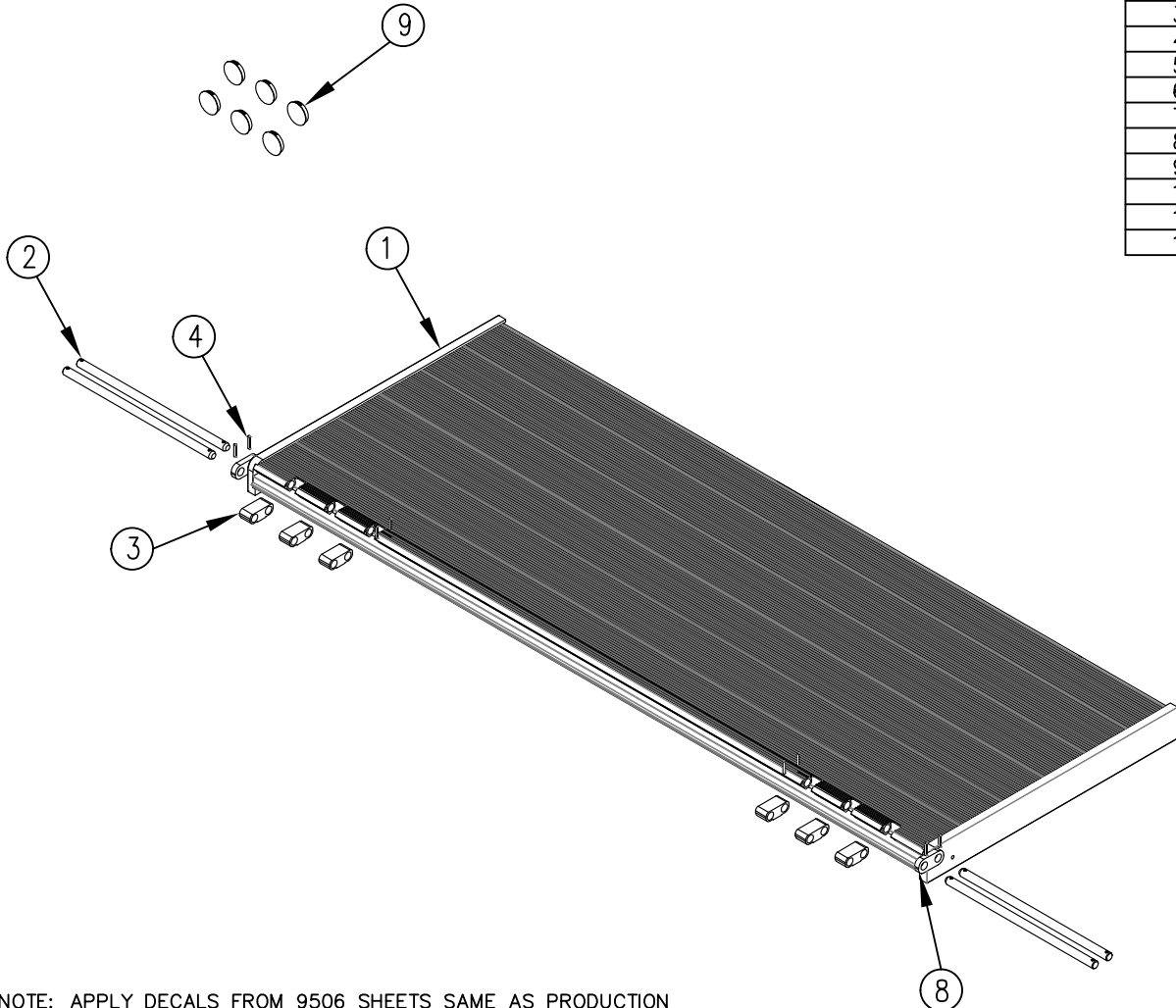

NOTE: APPLY DECALS FROM 9506 SHEETS SAME AS PRODUCTION

REV.	DATE	CHANGE RECORD	BY	APPVD	ECN	DRAFT	ANGULAR	SALES CATEGORY	PRODUCT LINE	SCALE	FIN. WT.	PART NO.	
B	4/6/16	UPDATED BOM TO MATCH PRODUCTION	GDB		1600	2'	±1°			1:8			
A.1	3/25/15	BILL CORRECTIONS TO MATCH PRODUCTION	GDB										
A	3/20/15	RELEASED TO PRODUCTION	GDB		1348								
						THIRD ANGLE PROJECTION	FILENAME:		WOODBINE MFG. CO. BUS BROWN DRIVE WOODBINE, IOWA 51579				
							SYMBOLY PER ANSI Y14.5		NOTES:				
						DECIMAL	2PLC	3PLC	DRAWN BY				
						MACHINE SAW, DRILL	.030	.015	GDB				
						SHEAR, PUNCH FORM	.060	.030	DRAWN/DATE				
						TORCH, WELDING ROUGH CAST	.090	.060	3/19/15				
									APPVD/DATE		TITLE		
											REPL. 25" EA MAIN PLATFORM (TUCKUNDER)		
									SALES CATEGORY	PRODUCT LINE	SCALE	FIN. WT.	PART NO.
											1:8		14336

The original
TOMMY GATE
hydraulic lift

THE INFORMATION HERE IS CONFIDENTIAL AND MUST NOT BE USED IN ANYWAY DETRIMENTAL TO THE INTEREST OF WOODBINE MFG.