

ITEM NO.	QTY.	PART NO.	DESCRIPTION
1	1	3541	48-1036-F11 STEEL TREADPL PLAT COMPL
2	1	3770	.38"x50.75" TORSION SPRING(MINI&48)
3	1	10329	1.25" PUNCHED INNER HINGE TUBE (48)
4	2	4728	3/8"U-BOLT(LONG)x16x7/8x2-1/16
5	4	605	3/8-16 USS CROWN LOCK NUT
6	4	550	3/8-16 GR5 HEX NUT
7	1	7491	SPRING HOLDER
8	1	4726	5/16" U-BOLT
9	1	508	3/8-16x3/4" HHCS GR5
10	1	510	3/8-16x1-1/4" HHCS
11	1	7304	10GA.x1"x2.75" SPRING CLIP
12	2	606	5/16-18 USS CROWN LOCK NUT
13	2	4720	1/4"x2" COTTER PIN
14	2	9540	WARNING DECAL - SPRING TENSION

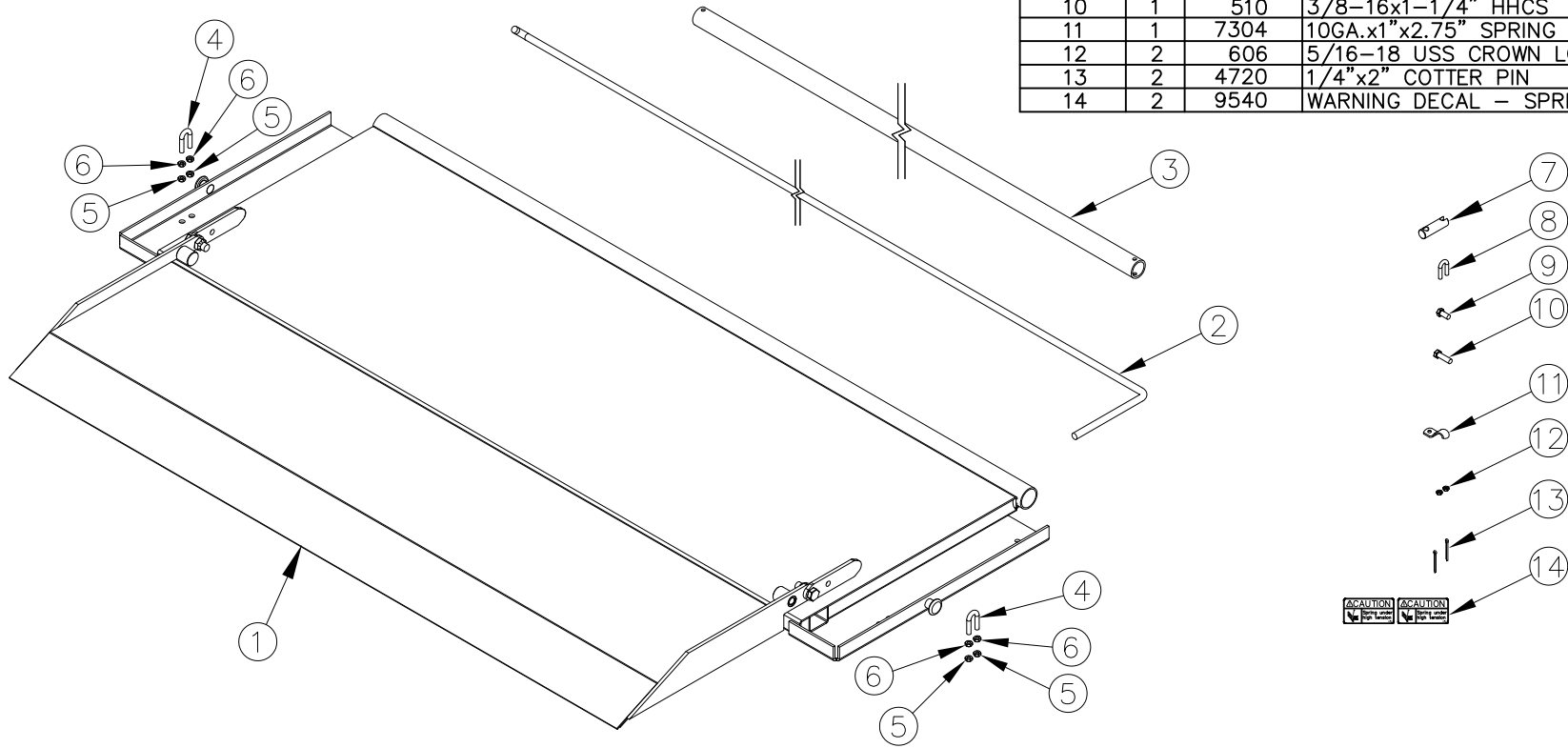

				THIRD ANGLE PROJECTION		FILENAME:		WOODBINE MFG. CO.															
						SYMBOLY PER ANSI Y14.5		BUS BROWN DRIVE															
				<table border="1"> <tr> <th>DECIMAL</th> <th>2PLC</th> <th>3PLC</th> </tr> <tr> <td>MACHINE SAW, DRILL</td> <td>.030</td> <td>.015</td> </tr> <tr> <td>SHEAR, PUNCH FORM</td> <td>.060</td> <td>.030</td> </tr> <tr> <td>TORCH, WELDING ROUGH CAST</td> <td>.090</td> <td>.060</td> </tr> </table>		DECIMAL	2PLC	3PLC	MACHINE SAW, DRILL	.030	.015	SHEAR, PUNCH FORM	.060	.030	TORCH, WELDING ROUGH CAST	.090	.060	DRAWN BY. DJR		NOTES:		WOODBINE, IOWA 51579	
DECIMAL	2PLC	3PLC																					
MACHINE SAW, DRILL	.030	.015																					
SHEAR, PUNCH FORM	.060	.030																					
TORCH, WELDING ROUGH CAST	.090	.060																					
				DRAWN/DATE 10/1/04		712-647-2050																	
				APPVD/DATE		TITLE		<small>THE INFORMATION HERE IS CONFIDENTIAL AND MUST NOT BE USED IN ANYWAY DETRIMENTAL TO THE INTEREST OF WOODBINE MFG.</small>															
B	10/12/10	REPLACED KITS WITH INDIVIDUAL PARTS; REPLACED 6400 WITH 10329; REPLACED 4727 WITH 4728		JCB		276	(48-1036-F11) TP REPLACMENT PLATFORM																
REV.	DATE	CHANGE RECORD		BY	APPVD	ECN	SALES CATEGORY	PRODUCT LINE	SCALE	FIN. WT.	PART NO.												
									N		1647												