

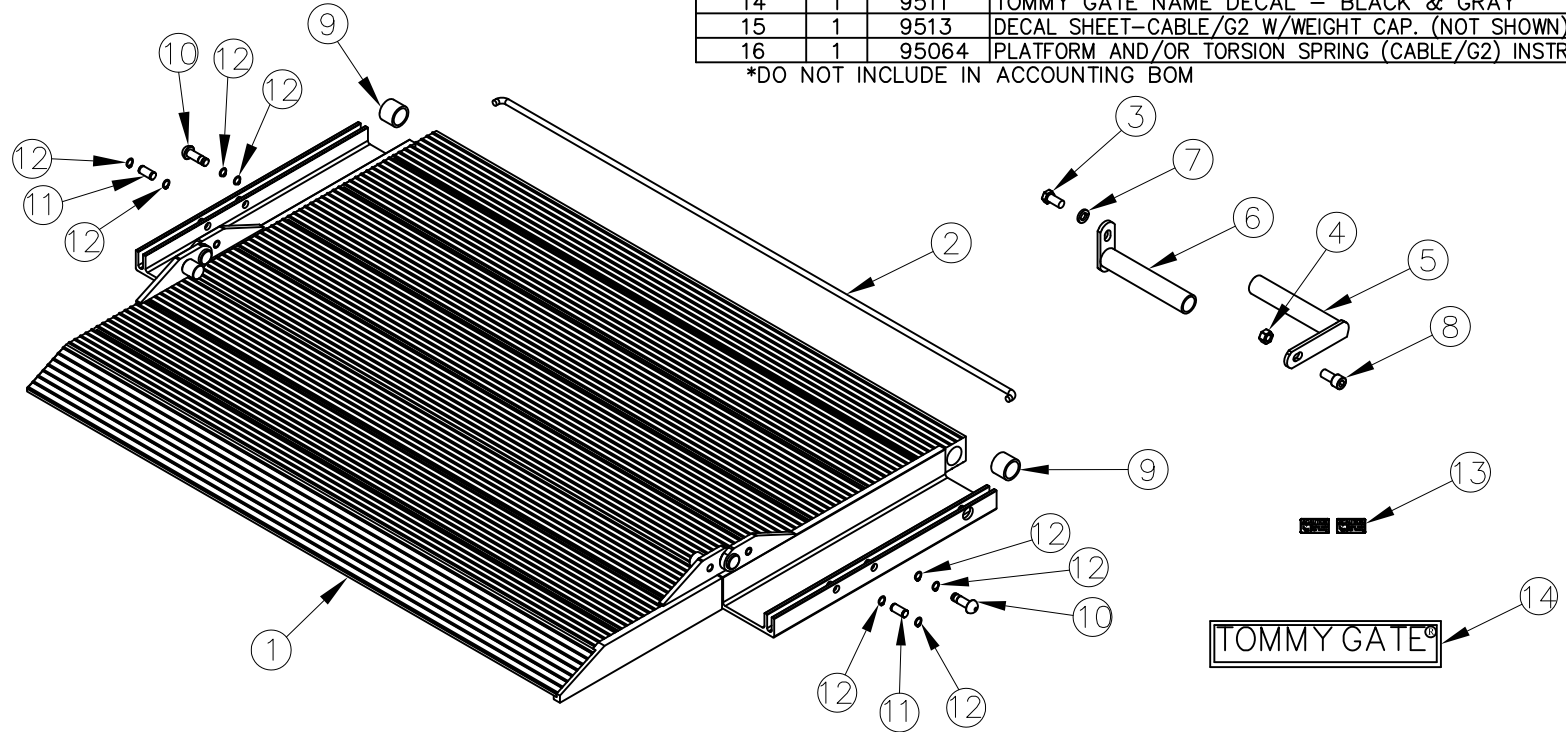

ITEM NO.	QTY.	PART NO.	DESCRIPTION
1	1	3405	48-F11 EA PLATFORM COMPLETE
2	1	7867	.38"x47.688" TORSION SPRING(48EA)
3	1	587	1/2-13x1" HHCS GR5
4	1	588	1/2-13 CROWN LOCK NUT
5	1	7709	HINGE TUBE SPRING HOLDER-40EA PASS
6	1	7778	HINGE TUBE SPRING HOLDER-EA DRIVER
7	1	573	1/2" SPRING LOCKWASHER
8	1	604	1/2-13x1"USS SOC HD CAP STAINLESS
9	2	8920	1.063"x1.38" I.D.x1.66" O.D.x.140" AL TUBING
10	2	7715	0.5"DIA X 1.5" SS EA PLAT LATCH PIN (34-40)
11	2	7637	0.5"DIA X 1.079" EA PLAT CHAIN PIN (34-40)
12	8	614	1/2"EXTERNAL SNAP RING
13	2	9540*	WARNING DECAL - SPRING TENSION
14	1	9511	TOMMY GATE NAME DECAL - BLACK & GRAY
15	1	9513	DECAL SHEET-CABLE/G2 W/WEIGHT CAP. (NOT SHOWN)
16	1	95064	PLATFORM AND/OR TORSION SPRING (CABLE/G2) INSTR.

*DO NOT INCLUDE IN ACCOUNTING BOM



NOTES: APPLY DECALS FROM 9513 SHEET SAME AS PRODUCTION
SEND (2) 9540 LOOSE

REV.	DATE	CHANGE RECORD	BY	APPVD	ECN	DRAFT 2"	ANGULAR ±1°	SALES CATEGORY	PRODUCT LINE	SCALE N	FIN. WT.	PART NO. 1630
								FILENAME:	WOODBINE MFG. CO. BUS BROWN DRIVE WOODBINE, IOWA 51579  <small>THE INFORMATION HERE IS CONFIDENTIAL AND MUST NOT BE USED IN ANYWAY DETRIMENTAL TO THE INTEREST OF WOODBINE MFG.</small>			
								SYMBOLY PER ANSI Y14.5				
								NOTES:				
								DRAWN BY. DJR				
D	9/30/16	ADDED (1) 9511 (1) 9513, (1) 95064	AAS		1709			DRAWN/DATE 8/24/04				
C	11/15/10	ADDED (2) 9540	JCB		367			APPVD/DATE	TITLE 48 w/F11 EA REPLACMENT PLATFORM			
B	5/20/10	REPLACED KITS WITH INDIVIDUAL PARTS; REMOVED (2) 2020, (2) 8919; ADDED (1) 8920	JCB		276							