

ITEM NO.	QTY.	PART NO.	DESCRIPTION
1	1	013123	G2 SUB ASSEMBLY(73-42)
2	1	000587	1/2-13x1" HHCS GR5
3	1	000573	1/2" SPRING LOCK WASHER
4	1	000588	1/2-13 CROWN LOCK NUT
5	1	000604	1/2-13x1" USS SOC HD CAP S.S.
6	2	002940	G2 RUBBER BUMPER
7	2	009042	G2 SUB ASSEMBLY BELTING 21-3/8"
8	8	000620	1/4-20X1/2" PN HD TY FS(G2)
9	4	002879	.75"DIA.x2.109"PIN w/FLAT HEAD KEEPER(G2)
10	4	002025	3/4"EXTERNAL SNAP RING (G2) PLATED
11	4	002109	.75"IDx1"ODx1.5"BEARING (G2)
12	4	000756	1/4-20x3/4" PHI FH TYPE F SS

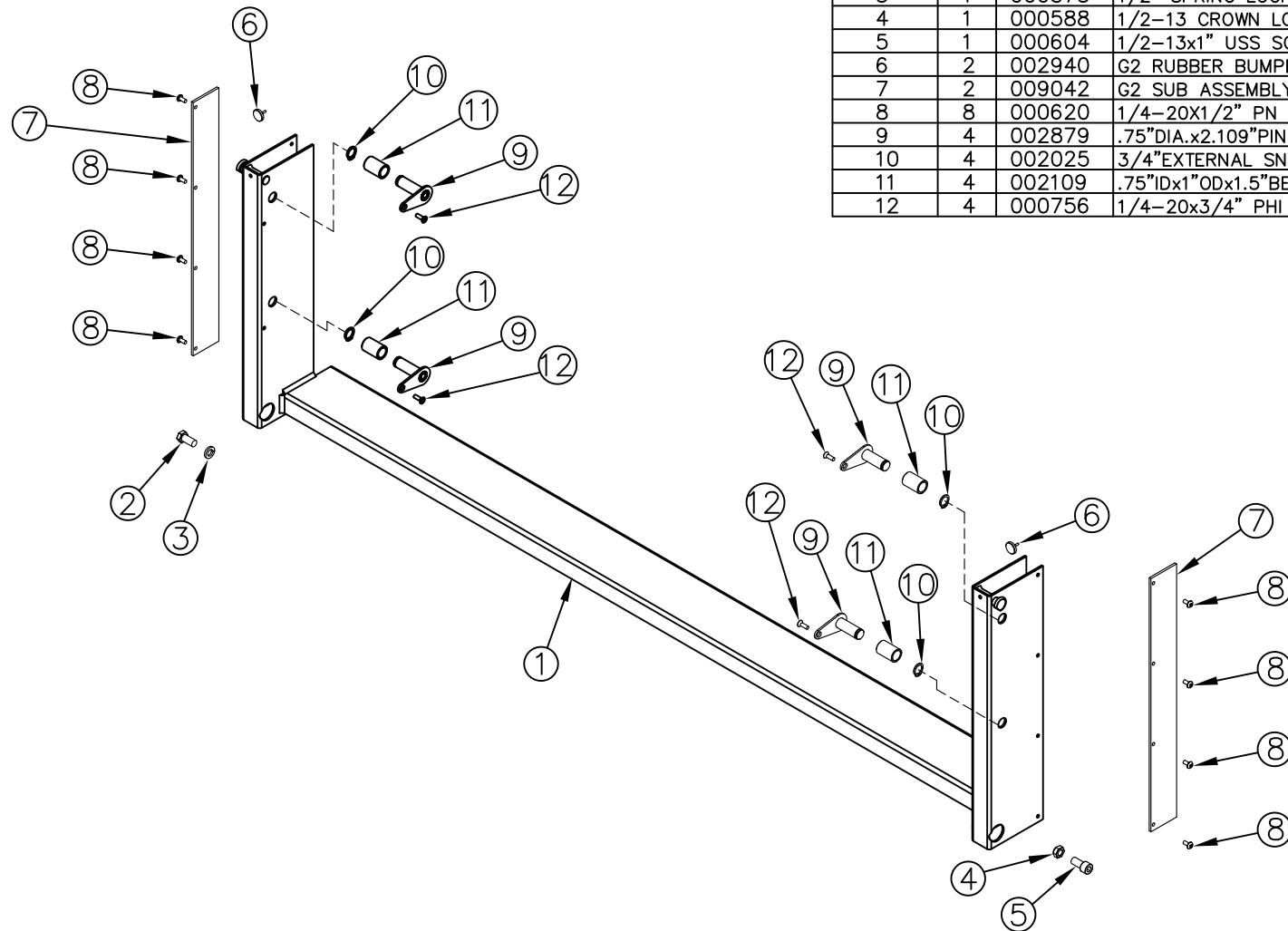

				THIRD ANGLE PROJECTION			FILENAME:				WOODBINE MFG. CO. BUS BROWN DRIVE WOODBINE, IOWA 51579																															
							SYMBOLY PER ANSI Y14.5								NOTES:																											
				<table border="1"> <tr> <th>DECIMAL</th> <th>2PLC</th> <th>3PLC</th> </tr> <tr> <td>MACHINE SAW, DRILL</td> <td>.030</td> <td>.015</td> </tr> <tr> <td>SHEAR, PUNCH FORM</td> <td>.060</td> <td>.030</td> </tr> <tr> <td>TORCH, WELDING ROUGH CAST</td> <td>.090</td> <td>.060</td> </tr> </table>			DECIMAL	2PLC	3PLC	MACHINE SAW, DRILL	.030	.015	SHEAR, PUNCH FORM	.060					.030	TORCH, WELDING ROUGH CAST	.090	.060	DRAWN BY: AAS				<table border="1"> <tr> <td colspan="2">DRAWN/DATE</td> <td colspan="2">9/6/24</td> </tr> <tr> <td colspan="2">APPVD/DATE</td> <td colspan="2">TITLE</td> </tr> <tr> <td colspan="2"></td> <td colspan="2">G2 73-42 LOW PROFILE REPAIR SUB ASSEMBLY</td> </tr> </table>				DRAWN/DATE		9/6/24		APPVD/DATE		TITLE				G2 73-42 LOW PROFILE REPAIR SUB ASSEMBLY	
DECIMAL	2PLC	3PLC																																								
MACHINE SAW, DRILL	.030	.015																																								
SHEAR, PUNCH FORM	.060	.030																																								
TORCH, WELDING ROUGH CAST	.090	.060																																								
DRAWN/DATE		9/6/24																																								
APPVD/DATE		TITLE																																								
		G2 73-42 LOW PROFILE REPAIR SUB ASSEMBLY																																								
A	9/6/24	RELEASED TO PRODUCTION				AAS	3051																																			
REV.	DATE	CHANGE RECORD				BY	APPVD	ECN	DRAFT 2"	ANGULAR ±1"	SALES CATEGORY	PRODUCT LINE	SCALE 1:12	FIN. WT.	PART NO. 18311																											