

ITEM NO.	QTY.	PART NO.	DESCRIPTION
1	1	4839	G2 54-42 22+4" TP PLATFORM
2	2	587	1/2-13x1" HHCS GR5
3	2	4727	3/8"U-BOLT(SHORT)x16x7/8x1-1/2
4	4	605	3/8-16 USS CROWN LOCK NUT
5	4	550	3/8-16 GR5 HEX NUT
6	2	4714	PLATFORM LATCH PIN (G2)
7	2	573	1/2" SPRING LOCKWASHER
8	1	7778	HINGE TUBE SPRING HOLDER-EA DRIVER
9	1	551	1/2-13 GR5 HEX NUT
10	1	7709	HINGE TUBE SPRING HOLDER-40EA PASS
11	1	7868	.375"x53.688" TORSION SPRING(EA54)
12	2	13304	PLATFORM HINGE-BLACK NYLON 6/6
13	2	624	5/16" USS THRU HARD WASHER
14	2	553	3/8" CROWN LOCK NUT
15	2	9540*	WARNING DECAL - SPRING TENSION
16	1	9513	DECAL SHEET-CABLE/G2 W/WEIGHT CAP. (NOT SHOWN)
17	1	95064	PLATFORM AND/OR TORSION SPRING (CABLE/G2) INSTR.

*DO NOT INCLUDE IN ACCOUNTING BOM

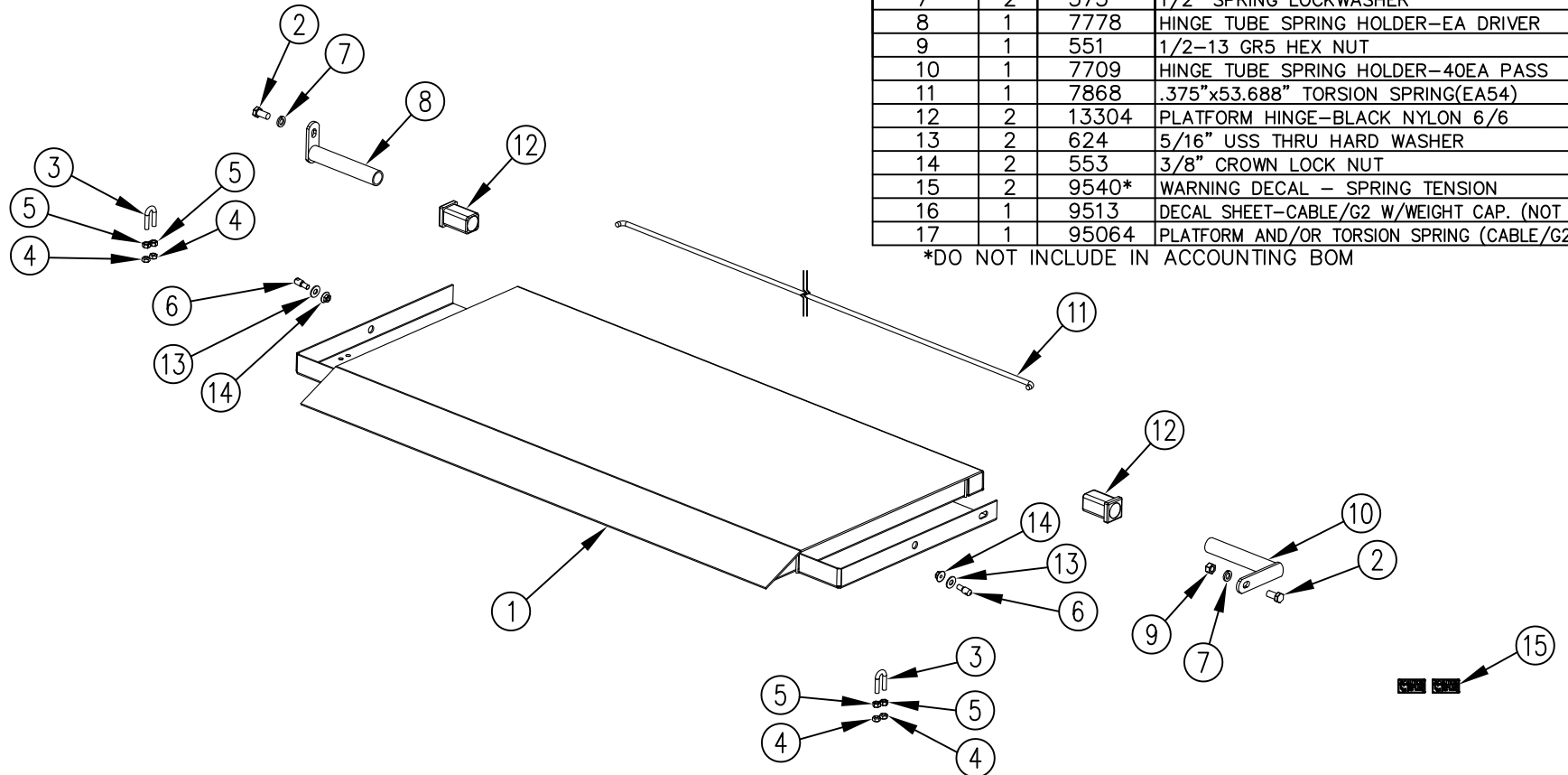

NOTES: APPLY DECALS FROM 9513 SHEET SAME AS PRODUCTION
SEND (2) 9540 LOOSE

D.1	8/17/16	UPDATED TITLE BLOCK	AAS			THIRD ANGLE PROJECTION	FILENAME:	WOODBINE MFG. CO. BUS BROWN DRIVE WOODBINE, IOWA 51579					
D	3/20/14	REPLACED 2020 W/ INDIVIDUAL PARTS; ADDED (2) 9540, (1) 9513, (1) 95064, & NOTES	JCB		1063		SYMBOLY PER ANSI Y14.5	NOTES:					
C	10/10/13	ADDED (1) 7868, AND (2) 13304, REMOVED ACCOUNTING NOTE	GDB		979	DECIMAL	2PLC					3PLC	DRAWN BY. JCB
B	3/15/10	REMOVED PN604, 588; ADDED PN551; ADDED ONE MORE PN573, 587	MTC		274	MACHINE SAW,DRILL	.030	.015	DRAWN/DATE 7/25/06	THE INFORMATION HERE IS CONFIDENTIAL AND MUST NOT BE USED IN ANYWAY DETRIMENTAL TO THE INTEREST OF WOODBINE MFG.			
A	7/25/06	DRAWN IN AUTOCAD	JCB	KGJ		SHEAR, PUNCH FORM	.060	.030	APPVD/DATE	TITLE G2 54 27+0+4 TP REPLACEMENT PLATFORM			
REV.	DATE	CHANGE RECORD	BY	APPVD	ECN	TORCH, WELDING ROUGH CAST	.090	.060	SALES CATEGORY	PRODUCT LINE	SCALE 1:14	FIN. WT.	PART NO. 4833
						DRAFT 2"							
						ANGULAR ±1"							