

INSTALLATION INSTRUCTIONS

Tuckunder Series 2500/3000 lb Capacity

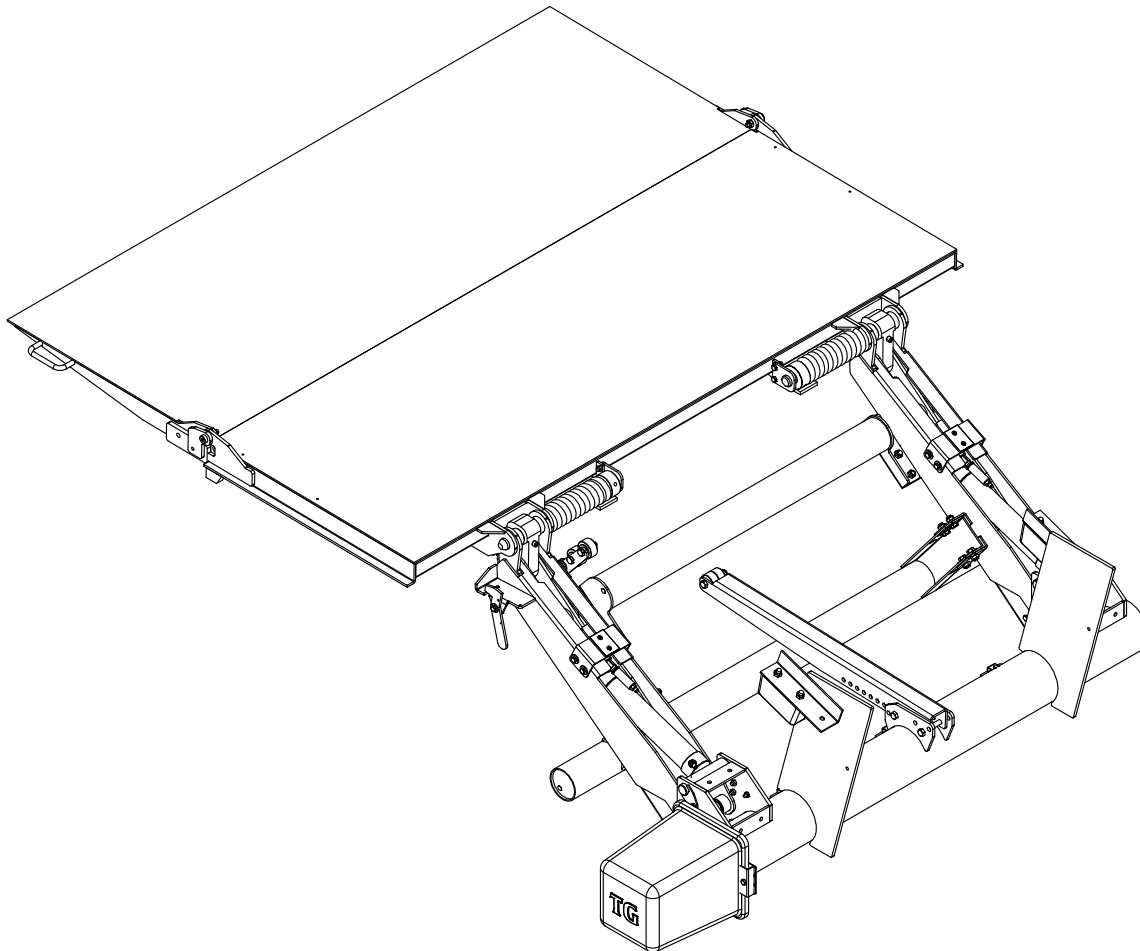

Woodbine, Iowa



Before installing this liftgate, please observe the Vehicle Loading Limitations. These loading limitations are outlined in the Vehicle Owner's Manual and the Safety Compliance Certification Label located on the drivers door pillar.



TABLE OF CONTENTS

| <u>Introduction</u> | Page # |
|---|---------------|
| To the Installer\Operator _____ | 3 |
| | |
| <u>Safety Decals and Tuckunder Description</u> | |
| Safety Decal Location and Descriptions _____ | 4-5 |
| Decal Replacement _____ | 5 |
| Tuckunder Terms and Method of Operation _____ | 6 |
| | |
| <u>Gate Installation Process</u> | |
| Mounting Location Guide _____ | 7 |
| Preparing the Gate _____ | 8 |
| General Installation Notes _____ | 9 |
| Preparing the Truck _____ | 9 |
| Positioning the Bed Extension on the Truck _____ | 10 |
| Positioning the Liftgate on the Truck _____ | 11-13 |
| Finish Welding and Snubber Kit _____ | 14-15 |
| Finishing Gate Installation _____ | 16 |
| | |
| <u>Electrical Wiring</u> | |
| Routing the Power Cables _____ | 17 |
| Standard Fixed Control _____ | 18 |
| Optional Pendant Control _____ | 19 |
| Power Unit Control Circuit _____ | 20 |
| Tommy Gate Electrical Wiring Guidelines _____ | 21 |
| | |
| <u>Testing and Operation</u> | |
| Testing the Liftgate _____ | 22 |
| Painting the Liftgate _____ | 22 |
| Platform Adjustment Instructions _____ | 23 |
| Operator's Instructions _____ | 24-25 |
| Reflective Flag Install _____ | 26 |

TO THE INSTALLER\OPERATOR:

Read this manual completely before using your gate. Operate and maintain your gate safely as outlined in this manual. Be sure you read and understand all operating, safety, maintenance and service information. Should you need repair or service information, contact Tommy Gate or an authorized distributor for assistance.



This is the safety alert symbol. It is used to alert you to potential personal injury hazards. Obey all safety messages that follow this symbol to avoid possible injury or death.



DANGER indicates an imminently hazardous situation which, if not avoided, will result in death or serious injury.



WARNING indicates a potentially hazardous situation which, if not avoided, could result in death or serious injury.



CAUTION indicates a potentially hazardous situation which, if not avoided, may result in minor or moderate injury.



CAUTION indicates a potentially hazardous situation which, if not avoided, may result in property damage.

Safety is a primary concern in the design and manufacture of our products. Unfortunately, our efforts to provide safe equipment can be wiped out by a single careless act of an operator.

Accident prevention and safety are dependent upon the awareness, concern, prudence, and proper training of the personnel who operate, transport, maintain and store this equipment. It is your responsibility to use good judgment in the operation of this equipment.

It has been said that "**the best safety device is an informed, careful operator.**" We ask you to be that kind of operator.

DECAL LOCATIONS AND DESCRIPTIONS

Locate and read all decals prior to operating gate
REPLACE IF MISSING OR NOT READABLE

TOMMY GATE®

| | |
|---|---|
| <p>DO'S</p> <ul style="list-style-type: none"> * DO CENTER YOUR LOAD ON PLATFORM. * DO CLOSE AND LOCK LIFT IN CLOSED POSITION WHEN NOT IN USE OR UNATTENDED. * DO STAND TO THE SIDE OF LIFTGATE WHILE IT IS IN OPERATION. * DO READ MAINTENANCE AND SERVICE INFORMATION. * DO READ OPERATOR'S INSTRUCTIONS. * DO FREQUENTLY CHECK CABLES, CHAINS, AND OTHER COMPONENTS FOR WEAR OR DAMAGE AND REPAIR AS NECESSARY WITH PARTS PROVIDED BY THE ORIGINAL EQUIPMENT MANUFACTURER. * DO CHECK ALL SAFETY DEVICES FOR PROPER OPERATION. | <p>DO NOT'S</p> <ul style="list-style-type: none"> * DO NOT RIDE OR PERMIT ANYONE TO RIDE ON LIFT. THE LIFT IS NOT A PERSONNEL OR WHEELCHAIR LIFT. * DO NOT MAKE ANY MODIFICATIONS TO THE LIFT OR ITS SAFETY FEATURES. * DO NOT ALLOW USE OF LIFT BY A PERSON WHO HAS NOT HAD PROPER TRAINING IN ITS OPERATION. * DO NOT TRY TO LIFT OR LOWER MORE THAN THE RATED CAPACITY OF THE LIFT. * DO NOT ADD TO OR REMOVE PARTS OF LIFT AS IT WILL VOID YOUR WARRANTY. * DO NOT MOVE VEHICLE UNLESS GATE IS IN LATCHED POSITION. * DO NOT SHOW CHILDREN OR UNAUTHORIZED PERSONNEL HOW TO OPERATE LIFT. * DO NOT LEAVE PLATFORM OPEN, OR UNLATCHED WHEN LIFT IS NOT IN USE OR UNATTENDED. NEVER LEAVE PLATFORM DOWN TO BE USED AS A STEP. |
|---|---|

ALL REPAIRS OR REINSTALLATIONS OF TOMMY GATE LIFTS SHOULD BE PERFORMED BY AN AUTHORIZED DISTRIBUTOR THAT IS FAMILIAR WITH ITS OPERATION AND SAFETY FEATURES. ALL REPLACEMENT PARTS MUST BE OF ORIGINAL QUALITY, AND ALL SAFETY AND OPERATIONAL DECALS MUST BE ATTACHED AND LEGIBLE

9561

Decal No. 1
Place in cab in a highly visible area.

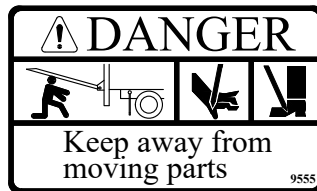

Decal No. 2
Located on each main platform lid end, near the hinge.

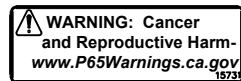

Decal No. 3
Located on the passenger side main platform lid end, near the hinge.

WARNING

Do not ride the platform.
This lift is not designed as a wheelchair or personnel lift.

Center Load

Center load on platform side to side and front to back.

Never allow children or any untrained person to operate the lift.
Do not show children or others how to operate the lift.
When the lift is not in use or unattended, the platform should be closed and latched with control secured.

9522

Decal No. 3
Located on the bottom side of the platform on the right-hand side.

The original

TOMMY GATE

hydraulic lift

Part Number:

Serial Number:

Woodbine Mfg Co
WOODBINE, IOWA (USA)
1-800-LIFTGATE

Decal No. 4
Located inside the pump cover.
Located on the lift arm below the gate latch.

DECAL LOCATIONS AND DESCRIPTIONS

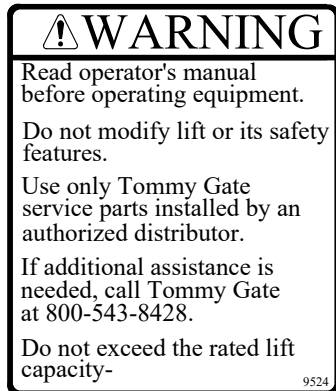

Decal No. 5
Located on outward facing side of the pump cover.

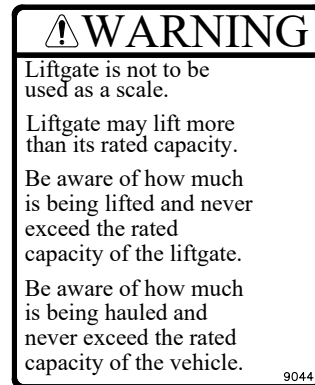

Decal No. 9
Located on the outward facing side of the pump cover.

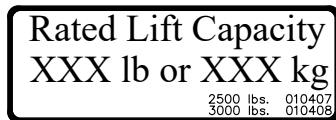

Decal No. 6
Located on the passenger side main platform lid end, near the hinge.



Decal No. 10
Located at each end of the rear facing side of the upper arm tube.

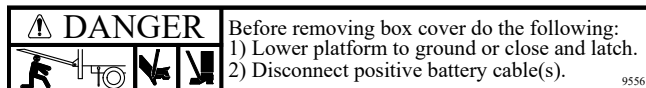

Decal No. 7
Located on outward facing side of the pump cover.



Decal No. 11
Located on the bottom side of the platform, on the right-hand side.



Decal No. 8
Located on the collar next to each coil spring.

DECAL REPLACEMENT

NOTE: When ordering Decals, please have Decal Numbers available.

To replace decal, clear area of grease and dirt with non-flammable solvent and soap and water. Allow to dry. To apply decal, peel off 1/2 of back. Hold decal squarely and apply to cleaned surface. Peel off remaining back and smooth in place. Gently rub decal with a damp rag or sponge to smooth out bubbles. (The decal has a pressure-sensitive adhesive on the back.)

If the liftgate **is** going to be painted, you need to mask the decals before painting. Remove the mask **after** painting so the decals can be read clearly.

Tuckunder Series Mounting Instructions

Tuckunder Terms and Method of Operation

Your Tommy Gate is connected to your vehicle battery. The vehicle battery powers a motor, coupled to a hydraulic pump. This motor and pump combination is called a power unit. Flow from the pump retracts two cylinders attached to the upper arm assembly that lift the gate platform. A check valve blocks return flow from the cylinder to the pump and a pressure relief valve prevents the gate from being overloaded.

!WARNING: Liftgate is not to be used as a scale. Liftgate may lift more than its rated capacity. Be aware of how much is being lifted and never exceed the rated capacity of the liftgate. Be aware of how much is being hauled and never exceed the rated capacity of the vehicle.

Placing the toggle switch into the lower position will direct the pump flow to extend the cylinder attached to the lift arm and the platform will lower. Once the lower arm contacts the ground the cylinder will continue to extend and will tilt the platform's taper end down.

The terms used to describe parts of the tuckunder in this manual can be found in (Figure 1).

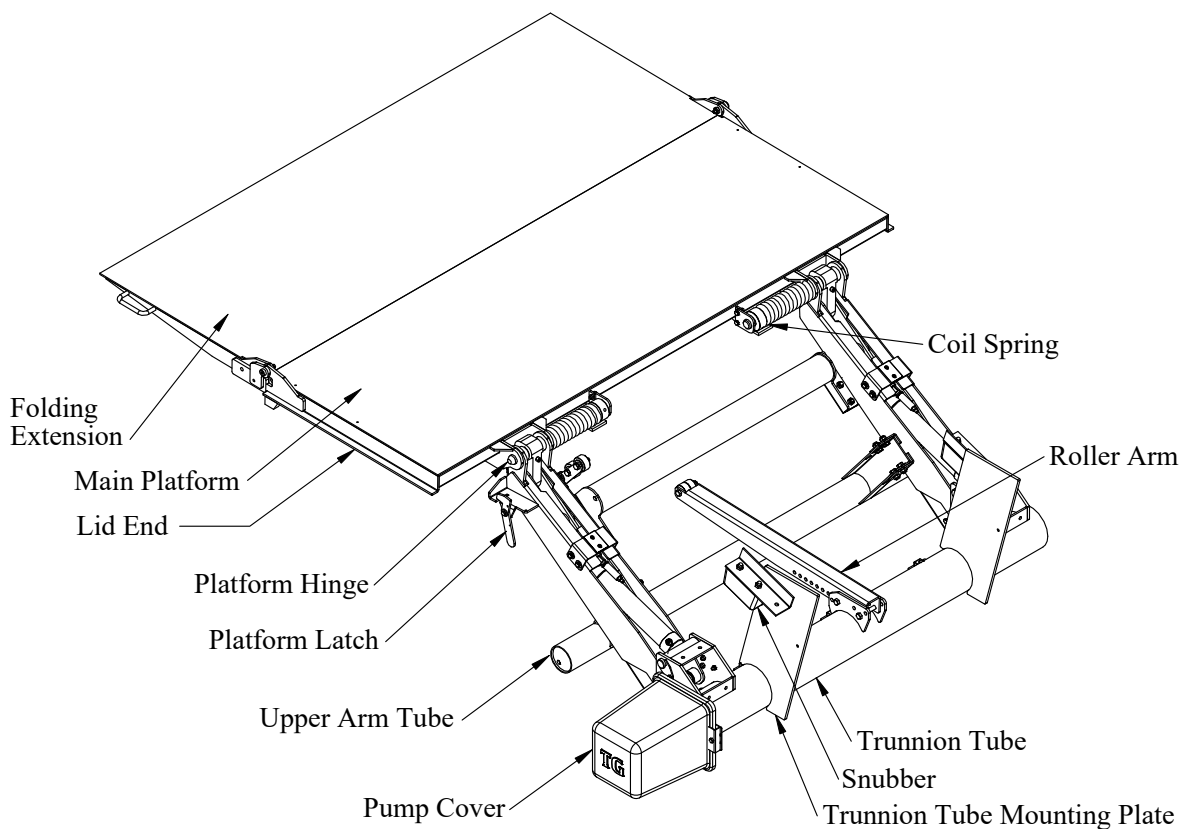

Figure 1: Tuckunder terms.

!Caution:

Never leave the truck with the platform on the ground, partially raised, or open.

Never show children or unauthorized personnel how to operate the gate.

To prevent children or unauthorized personnel from operating the lift, be sure the gate is in the stored position and the platform latch is secured. Make sure the platform latch padlock is installed and the control is deactivated before leaving the truck unattended.

!Warning: The Tommy Gate is an industrial product for material handling only and is not to be used as a personnel or wheelchair lift. Do not ride on the platform and always stand clear of the platform when opening, raising or lowering.

TKT MOUNTING LOCATION GUIDE 2500-3000 Lbs

| D- BED HEIGHT | E | E' | F | G | G' | H | Le | | Q | M | N | T | P | W |
|---------------|----|----|----|-------|-------|-------|------|-------|-------|-------|------|-----|-----|-----|
| | | | | | | | max | min | max | | min | | | |
| 40 | 22 | 16 | 18 | 49.00 | 44.25 | 41.00 | 32.0 | 43.0 | 7.6 | 46.0 | 43.5 | 6.0 | 6.0 | 2.7 |
| 41 | | | 19 | 48.50 | 43.75 | 40.50 | | | | | | | | |
| 42 | | | 20 | 48.00 | 43.25 | 40.00 | | | | | | | | |
| 43 | | | 21 | 47.25 | 42.50 | 39.25 | | | | | | | | |
| 44 | | | 22 | 46.50 | 41.75 | 38.50 | | | | | | | | |
| 45 | 23 | 17 | 23 | 45.75 | 41.00 | 37.75 | | | | | | | | |
| 46 | | | | | | | 24 | 46.50 | 41.75 | 38.50 | | | | |
| 47 | | | | | | | 25 | 47.25 | 42.50 | 39.25 | | | | |
| 48 | | | | | | | 26 | 48.00 | 43.25 | 40.00 | | | | |
| 49 | | | | | | | 27 | 48.50 | 43.75 | 40.50 | | | | |
| 50 | | | | | | | 28 | 49.00 | 44.25 | 41.00 | | | | |
| 51 | | | | | | | 29 | 49.50 | 44.75 | 41.50 | | | | |
| 52 | | | | | | | 30 | 50.00 | 45.25 | 42.00 | | | | |
| 53 | | | | | | | 31 | 50.50 | 45.75 | 42.50 | | | | |
| 54 | | | | | | | 32 | 51.00 | 46.25 | 43.00 | | | | |

All dimensions in inches.

Dimensions may vary depending on mounting requirements.

G: distance between the platform and the end of the bracket

G': distance between the platform and the end of the power unit

H : distance between the platform and the back of the trunnion

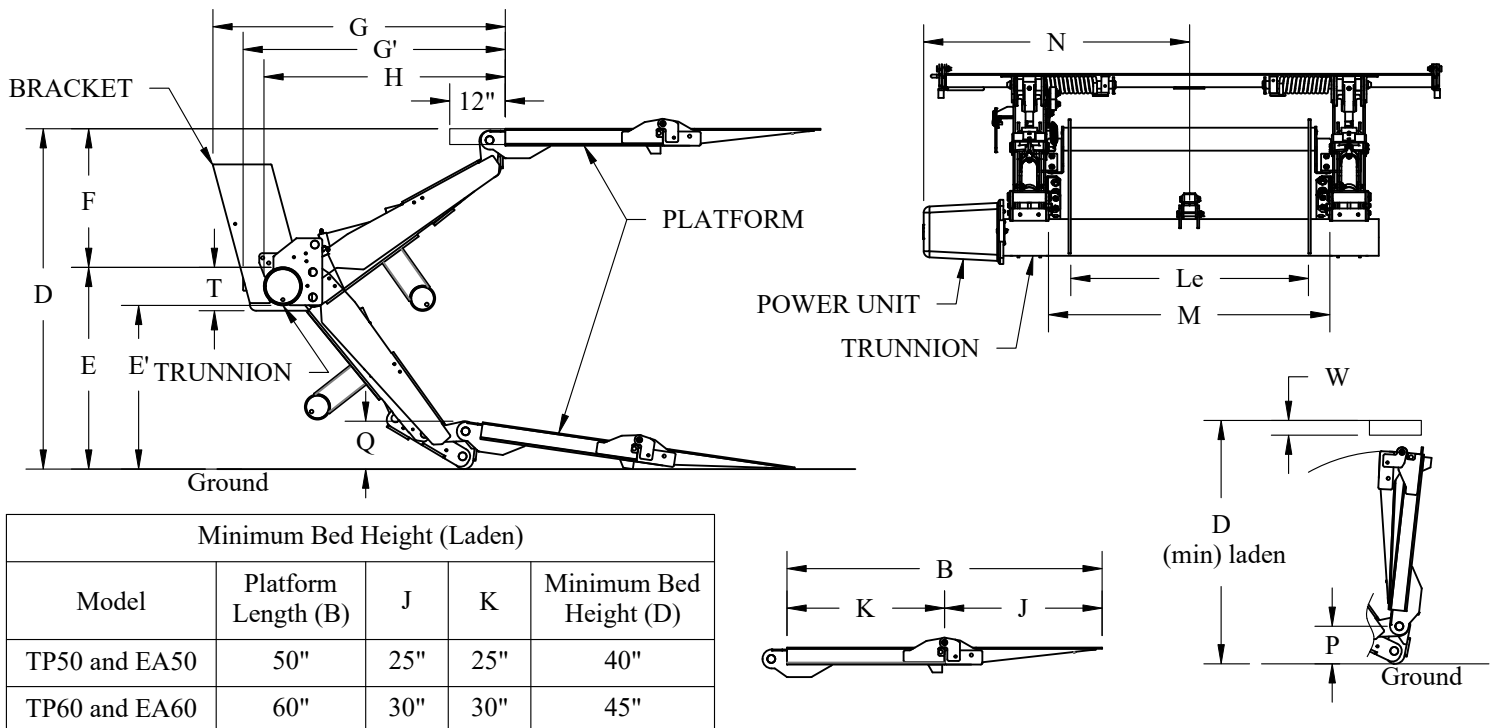

Figure 2: Liftgate General Dimensions

Tuckunder Series Mounting Instructions

Preparing the Gate

- 1. Measure** the body opening, the overall width, and the bed height of the truck.
Measure the distance from the rear of the body to rear tire or rear fuel tank.
Make sure you have the correct model of liftgate for your application.
- 2. Remove** banding from the palletized gate. Watch for loose or shifting parts.
Leave liftgate in folded position and attached to the shipping pallet.
- 3. Verify** parts list (Table 1) and inspect for missing or damaged parts (Figure 4).

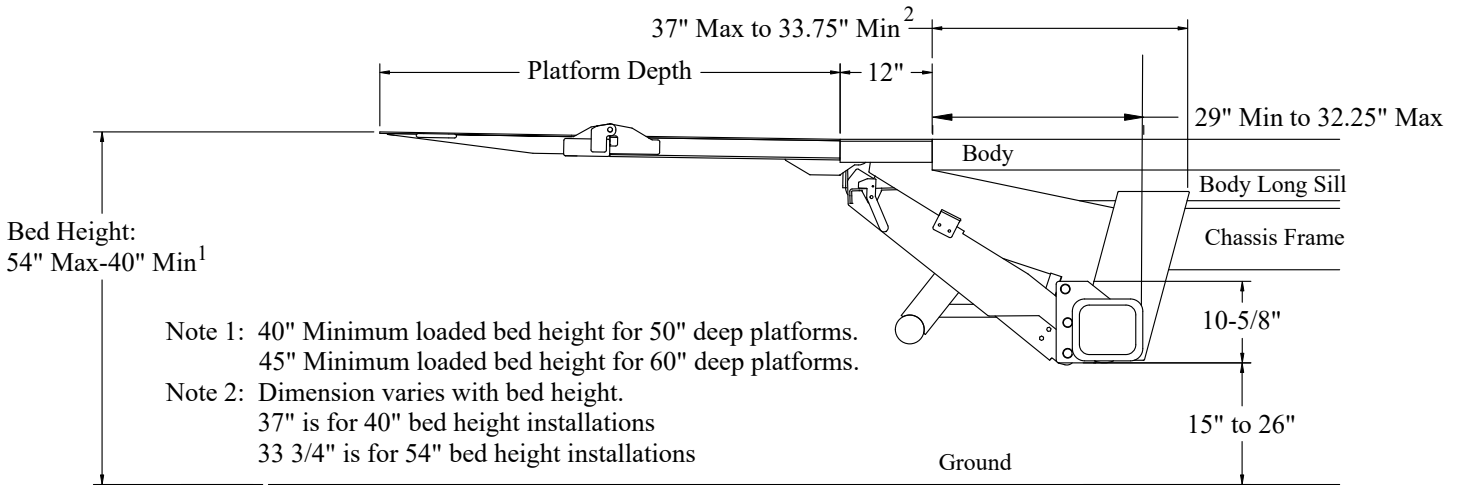
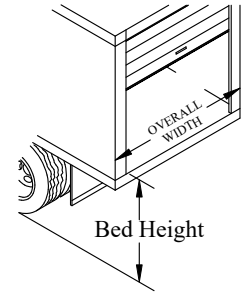

Figure 3: Body measurements.

Table 1: Parts List

| QTY. | DESCRIPTION |
|------|-------------------------------|
| 1 | Liftgate |
| 2 | Trunnion Tube Mounting Plates |
| 1 | Mounting Kit |
| 1 | Bed Extension |
| 2 | Bed Extension Braces |
| 4 | Brace Mounts w/ 1/2" Hardware |
| 2 | Brace Support Mounting Plates |
| 2 | Snubbers |

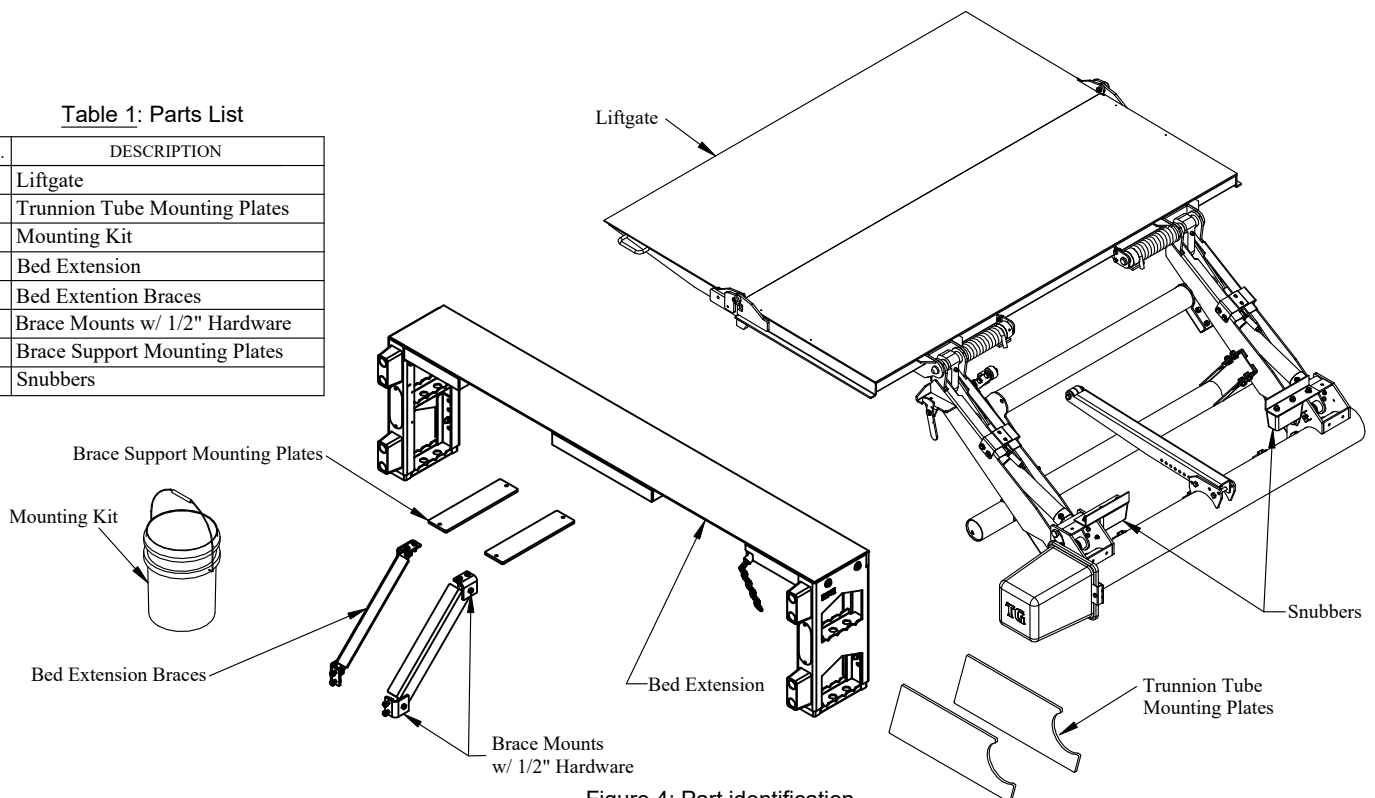

Figure 4: Part identification.

Tuckunder Series Mounting Instructions

General Installation Notes

1. Do not work under liftgate without platform being supported.

Do not remove fork lift or overhead crane without verifying the hydraulic system has been fully pressurized.

2. Use standard AWS (American Welding Society) D1.1 welding practices for specified welding details.

For galvanized units remove galvanizing from weld locations with a grinder before welding.
Be sure to provide adequate ventilation for welding.

!WARNING: Remove galvanizing from areas to be welded and avoid breathing fumes.

3. See recommended torque values for fasteners (Table 2).

Table 2: Fastener Torque Values

| Thread Size | Torque, ft-lb |
|-------------|---------------|
| 3/8-16 | 37 |
| 1/2-13 | 90 |
| 5/8-11 | 179 |

Preparing the Truck

1. Park truck on flat and level work surface for liftgate installation.

2. Disconnect the truck battery.

3. Measure the truck frame for platform folding clearance using the layout chart (Figure 5).

4. Trim the truck frame to provide platform folding clearance.

5. Prepare the mounting surfaces of the truck frame. The surfaces should be free of paint and rust.

Note: On installations such as a lengthened van body or rebuilt trailer, where the frame stops short of the end of the body, extra support may need to be added to minimize undesirable deflection under heavy load.

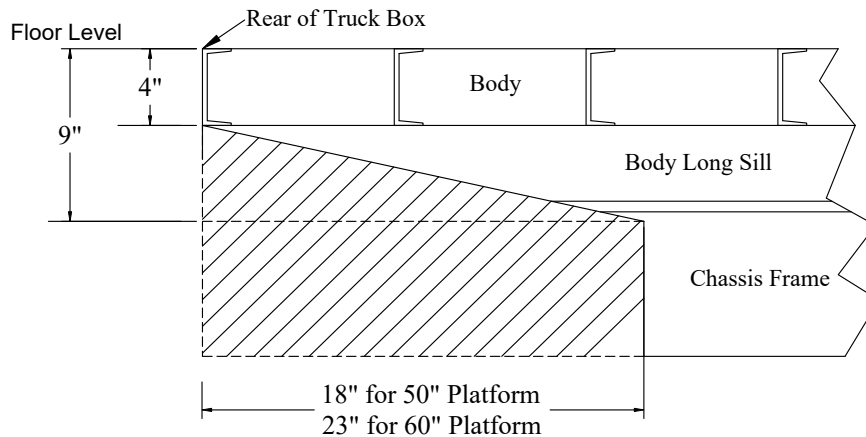
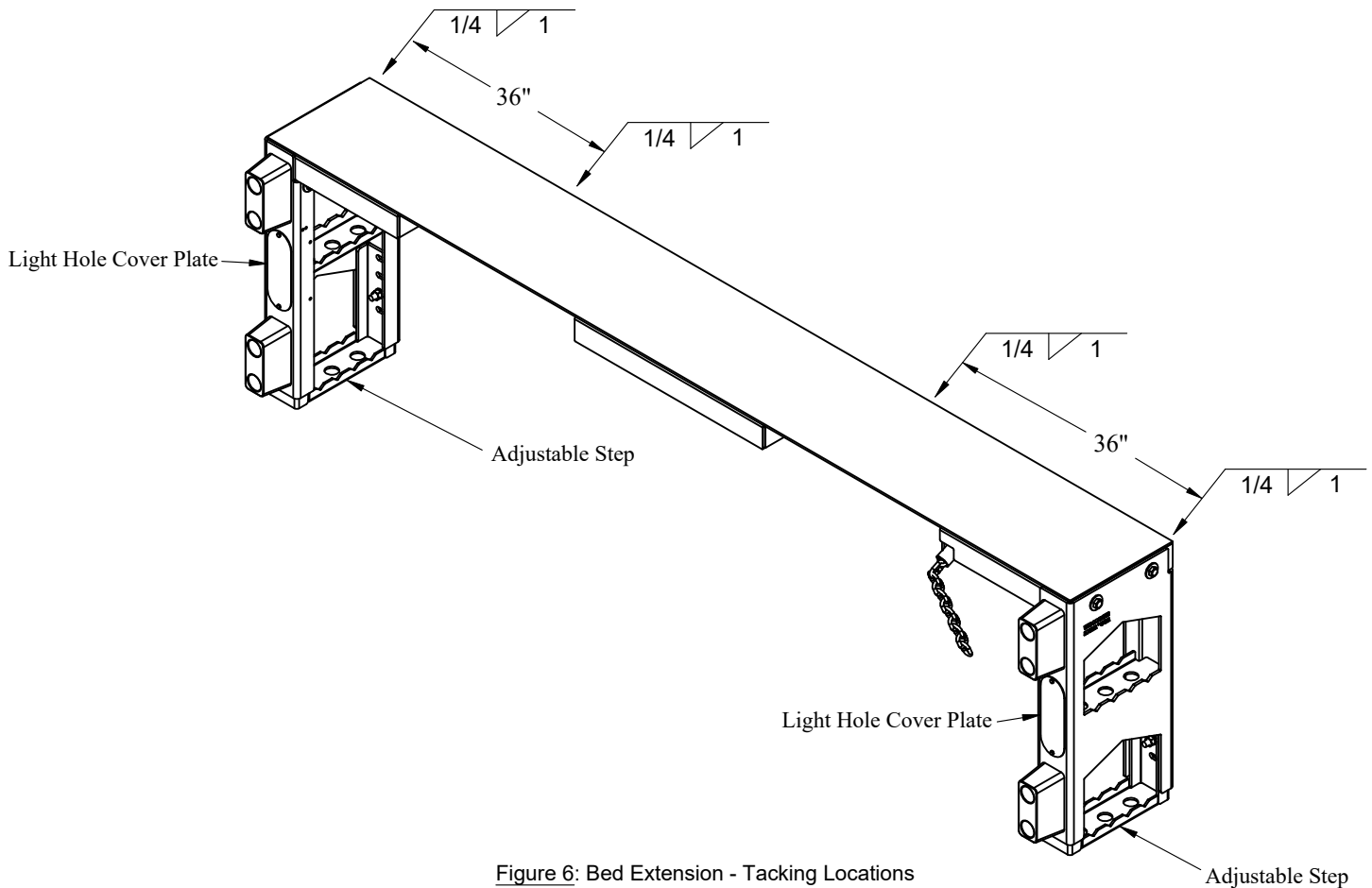

Figure 5: Frame trim dimensions.

Tuckunder Series Mounting Instructions

Positioning the Bed Extension on the Truck:

1. **Center** the bed extension on the rear of the body.
2. **Position** the bed extension against the body with the top surface flush with the body floor and level with the ground.
3. **Tack Weld** bed extension into position with four one inch welds (Figure 6).
Attach the bed extension with 1/2" hardware if exclusively bolting on for attachment.
4. **Verify** that the top surface of the bed extension is level.



Tuckunder Series Mounting Instructions

Positioning the Liftgate on the Truck

1. **Remove** packaging fastening gate to pallet except for the bands fastening the large trunnion tube to the pallet.
2. **Attach** 12 volts from a battery to the liftgate power cables (no battery chargers).
The negative cable is designated with a black stripe.
3. **Power** the control on.
4. **Raise** the liftgate using toggle switch to make sure liftgate is completely raised into the tagged cylinder stops (Figure 9).
The purpose of this step is to ensure there is no slack in the mechanism and the platform reaches bed height in the following mounting procedure.
5. **Power** the control off and **Disconnect** battery.

CAUTION: The platform will be heavy in the next step without the torsion springs engaged.

6. **Unfold** the platform.
7. If using a fork lift, **Position** the lift as shown (Figure 7).
Attach the platform to the forks using C-clamps with wood blocks to provide support and prevent damage to the platform edge.
8. **Remove** the two straps attaching the liftgate trunnion tube to the pallet.
9. **Lift** the liftgate with a forklift or overhead lift (Figure 7 or Figure 8).
10. **Verify** that the platform is fully rotated against the platform shims and there is no gap (Figure 9).

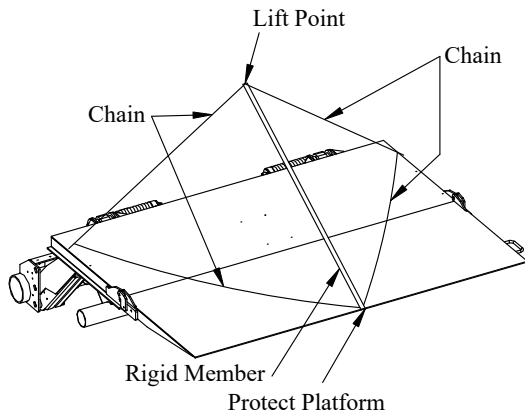
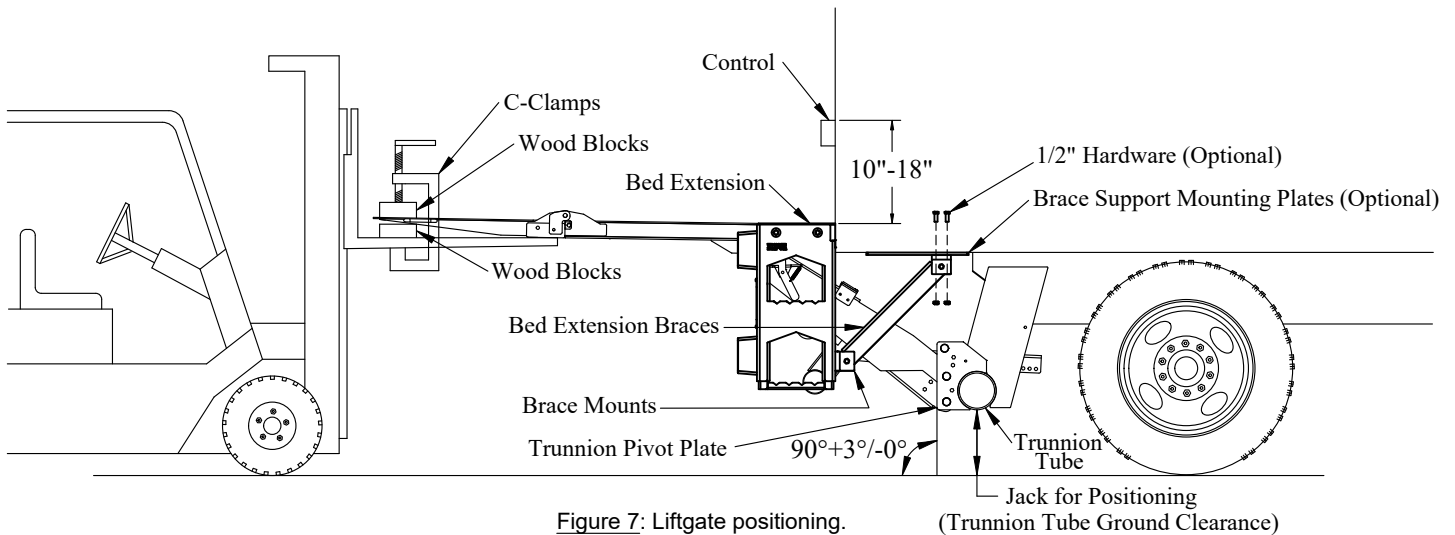

Figure 8: Liftgate positioning with overhead lift.

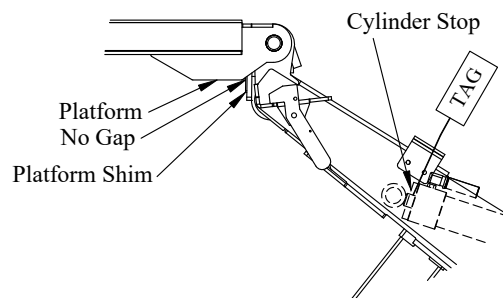

Figure 9: Platform shim & cylinder stop.

Tuckunder Series Mounting Instructions

Positioning the Liftgate on the Truck (continued)

- 11. Position** the liftgate platform against the rear of the bed extension, centered and flush with the top surface.
Note: The platform will be about 3/16" below the top surface of a heavy duty bed extension.

Note: A minimum of 15" of trunnion tube ground clearance is required when the truck suspension is loaded.
This is to allow the platform tilting mechanism to operate properly.

- For 50" platforms on trucks with less than 45" of loaded bed height:
Operate the liftgate lowering function to obtain 16"-17" between the trunnion tube and ground.
For 60" platforms with 45" or more of loaded bed height:
Proceed to the next step.

Note: The trunnion pivot plates will be square with the ground or the top tilted toward the front of the truck (Figure 7).

- 13. Position** the liftgate so that the the platform taper is 2" higher than the rear edge near the truck body.

Note: When using a forklift, tilt the mast to achieve the best position possible before using a jack.

- 14. Place** a jack under the trunnion tube to aid in positioning the liftgate (Figure 7). Do not apply too much pressure with jack, it will introduce slack into the mechanism.
- 15. Prepare** the mounting surfaces of the truck frame for welding. The surfaces should be free of paint and excess rust.
- 16. Position** the trunnion tube mounting plates on the trunnion tube outside of the truck frame (Figure 14).
- 17. Tack Weld** the trunnion tube mounting plates to the trunnion tube and truck frame using 3/8" fillet welds, 1" long (Figure 14).
Tack in locations A-E shown in diagram. Galvanized units will already be welded in location B.
- 18. Remove** the forklift or over head lift.

Tuckunder Series Mounting Instructions

Positioning the Liftgate on the Truck (continued)

19. **Remove** the 3/8" bolt, washers, nut, and washer plate from each lift arm (Figure 10).
20. Carefully **Lower** the platform, checking for proper operation and that the taper comes to within 1/2" of the ground.
21. **Move** the upper arm tube assembly to the alternate mounting holes if it contacts the ground. (Figure 11).
This may only be required on trucks with low bed heights.
22. **Remove** the tagged cylinder stops from each cylinder (Figures 9 & 12).
This must be done with the gate lowered.

CAUTION: The platform will be heavy in the next step without the torsion springs wound.

23. **Fold** the folding extension and main platform.
24. **Raise** the liftgate into stowed position, checking for clearance between platform and truck frame.
25. **Install** a 3/8" x 3-1/2" hex head bolt and lock nut in each coil spring holder (Figure 11). The platform must be in the stowed position so that the springs will engage as the platform is lowered.
26. **Open and Close** platform several times, checking adjustment of roller arm (Figure 13).
Extend the position of the arm to make opening the platform easier. A platform position of five to ten degrees short of vertical is recommended.

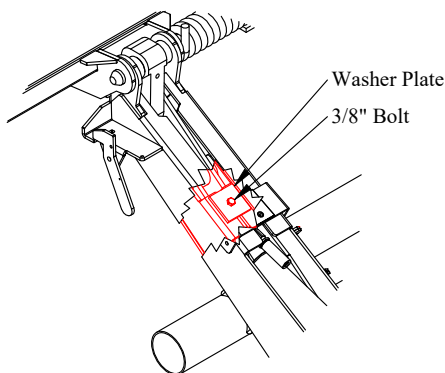

Figure 10: Washer plate location.

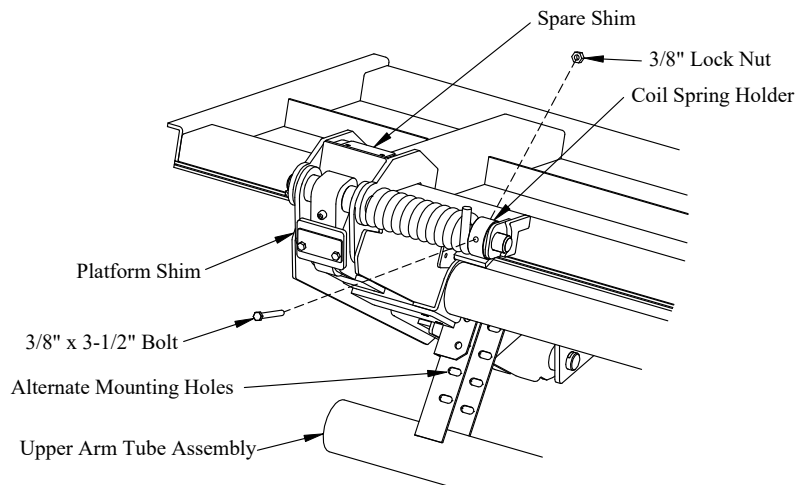

Figure 11: Platform springs and shims.

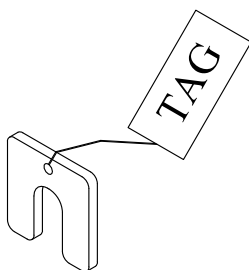

Figure 12: Cylinder stop with tag.

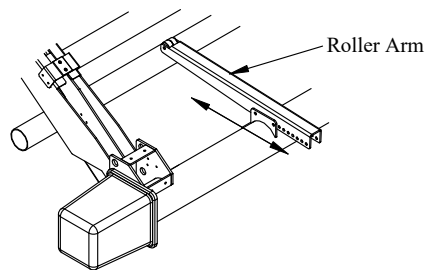

Figure 13: Roller arm adjustment.

Tuckunder Series Mounting Instructions

Finish Welding & Snubber Kit

1. **Cover** and **Protect** hydraulic hoses, wiring, and painted surfaces from welding heat and sparks in the next steps.
2. **Finish Weld** the trunnion tube mounting plates to trunnion tube and truck frame with 3/8" fillets (Figure 14).
3. **Finish Weld** the bed extension with 1/4" fillet welds (Figure 16).
Do not complete this step if the bed extension is to be exclusively bolted on.
4. **Weld** the snubber kit in position so that the platform will compress the rubber pads 1/4" when the platform is stowed (Figure 15).

Note: Place welds A - E on both trunnion tube plates.

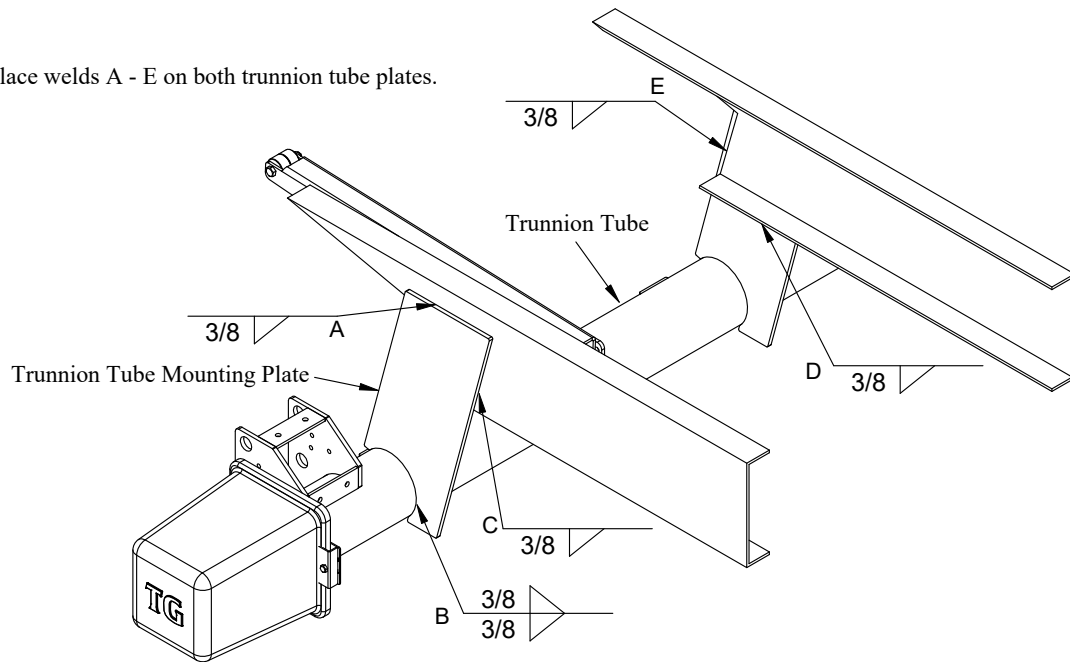

Figure 14: Trunnion Tube & Trunnion Tube Mounting Plates - Finish Weld Locations

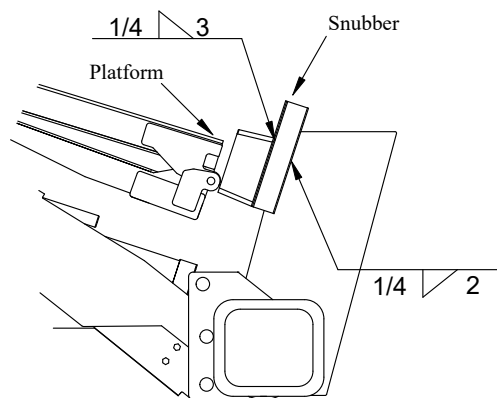

Figure 15: Snubber Kit - Finish Weld Location.

Tuckunder Series Mounting Instructions

Finish Welding the Liftgate on the Truck (continued)

Note: The deck extension can be installed using hardware only or a combination of hardware and weld. Use the optional Brace Support Mounting Plates and optional 1/2" hardware if it is needed for your application.

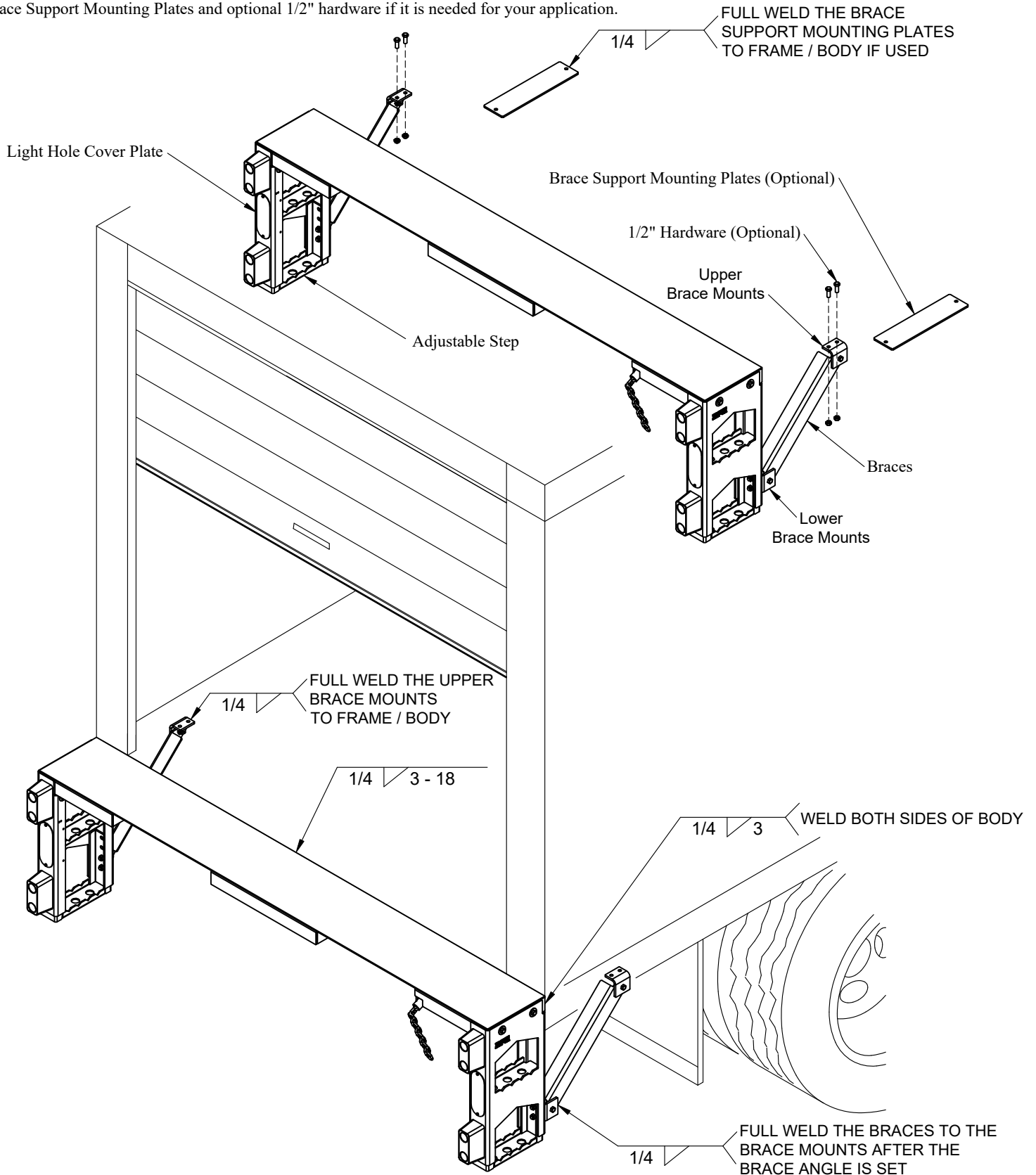

Figure 16: Bed Extension - Finish Weld Locations

Tuckunder Series Mounting Instructions

Finishing Gate Installation

1. **Adjust** the bottom step height. Minimum height for the bottom step is 15". Maximum is 25".
2. **Attach** the lower brace mounts to the bed extension steps with the supplied 1/2" bolts and lock nuts (Figure 16).
3. **Attach** the braces and upper brace mounts to the lower brace mounts with the supplied 1/2" bolts and lock nuts (Figure 16).
4. **Position** the upper brace mounts under the body floor (Figure 16).
The optional brace support mounting plates may be needed to provide structure for attachment.
5. **Weld** the upper brace mounts into position (Figure 16).
Use the optional 1/2" hardware to attach the upper brace mounts if it is not getting welded.
6. **Weld** the braces into position (Figure 16).
7. **Verify** that all bolted joints on the on the deck extension, brace mounts, and braces are tight.
8. **Route** the control wire from the pump box to mounting location on the rear of the truck (Figure 7).
9. **Position** and **Attach** the control box on the rear of the truck using the supplied paper template (Figure 7).
10. **Verify** proper latch chain operation (Figure 17).
11. **Verify** that the vent plug is installed in the pump reservoir (Figure 18).

Note: The hydraulic system has already been filled with the proper amount of hydraulic oil so do not add any oil at this time.

12. **Install** the "Do's and Do Not's" decal in a highly visible area of the vehicle cab.
This decal is with the Owner's / Operator's Manual.

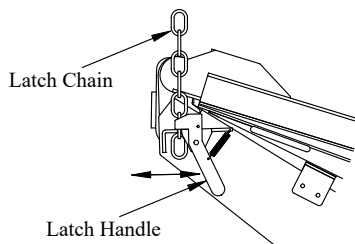

Figure 17: Platform latch chain.

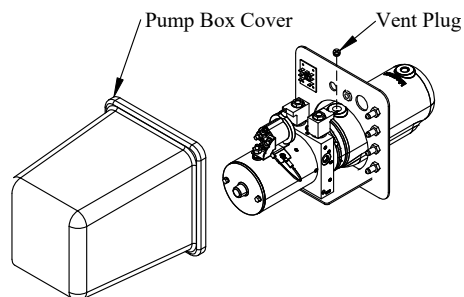

Figure 18: Pump reservoir vent plug.

Tuckunder Series Mounting Instructions

Routing the Power Cables

IMPORTANT: The liftgate is wired with a stub 4GA power cable for shipping purposes. This 4GA cable must be replaced with the correct 2GA cable during installation. Do not splice the 4GA and 2GA cables together.

1. **Attach** 12 volts from a battery to the liftgate power cables (no battery chargers). Red cable with black stripe is for ground.
2. **Lower** the liftgate to the ground.
3. **Remove** power to the liftgate.
4. **Remove** the short 4GA power cables attached to the power unit.
5. **Install** the 2GA power cable from the mounting kit on the power unit (Figure 18).
6. **Route** the power cables along the frame to the battery. Follow the *Tommy Gate Recommended Electrical Wiring Guidelines*.
7. **Install** the circuit breaker within 18" of the battery, leaving enough room for the power cables to be installed and so that the circuit breaker can easily be reset.
8. **Pull** the excess cable beyond the battery.
9. **Separate** the positive(+) and negative(-) leads.
10. **Cut** the positive(+) lead to the length required to reach the auxiliary (AUX) terminal of the circuit breaker.
11. **Cut** the remaining pos.(+) lead long enough to reach from the circuit breaker battery (BAT) terminal to the pos.(+) battery terminal.
12. **Cut** the negative(-) lead to the length required to reach the negative battery terminal.

CAUTION: The pump and motor unit for this lift can require significant electrical power at 12 volts D.C.
Be sure that the negative(-) ground lead is connected to the negative(-) terminal of the vehicle battery.

13. **Install** the copper lugs on all required ends.
14. **Connect** the circuit breaker and battery as outlined in the Tommy Gate Recommended Electrical Wiring Guidelines and wiring diagram (Figure 19).

ELECTRICAL WIRING DIAGRAM - Optional Pendant Control - Tuckunder

!!! PLEASE READ AND FOLLOW ALL DIRECTIONS BEFORE PROCEEDING !!!



NOTE !!! IF GATES ARE NOT WIRED IN ACCORDANCE WITH THIS DIAGRAM YOUR WARRANTY WILL BE VOID.



WELDING NOTE !!! DISCONNECT ALL BATTERY CABLES. ALWAYS DISCONNECT THE GROUND CABLE FIRST. ATTACH THE WELDING GROUND TO THE TRUCK RATHER THAN THE LIFTGATE.

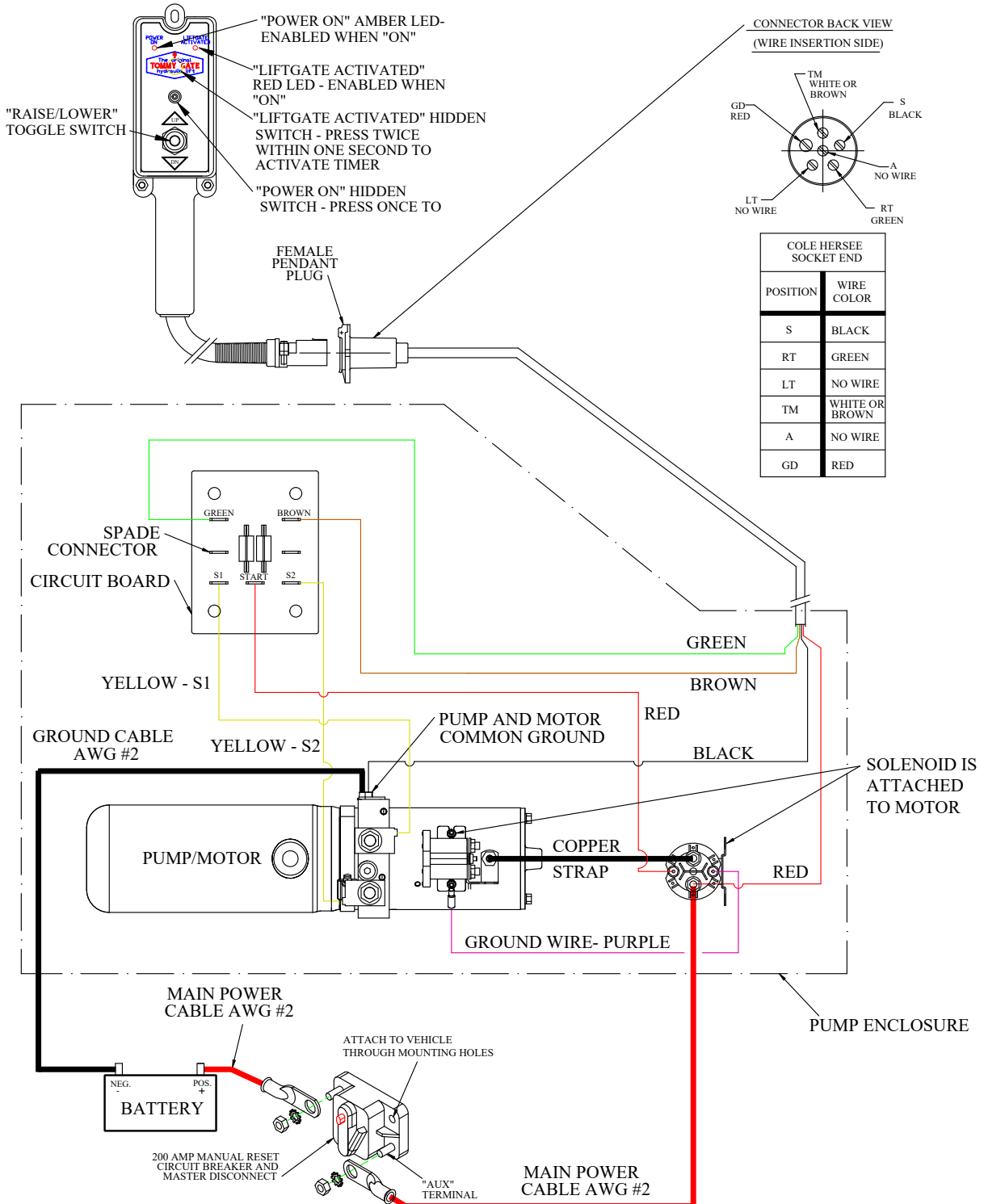
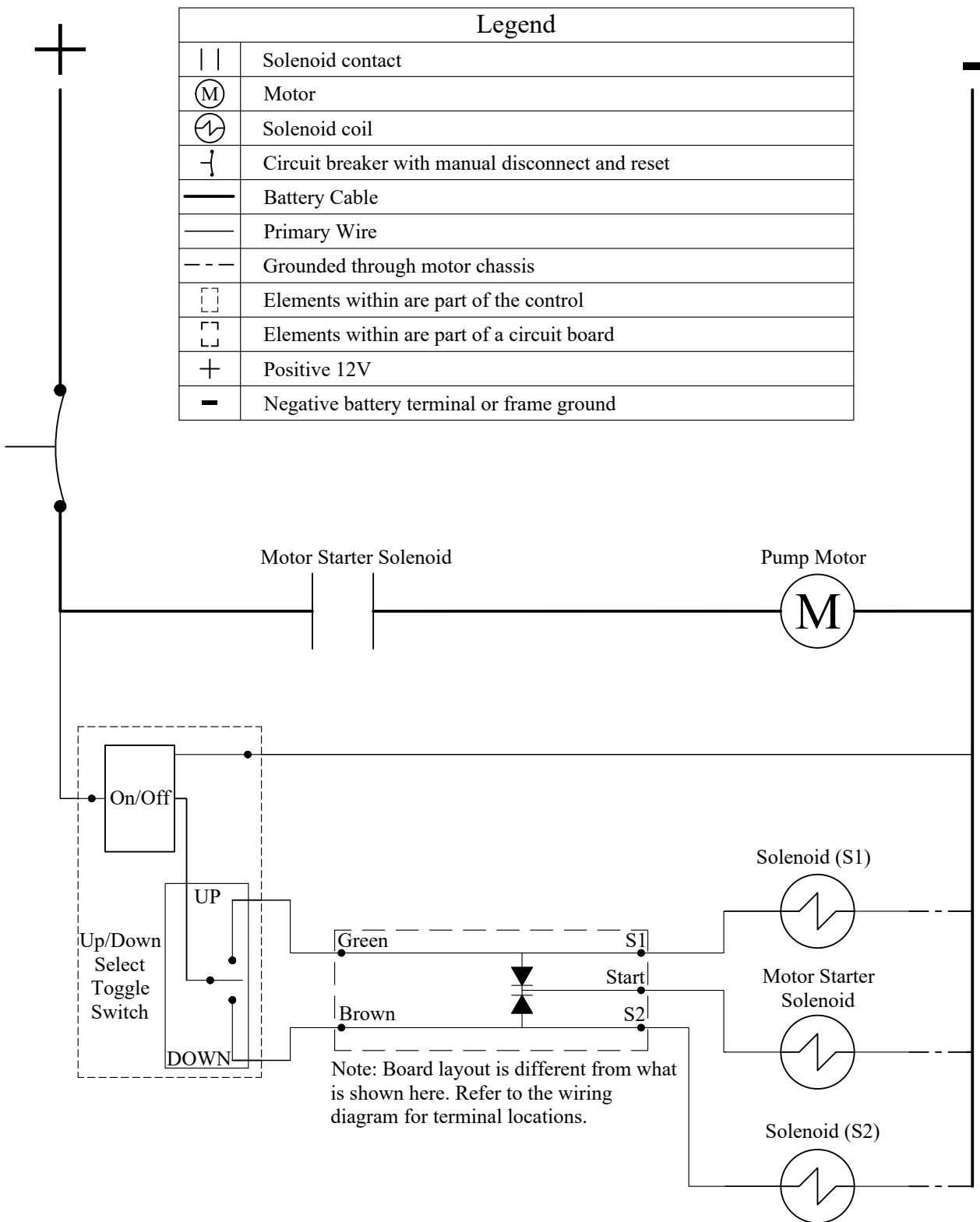

Figure 20: Optional Pendant Control Wiring diagram.

Tuckunder Power Unit Ladder Logic



Tuckunder Series Mounting Instructions

Tommy Gate Recommended Electrical Wiring Guidelines

WIRE ROUTING

1. When routing wires, avoid heat (above 180°F), abrasion, vibration, metal edges, screws, and trim fasteners. If such routings are not possible, protective devices must be used. If wires must cross a metal edge, the edge should be covered with a protective shield and the wiring fastened within 3 inches on each side of the edge.
2. Grommets must be used where wires pass through holes in sheet metal, castings, and / or frame rails. Do not bend wires in a radius smaller than 10 times the wire diameter.
3. Routing wires into areas exposed to wheel wash should be avoided. If this cannot be avoided protective shields are required to protect the wires from stones, ice, salt and water damage. Provide a drip loop to prevent moisture from being conducted into switches, relays, circuit breakers, and fuses.
4. Wires should be supported every 18 inches with plastic zip ties or rubber-lined clips.
5. Wires must be routed to clear moving parts by at least 3 inches unless positively fastened or protected by a conduit. If wiring must be routed between two members where relative motion can occur, the wiring should be secured to each member, with enough wire slack to allow flexing without damage to the wire.
6. Maintain at least a 6 inch clearance from exhaust system components. If this is not possible, high temperature insulation and heat shields are required. Existing OEM heat shields, insulation, and wire shielding must be maintained.
7. Do not route or attach electrical wires to fuel lines. Route electrical wires at least 1-1/2 inches away from the engine.

BATTERY, WIRE, TERMINALS, AND CONNECTORS

1. Wire attachments at the battery must be protected from tension loads so there is no undue strain on the battery terminals. Wires should be routed down rather than horizontally from the terminals with no sharp bends adjacent to the connections.
2. Battery power for your Tommy Gate should come directly from the battery through the supplied circuit breaker or fuse. The circuit breaker or fuse should be installed as close to the battery as possible.
3. Do Not splice battery cables. If splicing is necessary, the most durable splice joint will be bare metal barrel crimped, flow-soldered and covered with adhesive lined heat shrink tubing. Strip the wire ends making sure that individual conductor strands are not damaged. Use only rosin core solder, proper crimping tools, and wire with a gauge at least equivalent to the circuit being lengthened. Do not use electrical tape.
4. Battery cable terminals will be bare metal barrel crimped or flow-soldered and covered with adhesive lined heat shrink tubing.
5. Use wire connectors with locking features such as positive locking, inertia locking, bolt together, and soft mold-over with locking external retainers.

GENERAL

1. All frame contact areas must be wire brushed to bare metal, free of paint, dirt, and grease. Frame connections must be made using hardened flat washers under the bolt head and lock nuts. Corrosion preventive grease or compound is to be applied to the terminal area of the frame connection.
2. Frame cross members are not recommended as part of the ground return.
3. All circuit breakers and fuses should be located in one easily serviceable location with a means provided for identification of circuit function and current rating. Do not put circuit breakers or fuses in the vehicle cab.
4. Before welding to the chassis disconnect the battery. Also disconnect the power train, engine, valve, and transmission control modules.
5. Do not alter vehicle ignition, starting, and / or charging systems. Do not reroute engine compartment wiring.
6. Full copper circuitry and standardized polarity grounds are recommended.
7. Never increase the rating of a factory installed fuse or circuit breaker.
8. Disconnect the battery negative (ground) wire prior to any vehicle modification.

Following the above guidelines will provide you with years of trouble free service. Failing to incorporate the above guidelines will result in a voided warranty. Non-compliance with the guidelines above may result in a failure of electrical components, shutdown of engines, loss of backup brake systems, and the possibility of fire.

Tuckunder Series Mounting Instructions

Testing the Operation of the Liftgate

CAUTION: Keep all foreign objects (body parts, tools, load weights, etc) away from the liftgate main assembly and away from pinch points at all times when operating the liftgate.

1. **Check** operation of the safety control for proper lift operation.
Be sure the control shuts off automatically after 5 minutes (or 90 seconds for pendant control) of not being used .
2. **Raise** and **Lower** the unloaded platform on a flat surface looking for proper operating speed and alignment with the ground.
3. **Load** the platform with the rated capacity and **Measure** the time necessary to raise the platform.
The platform should raise at roughly 2-3 inches per second.
4. **Examine** the platform for any downward creep.
5. **Time** the lowering operation with the platform still loaded.
The platform should descend at roughly 4-7 inches per second.
6. **Remove** the load from the platform and examine the liftgate and vehicle for any problems such as hydraulic oil leaks, loose wiring, etc.
7. **Reinstall** the pump cover. Use the 3/8" lock nuts supplied in the mounting kit along with the 3/8" bolts that were removed previously.
8. **Close** and **Latch** the platform folding extension.
9. **Raise** and **Latch** the liftgate latch chain (Figure 21).
10. **Install** the padlock into the hole in the latch handle (Figure 21).
11. **Place** Owner's / Operator's Manual and padlock keys in the vehicle.

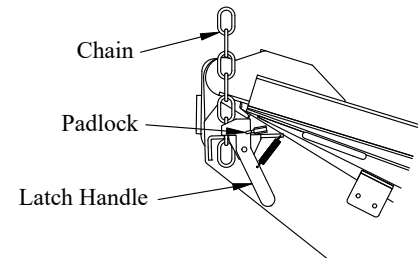

Figure 21: Chain latch and padlock location.

Painting the Liftgate (if needed)

Your Tommy Gate has been primed with a gray polyurethane and painted with a black semi-gloss polyurethane topcoat to protect it from the environment. No additional paint is required unless shipping or installation damage or outdoor storage exposure has deteriorated the Tommy Gate paint. **Tommy Gate will not be responsible for shipping or installation damage or outdoor storage exposure that has marred or otherwise deteriorated the Tommy Gate paint.**

If you need to refinish the liftgate you should do the following.

1. **Remove** any dirt, oil, grease, salt, or other contamination by washing with a mild detergent solution.
2. **Rinse** thoroughly with fresh water and allow to dry.
3. Lightly **Scuff Sand** the Tommy Gate topcoat.
4. **Sand** and **Spot Prime** any area of the Tommy Gate paint that shows signs of damage or deterioration.
5. **Mask** off all safety decals, cylinder shafts and vents before painting.

WARNING: Paint overspray on the cylinder shaft(s) or vent(s) will damage the cylinder seals and void warranty.

6. After proper cleaning and surface preparation, **Apply** desired finish coat per paint manufacturer's recommendations.
7. **Remove** the masking from the safety decals and cylinders.
8. **Check** to ensure that all decals are clean and legible. Additional decals are available from the factory, if needed.

Tuckunder Series Mounting Instructions

Platform Adjustment Instructions

If the platform is no longer at the desired angle with the ground, it may need adjustment. The following instructions will aid you in adjusting the platform angle.

1. **Unlock** and **Unlatch** the platform.
2. **Position** the liftgate so that the lift arms are touching the ground, but the platform is still folded (Figure 22).
3. **Support** the platform so that it cannot fall while performing the next step.

Note: The platform is intended to be approximately 2" higher at the taper to compensate for flex when loaded.

4. **Replace** or **Add** shims to the platform links (Figure 22).
Adding a 12GA (0.105") shim will raise the platform taper approximately 2-1/4".
5. **Unfold** the platform and folding extension.
6. **Verify** that the angle of the platform is acceptable.
7. **Store** and **Lock** the liftgate.

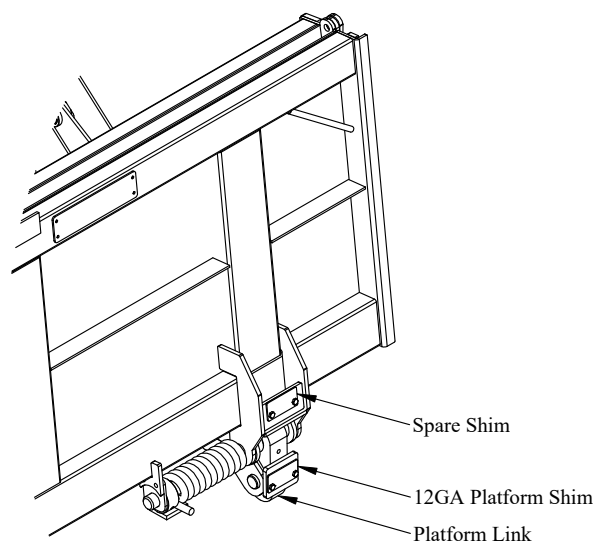

Figure 22: Platform shim location.

Tuckunder Series Mounting Instructions

Operator's Instructions

1. Never show children or unauthorized personnel how to operate the liftgate.
2. Clear away obstructions that could damage the platform while the load is being raised or lowered.
3. Do not ride on the Platform. Be sure to stand to the side of the lift, not behind it when opening the platform.
4. To turn the control power on, press the "POWER ON" hidden switch once, marked with white rings or circles (located below the Tommy Gate logo). You should see the amber LED "POWER ON" light when the control is armed. To disarm the control press the "POWER ON" hidden switch again. Terms used for the control are shown in (Figure 23).

To activate the control, press the "LIFTGATE ACTIVATED" hidden switch twice within one second (located under the Tommy Gate logo). You should see the red "LIFTGATE ACTIVATED" light when the control is activated. To lower the platform, push the control toggle switch down. To raise the platform, push the control toggle switch up. When you remove pressure from the control toggle switch, the operation will stop.

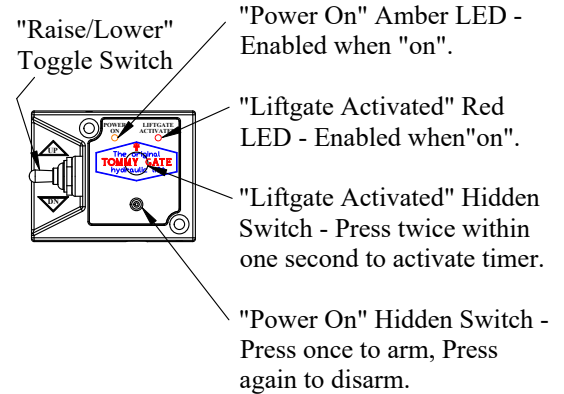

Figure 23: Control terms.

After you have activated the control by pressing the "LIFTGATE ACTIVATED" hidden switch twice within one second (located under the Tommy Gate logo), you have approximately 5 minutes to use the gate. If the gate is not used for approximately 5 minutes, the "LIFTGATE ACTIVATED" time deactivates the control.

If the gate is used during the 5 minutes, the "LIFTGATE ACTIVATED" timer automatically resets for an additional 5 minutes. To reactivate the timer, press the "LIFTGATE ACTIVATED" hidden button twice.

Note: If your gate includes a pendant control, the operation of the pendant will be the same but the "LIFTGATE ACTIVATED" timer will be 90 seconds.

5. Unlock and remove the latch padlock (Figure 24).
6. Pull the latch handle away from the truck to disengage the latch. With the other hand, disengage the chain from the latch (Figure 24).
7. To lower the liftgate, stand off to the side, well clear of the liftgate, and push down on the control toggle. The platform will rotate under the truck as the liftgate is lowered.
8. With the liftgate arms touching the ground, stand off to the side, and unfold the platform (Figure 25).

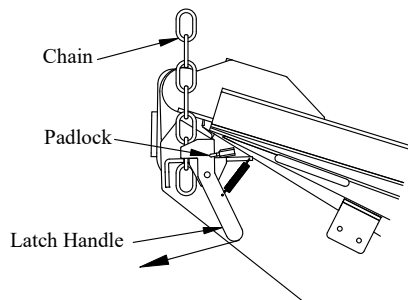

Figure 24: Step 5.

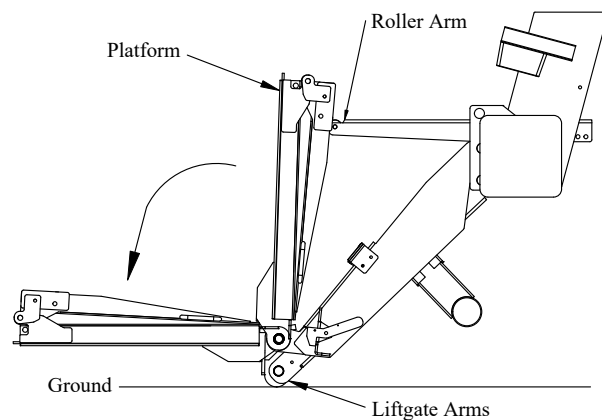

Figure 25: Step 8.

Tuckunder Series Mounting Instructions

Operator's Instructions (continued)

9. **Stand off** to the side and unfold the platform folding extension (Figure 26).
10. **To lower** the platform to the ground push down on the control toggle. The platform will lower and the taper will tilt until the platform taper touches the ground (Figure 27).
11. **To load** and use the liftgate, center the load on the platform side to side and front to back (Figure 28). Put heavier loads as close to the front of the platform as possible (near truck). Platform cart stops may be actuated at this time, if equipped.

Note: Liftgate capacity depends on both the weight and location of the load. Loads placed closer to the taper may reduce lifting capacity or damage the liftgate.

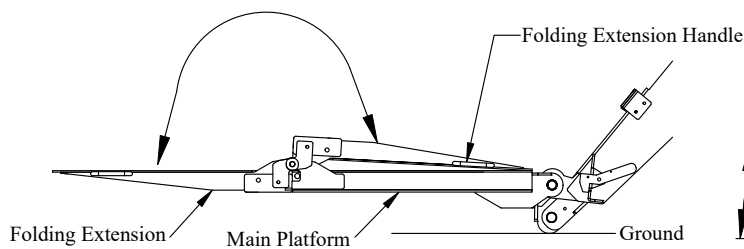

Figure 26: Steps 9 and 13.

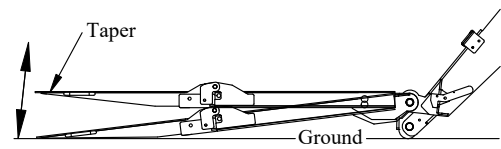

Figure 27: Step 10.

12. **To raise** (or lower) the load, stand off to the side, well clear of the platform and push up (or down) on the control toggle switch until the load has reached the desired position. Do not allow the pump and motor to continue to run after the platform has reached its maximum height or after it has reached an obstruction.
13. **To close** the platform, stand to the side of the platform, not under or behind the platform. With the liftgate lowered, close and lock the platform cart stops, if so equipped, then fold the folding extension by lifting on the handle (Figure 26).
14. **With** the liftgate arms touching the ground, stand to the side of the platform, and fold the platform closed until it rests on the roller arm (Figure 29).
15. **Raise** the liftgate by pushing up on the control toggle. The platform will rotate under the truck into the stowed position.
16. **Latch** the liftgate by pulling on the latch lever, engaging the latch chain into the latch, and then releasing the latch lever (Figure 30).
17. **Always** install the padlock on the latch and deactivate the control when not in use (Figure 30).

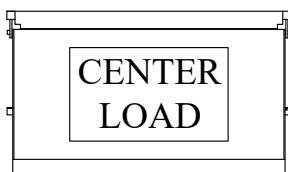

Figure 28: Step 11.

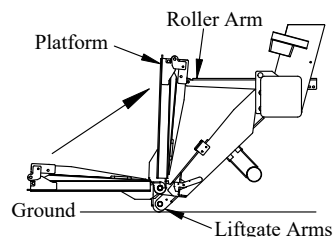

Figure 29: Step 14.

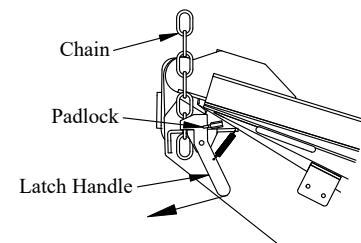

Figure 30: Steps 16 and 17.

Tuckunder Series Mounting Instructions

Attaching Flags to Platform

1. **Verify** Reflective Tommy Gate Flags Kit (Figure 31 and Table 3).

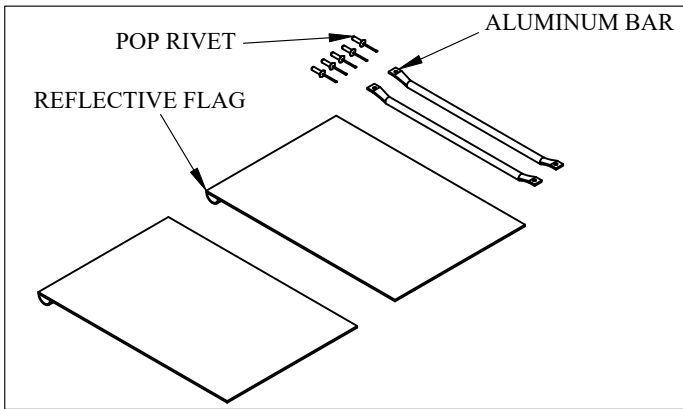

Table 3: Parts list for kit PN016925.

| QTY. | PART NO. | DESCRIPTION |
|------|----------|-----------------------------------|
| 2 | 016922 | ALUMINUM BAR |
| 2 | 016923 | TOMMY GATE REFLECTIVE FLAG |
| 5 | 016924 | 0.1875"x0.575" ALUMINUM POP RIVET |

Figure 31: Reflective Tommy Gate Flags Kit.

2. **Insert** the aluminum bar into the reflective flag.

3. **Select** a location for the reflective flags that does not obstruct the license plate:

- If your liftgate has the Tommy Gate license plate or other kit installed outside of the mounting brackets, use the four (4) holes indicated as "A" on Figure 32.
- If your liftgate has license plate installed inside of the mounting plates, use the four (4) holes indicated as "B" on Figure 32.

4. **Verify** the Tommy Gate logo facing the platform and the blank side facing up (Figure 32). Reflective side shall face the taper end of the platform when liftgate is deployed.

5. **Rivet** the aluminum bar to the platform using the provided rivets.

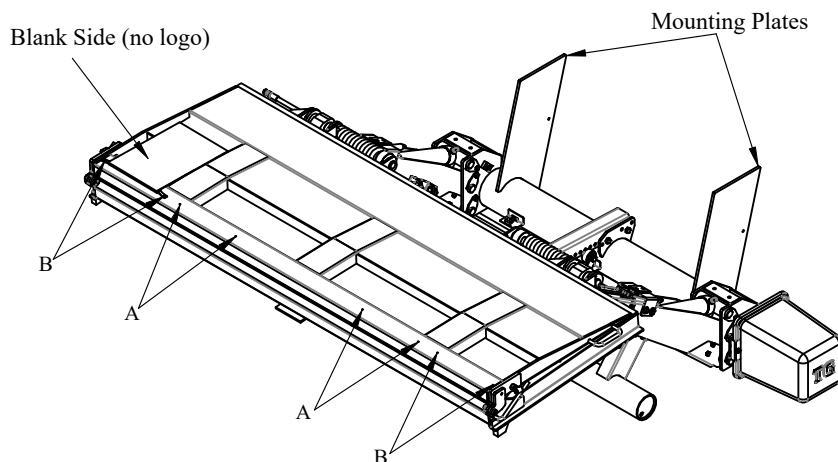

Figure 32: Platform Reflective Flags.
(Aluminum platform may have a different representation, hole position remains the same.)