

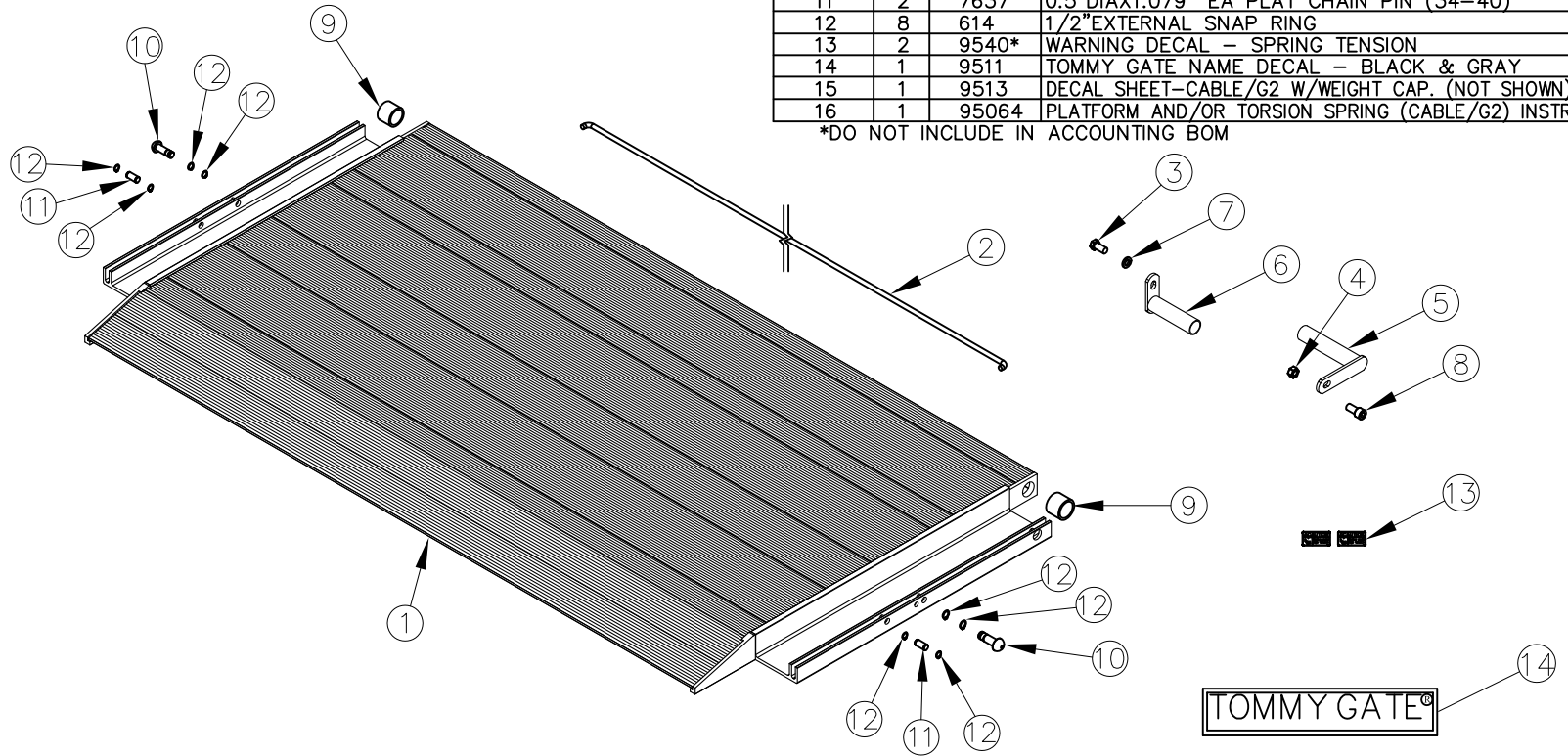

| ITEM NO. | QTY. | PART NO. | DESCRIPTION |
|----------|------|----------|--|
| 1 | 1 | 3409 | 72 EA PLATFORM COMPLETE |
| 2 | 1 | 7871 | .375"x70.563" TORSION SPRING(72EA) |
| 3 | 1 | 587 | 1/2-13x1" HHCS GR5 |
| 4 | 1 | 588 | 1/2-13 CROWN LOCK NUT |
| 5 | 1 | 7710 | HINGE TUBE SPRING HOLDER-46EA PASS |
| 6 | 1 | 7778 | HINGE TUBE SPRING HOLDER-EA DRIVER |
| 7 | 1 | 573 | 1/2" SPRING LOCKWASHER |
| 8 | 1 | 604 | 1/2-13x1"USS SOC HD CAP STAINLESS |
| 9 | 2 | 8919 | 9/16"x1.38" I.D.x1.66" O.D.x.140" AL TUBING |
| 10 | 2 | 7715 | 0.5"DIA X 1.5" SS EA PLAT LATCH PIN (34-40) |
| 11 | 2 | 7637 | 0.5"DIA X 1.079" EA PLAT CHAIN PIN (34-40) |
| 12 | 8 | 614 | 1/2" EXTERNAL SNAP RING |
| 13 | 2 | 9540* | WARNING DECAL - SPRING TENSION |
| 14 | 1 | 9511 | TOMMY GATE NAME DECAL - BLACK & GRAY |
| 15 | 1 | 9513 | DECAL SHEET-CABLE/G2 W/WEIGHT CAP. (NOT SHOWN) |
| 16 | 1 | 95064 | PLATFORM AND/OR TORSION SPRING (CABLE/G2) INSTR. |

*DO NOT INCLUDE IN ACCOUNTING BOM



NOTES: APPLY DECALS FROM 9513 SHEET SAME AS PRODUCTION
SEND (2) 9540 LOOSE

| REV. | DATE | CHANGE RECORD | BY | APPVD | ECN | THIRD ANGLE PROJECTION | | | FILENAME: | | WOODBINE MFG. CO. BUS BROWN DRIVE WOODBINE, IOWA 51579 | | |
|------|----------|---|-----|-------|------|---------------------------|-------------|------|------------------------|----------------------------------|---|----------|---------------|
| | | | | | | DECIMAL | 2PLC | 3PLC | SYMBOLY PER ANSI Y14.5 | NOTES: | | | |
| D | 9/30/16 | ADDED (1) 9511, (1) 9513, (1) 95064 | AAS | | 1709 | MACHINE SAW, DRILL | .030 | .015 | DRAWN BY. DJR | |  THE INFORMATION HERE IS CONFIDENTIAL AND MUST NOT BE USED IN ANYWAY DETRIMENTAL TO THE INTEREST OF WOODBINE MFG. | | |
| C | 11/15/10 | ADDED (2) 9540 | JCB | | 367 | SHEAR, PUNCH FORM | .060 | .030 | DRAWN/DATE 8/19/04 | | | | |
| B | 7/12/10 | REPLACED KITS WITH INDIVIDUAL PARTS; REPLACED (1) 8920 W/ (1) 8919 | JCB | | 276 | TORCH, WELDING ROUGH CAST | .090 | .060 | APPVD/DATE | TITLE 72 EA REPLACEMENT PLATFORM | | | |
| | | | | | | DRAFT 2' | ANGULAR ±1' | | SALES CATEGORY | PRODUCT LINE | SCALE 1:15 | FIN. WT. | PART NO. 1639 |