

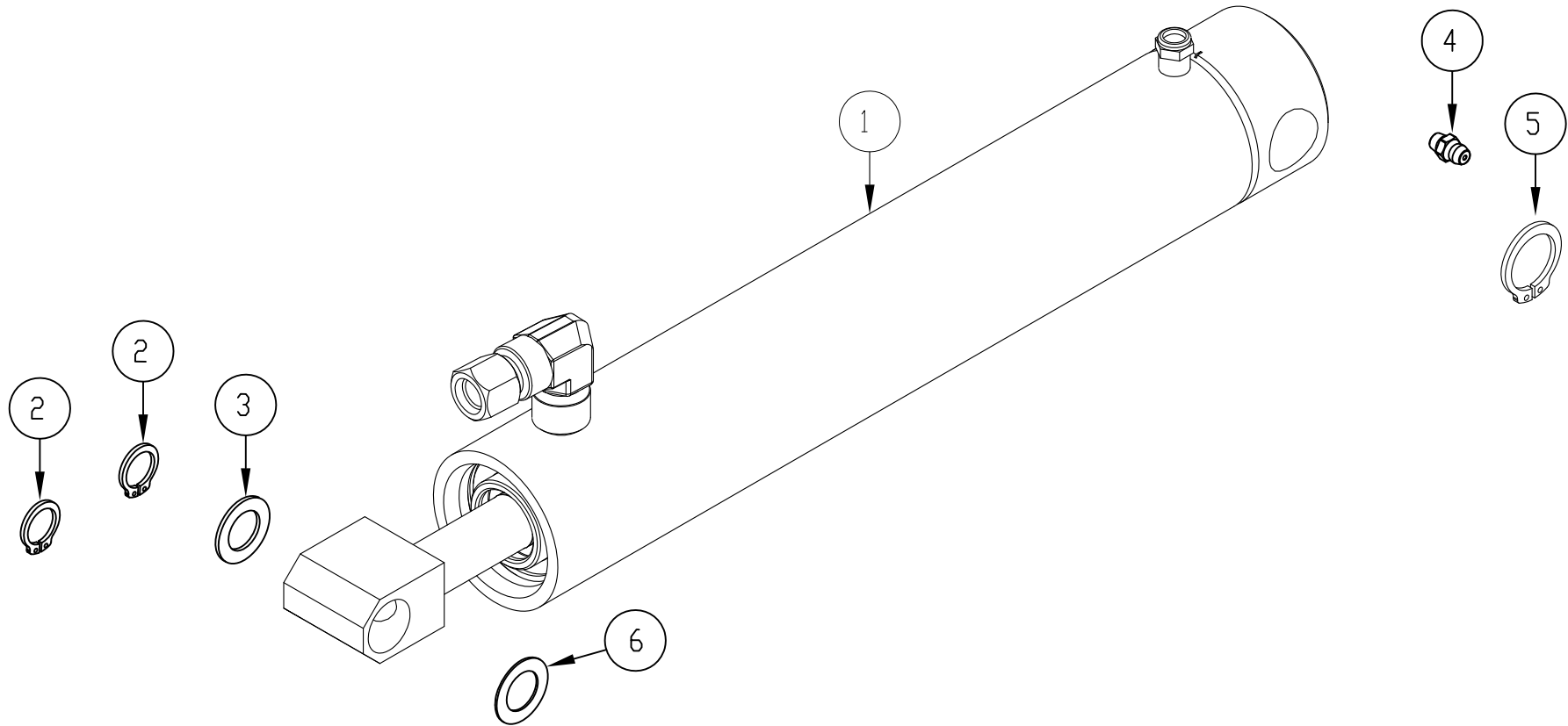

ITEM NO.	QTY.	PART NO.	DESCRIPTION
1	1	2112	G2 CYLINDER COMPLETE
2	2	2025	3/4" EXTERNAL SNAP RING
3	1	622	3/4"IDx1-1/4"O.D. FLAT WASHER
4	1	4746	1/4-28 STRAIGHT FITTING ZERK (SHORT)
5	1	2026	7/8" EXTERNAL SNAP RING
6	1	10976	3/4"IDx1-1/4"O.D. THIN FLAT WASHER
7	1	95007	G2 CYLINDER REPLACEMENT INSTR.

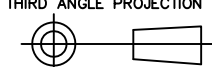

REV.	DATE	CHANGE RECORD	BY	APPVD	ECN	DRAFT 2'	ANGULAR ±1'	SALES CATEGORY	PRODUCT LINE	SCALE N	FIN. WT. 9.8	PART NO. 971	
F	4/11/16	REMOVED 9472	AAS		1614	THIRD ANGLE PROJECTION  DECIMAL MACHINE SAW, DRILL SHEAR, PUNCH FORM TORCH, WELDING ROUGH CAST DRAFT 2' ANGULAR ±1'		FILENAME:	WOODBINE MFG. CO. BUS BROWN DRIVE WOODBINE, IOWA 51579  THE INFORMATION HERE IS CONFIDENTIAL AND MUST NOT BE USED IN ANYWAY DETRIMENTAL TO THE INTEREST OF WOODBINE MFG.				
E	1/21/11	ADDED (1) 10976	JCB		381			SYMBOLY PER ANSI Y14.5					NOTES:
D	5/28/09	ADDED PN2026	LSB	LSB			2PLC .030	3PLC .015					DRAWN BY. MTC
C	8/29/08	ADDED PN9472 AND PN95007	MTC	MTC			.060	.030					DRAWN/DATE 02/28/06
B	7/2/08	ADDED GREASE ZERK TO BOM	KGJ	KGJ			.090	.060					APPVD/DATE