

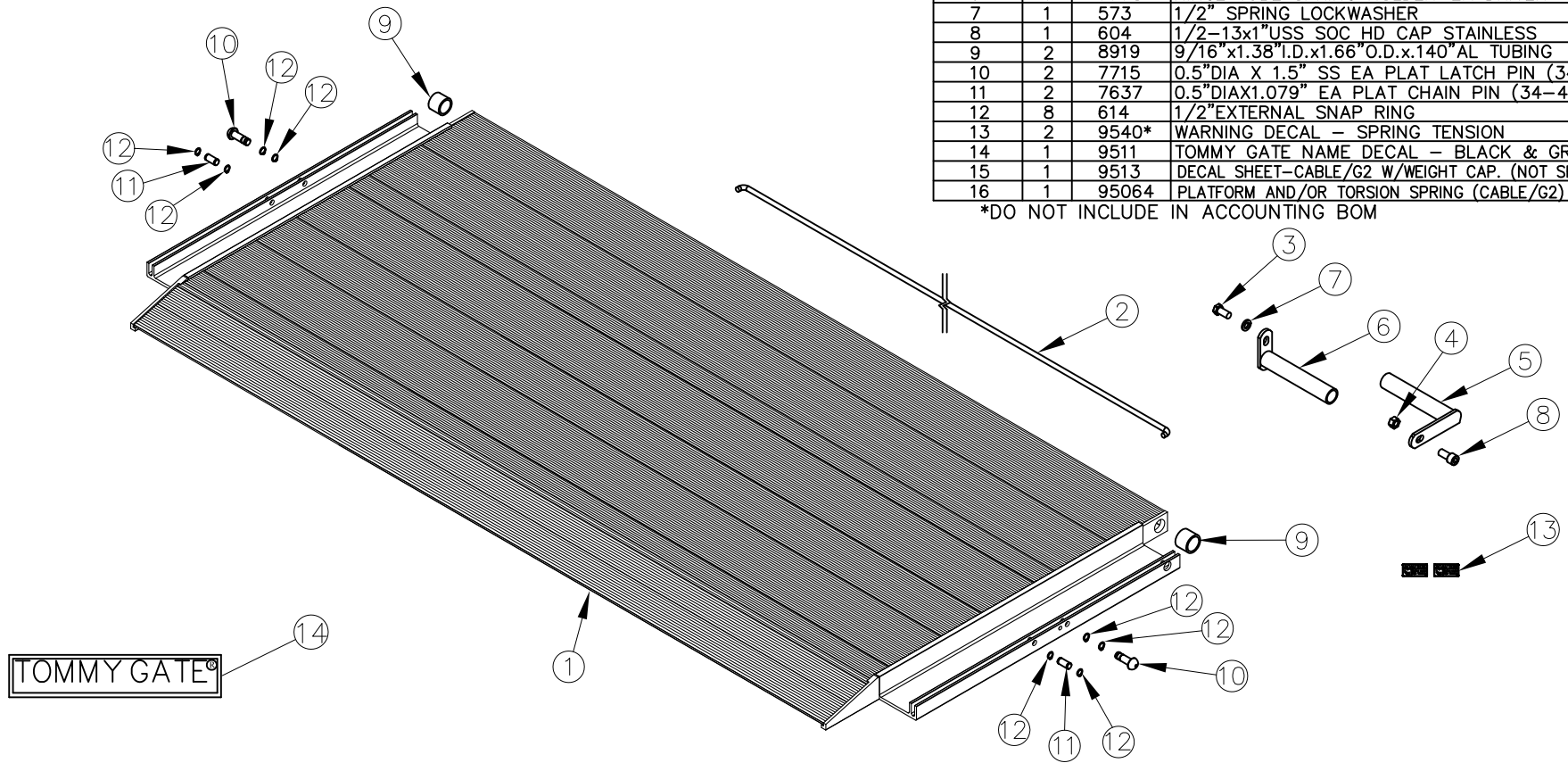

ITEM NO.	QTY.	PART NO.	DESCRIPTION
1	1	3305	EA PLATFORM COMPLETE (91-50) 42+6"
2	1	7874	0.375 X 89.563 SPRING (91 EA)
3	1	587	1/2-13x1" HHCS GR5
4	1	588	1/2-13 CROWN LOCK NUT
5	1	7710	HINGE TUBE SPRING HOLDER-46EA PASS
6	1	7778	HINGE TUBE SPRING HOLDER-EA DRIVER
7	1	573	1/2" SPRING LOCKWASHER
8	1	604	1/2-13x1"USS SOC HD CAP STAINLESS
9	2	8919	9/16"x1.38" I.D.x1.66" O.D.x.140" AL TUBING
10	2	7715	0.5"DIA X 1.5" SS EA PLAT LATCH PIN (34-40)
11	2	7637	0.5"DIA X 1.079" EA PLAT CHAIN PIN (34-40)
12	8	614	1/2" EXTERNAL SNAP RING
13	2	9540*	WARNING DECAL - SPRING TENSION
14	1	9511	TOMMY GATE NAME DECAL - BLACK & GRAY
15	1	9513	DECAL SHEET-CABLE/G2 W/WEIGHT CAP. (NOT SHOWN)
16	1	95064	PLATFORM AND/OR TORSION SPRING (CABLE/G2) INSTR.

*DO NOT INCLUDE IN ACCOUNTING BOM

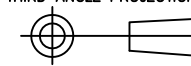

NOTES: APPLY DECALS FROM 9513 SHEET SAME AS PRODUCTION
SEND (2) 9540 LOOSE

REV.	DATE	CHANGE RECORD	BY	APPVD	ECN	DRAFT	ANGULAR	SALES CATEGORY	PRODUCT LINE	SCALE	FIN. WT.	PART NO.		
D	9/30/16	ADDED (1) 9511, (1) 9513, (1) 95064	AAS		1709	2'	±1'							
C	11/15/10	ADDED (2) 9540	JCB		367									
B	7/12/10	REPLACED KITS WITH INDIVIDUAL PARTS; REPLACED (1) 8920 W/ (1) 8919	JCB		276									
A	4/21/08	DRAWN IN AUTOCAD	JCB	KGJ										
						THIRD ANGLE PROJECTION		FILENAME:		WOODBINE MFG. CO. BUS BROWN DRIVE WOODBINE, IOWA 51579  THE INFORMATION HERE IS CONFIDENTIAL AND MUST NOT BE USED IN ANYWAY DETRIMENTAL TO THE INTEREST OF WOODBINE MFG.				
						 DECIMAL 2PLC 3PLC MACHINE SAW, DRILL .030 .015 SHEAR, PUNCH FORM .060 .030 TORCH, WELDING ROUGH CAST .090 .060		SYMBOLY PER ANSI Y14.5					NOTES:	
								DRAWN BY: JCB						
								DRAWN/DATE: 4/21/08						
								APPVD/DATE:		TITLE: 91 EA REPLACEMENT PLATFORM 42+6"				
								SALES CATEGORY:		PRODUCT LINE:		SCALE: 1:15	PART NO. 1224	