



Woodbine, Iowa



# OWNER'S / OPERATOR'S MANUAL

- Safety Information
- Warranty Information
- Operator's Instructions
- Maintenance Instructions
- Parts List

## V2 Series 1100 LB Capacity

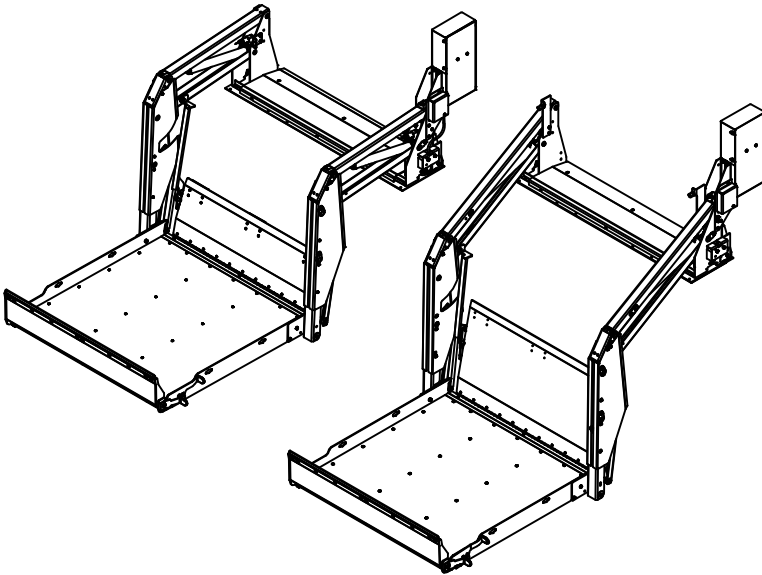

Mounting kits for V2 liftgates are intended for the specified vehicle model only. Use of a mounting kit in a vehicle or manner other than intended is **NOT** recommended by Tommy Gate. Using an incorrect mounting kit will likely result in damage to the van's bumper, door and floor area, as well as to the lifting and folding mechanism of the liftgate.



Before installing or using this Liftgate, please observe the Vehicle Loading Limitations. These loading limitations are outlined in the Vehicle Owner's Manual and the Safety Compliance Certification Label located on the drivers door pillar.



PLEASE KEEP IN VEHICLE



# TABLE OF CONTENTS

<b><u>Introduction</u></b>	<b><u>Page#</u></b>
To the Owner\Operator -----	3
 <b><u>Safety Decals</u></b>	
Location and Descriptions -----	4-6
Decal Replacement -----	6
 <b><u>Operator's Instructions</u></b>	
Terms and Method of Operation -----	7
Operator's Instructions -----	8-10
 <b><u>Electrical Wiring Diagrams</u></b>	
Standard Pendant Control -----	11
V2 Power Unit Control Circuit -----	12
 <b><u>Maintenance and Service</u></b> ----- 13	
Platform and Threshold Bridge Adjustments -----	14-16
 <b><u>Troubleshooting</u></b> ----- 17-18	
 <b><u>Warranty</u></b>	
Standard Warranty -----	19
Warranty Claims Handling Procedure -----	20
 <b><u>Repair Parts List</u></b>	
Repair Parts Drawing -----	21
Repair Parts List -----	22
 <b><u>Service Records</u></b> ----- 23	
 <b><u>Contact Information</u></b> ----- 24	



## TO THE OWNER\OPERATOR

Read this manual completely before using your gate. Operate and maintain your gate safely as outlined in this manual. Be sure you read and understand all operating, safety, maintenance and service information. Should you need repair or service information, contact Tommy Gate or an authorized distributor for assistance.



This is the safety alert symbol. It is used to alert you to potential personal injury hazards. Obey all safety messages that follow this symbol to avoid possible injury or death.



DANGER indicates an imminently hazardous situation which, if not avoided, will result in death or serious injury.



WARNING indicates a potentially hazardous situation which, if not avoided, could result in death or serious injury.



CAUTION indicates a potentially hazardous situation which, if not avoided, may result in minor or moderate injury.

Safety is a primary concern in the design and manufacture of our products. Unfortunately, our efforts to provide safe equipment can be wiped out by a single careless act of an operator.

Accident prevention and safety are dependent upon the awareness, concern, prudence and proper training of the personnel who operate, transport, maintain and store this equipment. It is your responsibility to use good judgment in the operation of this equipment.

It has been said that **"the best safety device is an informed, careful operator."** We ask you to be that kind of operator.



# DECAL LOCATIONS AND DESCRIPTIONS

Locate and read all decals prior to operating gate  
**REPLACE IF MISSING OR NOT READABLE**

**TOMMY GATE®**

<p style="text-align: center;"><b>DO'S</b></p> <ul style="list-style-type: none"> <li>* DO CENTER YOUR LOAD ON PLATFORM.</li> <li>* DO CLOSE AND LOCK LIFT IN CLOSED POSITION WHEN NOT IN USE OR UNATTENDED.</li> <li>* DO STAND TO THE SIDE OF LIFTGATE WHILE IT IS IN OPERATION.</li> <li>* DO READ MAINTENANCE AND SERVICE INFORMATION.</li> <li>* DO READ OPERATOR'S INSTRUCTIONS.</li> <li>* DO FREQUENTLY CHECK CABLES CHAINS, AND OTHER COMPONENTS FOR WEAR OR DAMAGE AND REPAIR AS NECESSARY WITH PARTS PROVIDED BY THE ORIGINAL EQUIPMENT MANUFACTURER.</li> <li>* DO CHECK ALL SAFETY DEVICES FOR PROPER OPERATION.</li> </ul>	<p style="text-align: center;"><b>DO NOT'S</b></p> <ul style="list-style-type: none"> <li>* DO NOT RIDE OR PERMIT ANYONE TO RIDE ON LIFT. THE LIFT IS NOT A PERSONNEL OR WHEELCHAIR LIFT.</li> <li>* DO NOT MAKE ANY MODIFICATIONS TO THE LIFT OR ITS SAFETY FEATURES.</li> <li>* DO NOT ALLOW USE OF LIFT BY A PERSON WHO HAS NOT HAD PROPER TRAINING IN ITS OPERATION.</li> <li>* DO NOT TRY TO LIFT OR LOWER MORE THAN THE RATED CAPACITY OF THE LIFT.</li> <li>* DO NOT ADD TO OR REMOVE PARTS OF LIFT AS IT WILL VOID YOUR WARRANTY.</li> <li>* DO NOT MOVE VEHICLE UNLESS GATE IS IN LATCHED POSITION.</li> <li>* DO NOT SHOW CHILDREN OR UNAUTHORIZED PERSONNEL HOW TO OPERATE LIFT.</li> <li>* DO NOT LEAVE PLATFORM OPEN, OR UNLATCHED WHEN LIFT IS NOT IN USE OR UNATTENDED. NEVER LEAVE PLATFORM DOWN TO BE USED AS A STEP.</li> </ul>
--	---

ALL REPAIRS OR REINSTALLATIONS OF TOMMY GATE LIFTS SHOULD BE PERFORMED BY AN AUTHORIZED DISTRIBUTOR THAT IS FAMILIAR WITH ITS OPERATION AND SAFETY FEATURES. ALL REPLACEMENT PARTS MUST BE OF ORIGINAL QUALITY. AND ALL SAFETY AND OPERATIONAL DECALS MUST BE ATTACHED AND LEGIBLE

9561

Decal No. 1

Place in cab in a highly visible area.

**WARNING**

--	--	--

Platform opening and closing forces/weights will vary if your vehicle is on an incline.

Stand clear of all moving parts when opening, raising or lowering platform.

Never leave the platform down to be used as a step.

Do not add any extension to original platform.

10626

Decal No. 2

Located near the bottom of folded platform.

**WARNING**

Read operator's manual before operating equipment.

Do not modify lift or its safety features.

Use only Tommy Gate service parts installed by an authorized distributor.

If additional assistance is needed, call Tommy Gate at 712-847-8000.

Do not exceed the rated lift capacity-

9524

Decal No. 3

Located on the side of the control and on the vertical lift arm.

**DANGER**

--	--	--

Keep away from moving parts

9555

Decal No. 4

Located on sides of the upper arms, uprights, and retention ramp latch.

Rated Lift Capacity

1100 lb or 500 kg

15197

Decal No. 5

Located on the side of the control and on the vertical lift arm.



# DECAL LOCATIONS AND DESCRIPTIONS

<p><b>WARNING</b></p> <p>Do not ride on platform. This lift is not designated as a wheelchair or personnel lift.</p>	<p><b>WARNING</b></p> <p>Center load on platform side to side and front to back</p>	<p><b>WARNING</b></p> <p>Never allow children or any untrained person to operate the lift. Do not show children or others how to operate the lift. When the lift is not in use or unattended, the platform should be closed and latched with control secured.</p>

Decal No. 6

Located on the outside of the lidends.

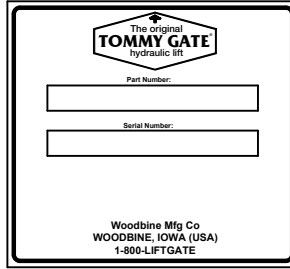

Decal No. 7

Located on upright and inside pump box.



Decal No. 8

Located above the torsion spring plate and bottom of platform.

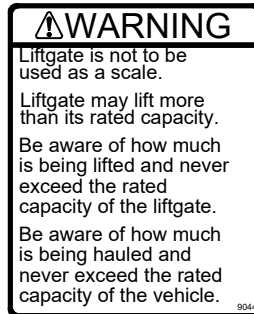

Decal No. 9

Located on the vertical lift arm.

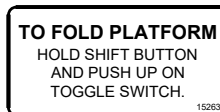

Decal No. 10

Located on the side of the control.



# DECAL LOCATIONS AND DESCRIPTIONS



Decal No. 11  
Located on box cover of pump.

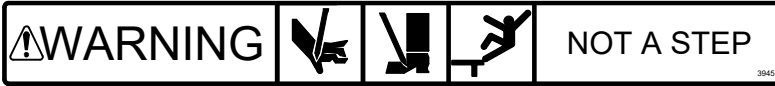

Decal No. 12  
Located on the top of the upper arms.



Decal No. 13  
Located on the inside of both lidends.

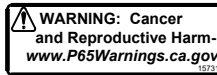

Decal No. 14  
Located on the side of the control.

## DECAL REPLACEMENT

**NOTE: When ordering Decals, please have Decal Numbers available.**

To replace decal, clear area of grease and dirt with nonflammable solvent and soap and water. Allow to dry. To apply decal, peel off 1/2 of back. Hold decal squarely and apply to cleaned surface. Peel off remaining back and smooth in place. Gently rub decal with a damp rag or sponge to smooth out bubbles. (The decal has a pressure sensitive adhesive on the back.)

If the liftgate is going to be painted, you need to mask the decals before painting. Remove the mask after painting so the decals can be read clearly.



## V2 TERMS AND METHOD OF OPERATION

Your Tommy Gate is connected to your vehicle battery. The vehicle battery powers a motor, coupled to a hydraulic pump. This motor and pump combination is called a power unit. Flow from the pump will extend a pair of cylinders to lift the platform. The platform is unfolded and lowered by gravity after electric "release" valves are activated and opened at the power unit and cylinders.

**!Warning:** Liftgate is not to be used as a scale. Liftgate may lift more than its rated capacity. Be aware of how much is being lifted and never exceed the rated capacity of the liftgate. Be aware of how much is being hauled and never exceed the rated capacity of the vehicle.

Tommy Gate's control incorporates a "Low Voltage" warning feature. A "Low Voltage" condition exists when the "Power On" button is armed and 7 Volts or less is present at the power unit. This "Low Voltage" feature is designed to warn the operator that there is a low voltage condition and that it should be corrected as soon as possible. The amber "Power On" LED will blink to warn the operator of this condition. When this light is blinking, it will not prevent the control from functioning to raise or lower the gate. In a "Low Voltage" situation, whether the gate actually raises or lowers depends on how low the voltage is.

**Caution:** Continuing to operate the the liftgate in the "Low Voltage" condition may result in failure of electrical components in the power unit.

The low voltage condition may be caused by a weak battery, loose or corroded connections, improper ground, or bad electrical cables. This condition may be corrected by just starting the vehicle or replacing the battery.

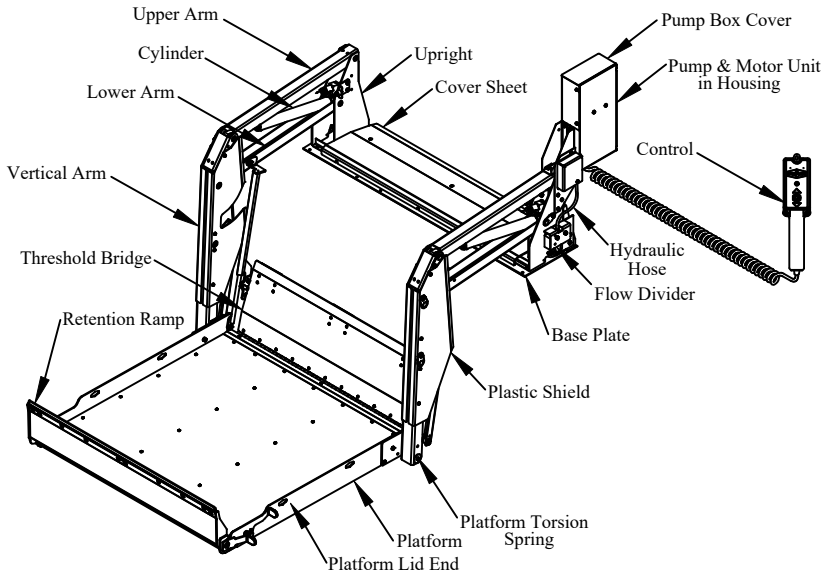

Figure 1: Parts identification.



## OPERATOR'S INSTRUCTIONS

**Step 1.** Never show children or unauthorized personnel how to operate the gate.

**Step 2.** Open the rear doors of the vehicle.

**Step 3.** Be sure to stand clear of the platform and all moving parts when using the lift.

**Step 4.** Remove the control from its storage location.

**Step 5.** To turn the control power on, press the "POWER ON" hidden switch, marked with black rings or circles (located between the Tommy Gate logo and the toggle switch). You should see the amber LED "POWER ON" light when the control is armed. To disarm the control press the "POWER ON" hidden switch again.

To activate the control, press the "LIFTGATE ACTIVATED" hidden switch twice within one second (located under the Tommy Gate logo). You should see the red "LIFTGATE ACTIVATED" light when the control is activated.

To lower the platform, push the toggle switch down. To raise the platform, push the toggle switch up. When you remove pressure from the toggle switch, the operation will stop.

After you have activated the control by pressing the "LIFTGATE ACTIVATED" hidden switch twice within one second (located under the Tommy Gate logo), you have approximately 90 seconds to use the gate. If the gate is not used for approximately 90 seconds, the "LIFTGATE ACTIVATED" timer deactivates the control. If the gate is used during the 90 seconds, the "LIFTGATE ACTIVATED" timer automatically resets for an additional 90 seconds. To reactivate the timer, press the "LIFTGATE ACTIVATED" hidden button twice within one second.

**Step 6.** To lower the platform, stand clear to the side. When you push the toggle switch down on the control, the platform will pivot out of the van. The "shift" button is not used for unfolding the platform. Continue to push the toggle switch down to lower the platform to the ground.



# OPERATOR'S INSTRUCTIONS

- Step 7.** To lower the retention ramp, push down on the latch handle with your hand or foot (Figure 3).
- Step 8.** Position the retention ramp in the vertical position using your hand or foot (Figure 4).
- Step 9.** When raising the load to the vehicle bed level, stand clear of movement of the load, the platform and other moving parts.
- Step 10.** To store the lift, store the retention ramp and raise the platform until the limit switch stops vertical travel. Press and hold the "shift" button on the side of the control. Push the toggle switch up to use the lift hydraulic system to pivot the platform into the stored position. Hang the control on the provided storage bracket.
- Step 11. Never leave the truck unattended with the platform on the ground, partially raised, or open.** To prevent children or unauthorized personnel from operating the lift, be sure the gate is in the stored position. The vehicle doors should be closed and locked before leaving the truck unattended.
- Step 12.** The Tommy Gate is designed for material handling only and is not to be used as a personnel or wheelchair lift. Do not ride on the platform and always stand clear of the platform when opening, raising, lowering, or closing.

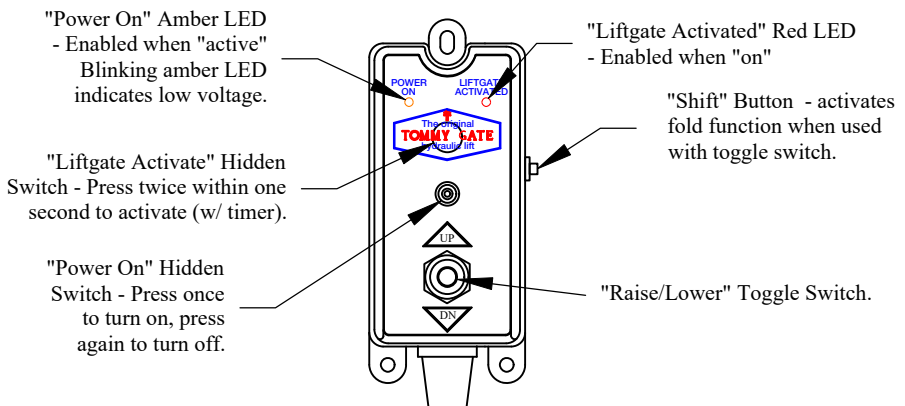

Figure 2: Control.

# RETENTION RAMP OPERATOR'S INSTRUCTIONS

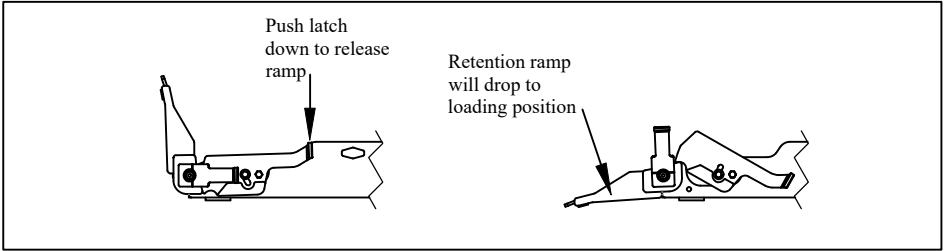

Figure 3: Loading position.

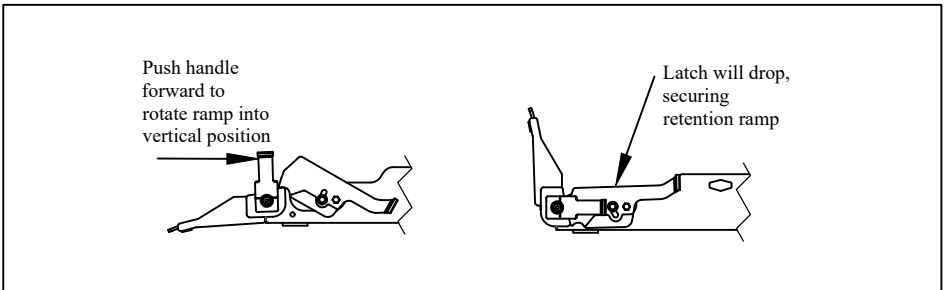

Figure 4: Vertical position.



# ELECTRICAL WIRING DIAGRAM

## Pendant Control

!!! PLEASE READ AND FOLLOW ALL DIRECTIONS BEFORE PROCEEDING !!!



**NOTE !!!** IF GATES ARE NOT WIRED IN ACCORDANCE WITH THIS DIAGRAM YOUR WARRANTY WILL BE VOID.

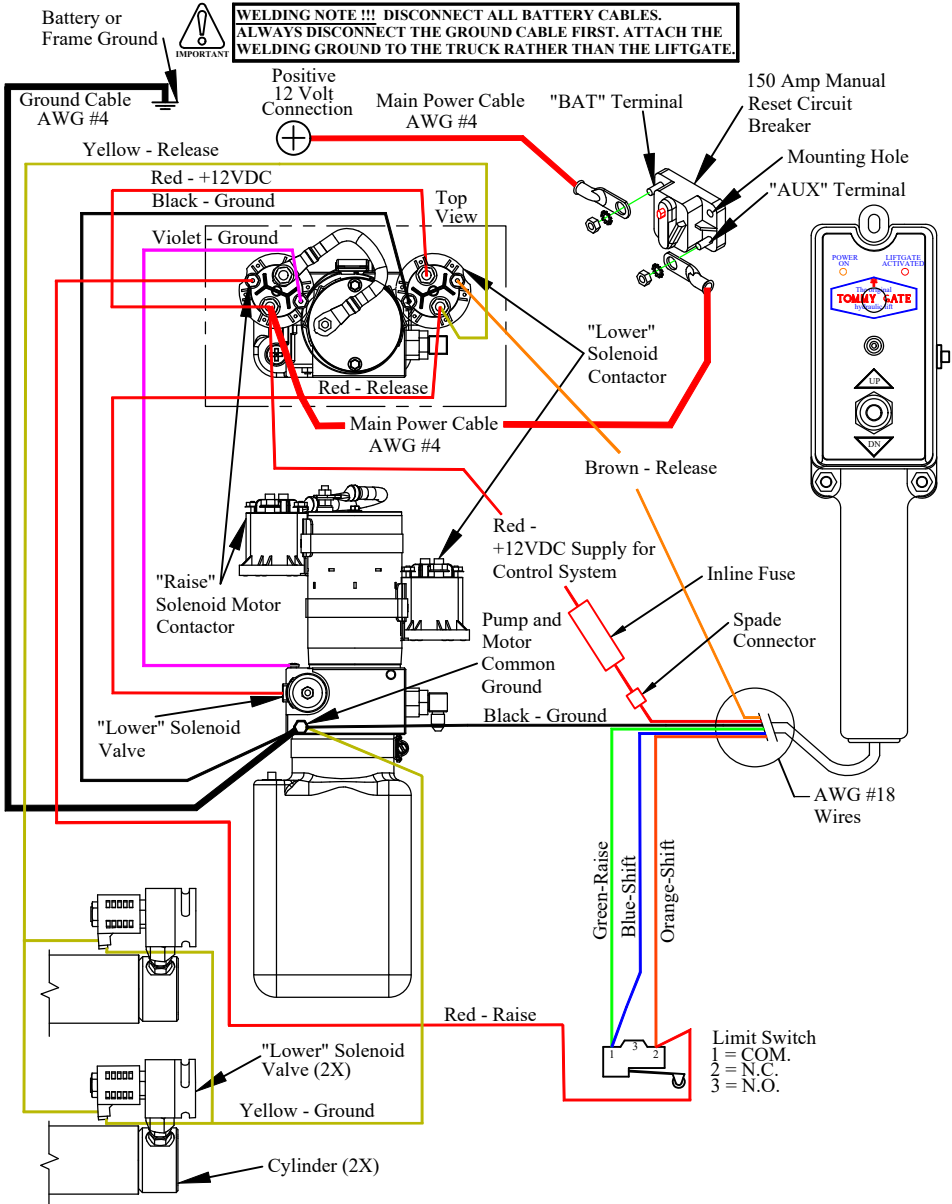
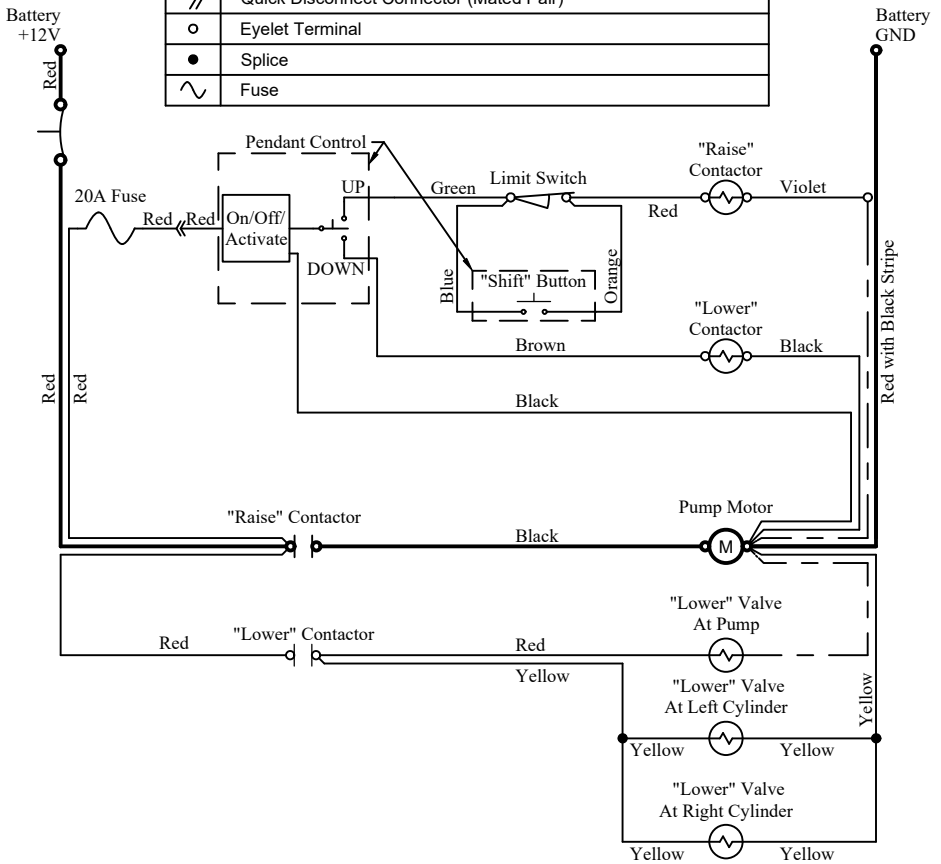

Figure 5: Wiring diagram.



# Ladder Logic/Wiring Diagram

Legend	
	Circuit Breaker
	Push Button
	Toggle Switch
	Limit Switch
	Contactor - Normally Open Contacts
	Motor
	Solenoid/Contactor - Coil
	Battery Cable
	Wire
	Grounded through pump body.
	Quick Disconnect Connector (Mated Pair)
	Eyelet Terminal
	Splice
	Fuse





## MAINTENANCE AND SERVICE INFORMATION

All installations, reinstallations, and repairs of Tommy Gates should be performed by a qualified, authorized distributor that is familiar with its operation and safety features. All replacement parts must be of original quality, and all safety and operational decals must be attached. No modifications are allowed to a Tommy Gate product unless authorized by the Engineering Department at Tommy Gate.

As is with any mechanical product, a preventative maintenance program needs to be followed in order to keep the gate in its best operating condition. Please review this information and if you should have any questions, please call 712-847-8000 . Please have your model number and serial available.

The Tommy Gate needs to be serviced every 120 days or 1500-2000 cycles, whichever comes first.

- (A) Check the oil level in the reservoir. With the liftgate platform at the bottom of its travel, the fluid should be two-thirds full. **BE SURE THE CYLINDERS ARE COMPLETELY COLLAPSED.** Add ISO grade 32 hydraulic oil, Dexron or equivalent, if needed.
- (B) Check for leaks from the cylinder, hoses, and all fittings (replace or repair if found to be leaking).
- (C) Check for cracks in all welds (repair if needed).
- (D) Replace any worn or missing parts before the liftgate is put back into service.
- (E) Check for wear at all pivot points. Check for loose bolts or connectors.
- (F) Check the function of the relief valve, self-closing mechanism, and threshold bridge.
- (G) Check all electrical connections (clean or repair if needed).
- (H) Replace fuses, if required. Check electric cables for worn or damaged insulation.
- (I) Replace or clean safety decals so they are legible.
- (J) Check for proper operation of control.
- (K) Check if limit switch stops the raise function at bed height. Adjust if needed.
- (L) Check if platform touches the ground evenly. Adjust if needed.
- (M) Check for loose bolts or screws. Tighten if needed.



## Adjusting the Platform to Stop at Bed Height

1. **Lower** the platform below bed height.
2. **Raise** the platform as high as it will go with just the pendant toggle.
3. **Check** if the platform loading surface is even with base plate cover (Figure 8).  
If it is even, no adjustment is needed.  
If it is not even, proceed to the next step.
4. **Position** the platform so that it is even with the top of the base plate cover (Figure 8).
5. **Remove** the limit switch cover by removing two (2) 5/16" bolts and nuts (Figure 6).
6. **Loosen** the bolts holding the limit switch (Figure 6).
7. **Move** the limit switch out and then back in until it just clicks.
8. **Tighten** the limit switch bolts with the limit switch in the position previously described.
9. **Install** the limit switch cover with 5/16" bolts and nuts. Be careful not to over tighten the 5/16" bolts (Figure 6).

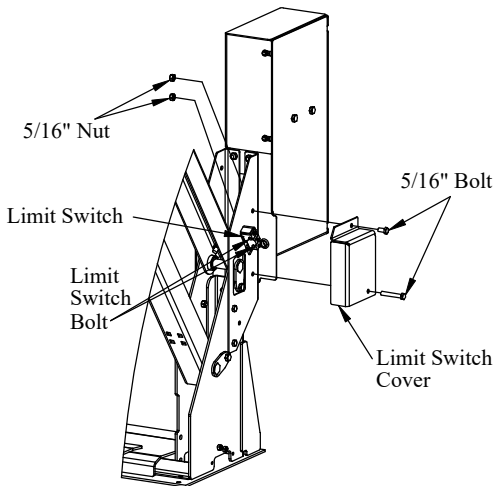

Figure 6: Limit Switch.



## Adjusting the Platform Tilt

1. **Park** the vehicle on level ground.
2. **Lower** the platform to the ground.

The platform taper end should touch the ground.

The platform taper end and hinge end should touch the ground at about the same time.

Note: If the platform tilt is properly adjusted, no adjustment is needed. Otherwise proceed to the next step.

3. **Adjust** the platform set screws until the platform taper end just rests on the ground (Fig. 7).

Turn the set screws in to raise the taper end, and out to lower the taper end.

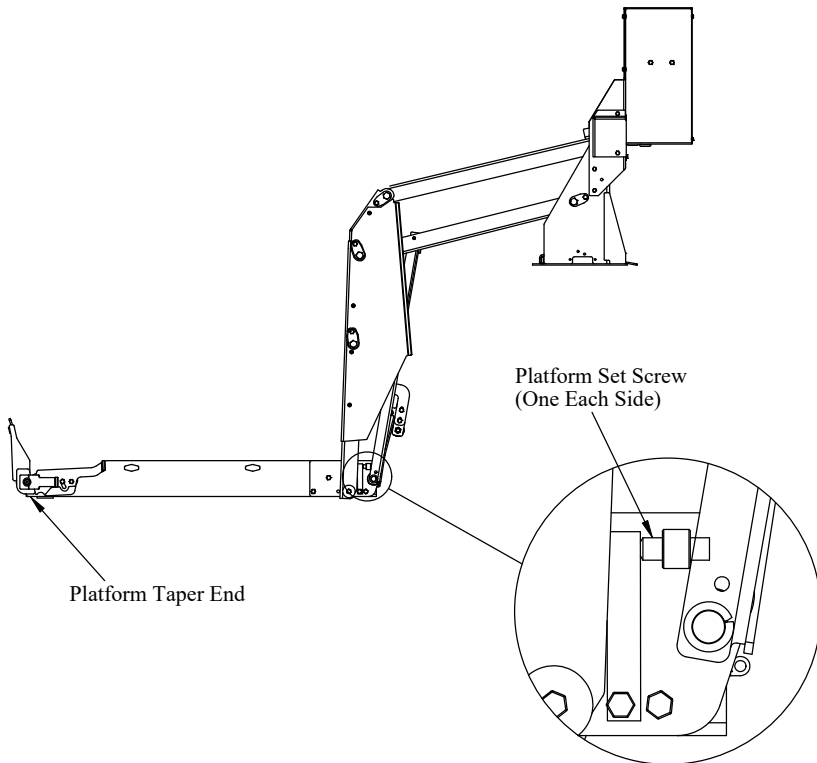

Figure 7: Platform.



## Adjusting the Threshold Bridge

1. **Raise** the platform as high as it will go with just the pendant toggle (Figure 8).
2. **Lower** the platform 1".
3. **Adjust** each bridge close wheel so that it is tight against the bottom of the threshold bridge (Figure 8).
4. **Verify** that:
  - The bridge and bridge close wheels do not hit the bumper, as the lift is lowered.
  - The bridge comes to rest on the base plate cover, without jamming into the base plate cover, when raised to bed height.
5. **Raise and Close** the platform.
6. **Verify** that the rear doors will close without hitting the platform.
7. **Remove** platform stop shims if needed for more door clearance.

Make sure to use the same number of shims in each side (Figure 9).

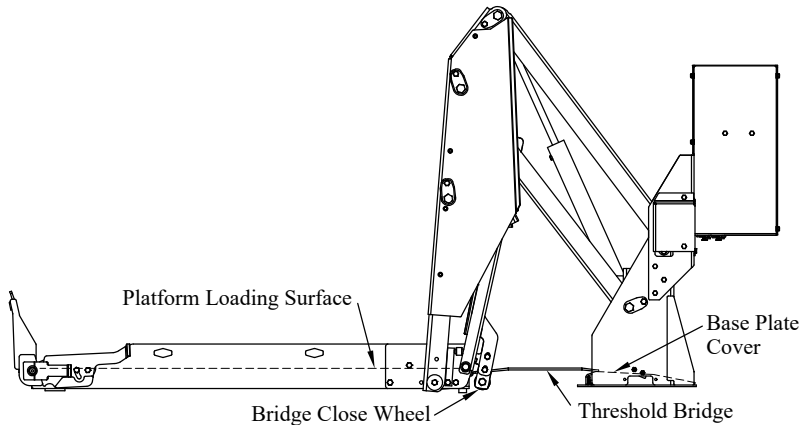

Figure 8: Platform and threshold bridge.

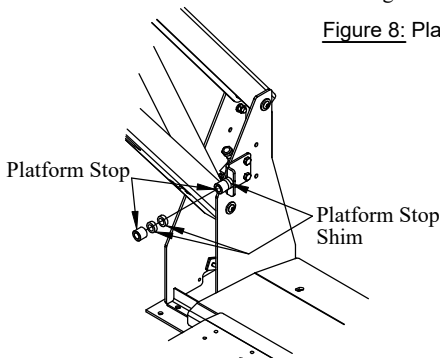

Figure 9: Platform stops.



## TROUBLESHOOTING - V2

<b>PROBLEM</b>	<b>POSSIBLE CAUSE</b>	<b>REMEDIES</b>
1.) Lift will not operate -"POWER ON" amber LED light does not come on.	Control not armed properly.	Turn the power on at the control by pressing the "POWER ON" hidden switch, marked with black rings or circles (located between the Tommy Gate logo and the toggle switch).
	Poor electrical connection.	Check and repair or replace all cables and connections.
	Polarity is reversed.	Switch positive and negative cables.
	Circuit breaker tripped or disengaged.	Check for short, then manually engage circuit breaker.
	Faulty control.	Replace control.
	Blown inline fuse.	Check for short, then replace the inline fuse for the control.
2.) Lift will not operate-"LIFTGATE ACTIVATED" red LED light does not come on.	"POWER ON" amber LED light is blinking.	Low voltage condition. Check and repair or replace all cables and connections.
	Control not activated properly.	Press the "LIFTGATE ACTIVATED" hidden switch twice within one second (located under the Tommy Gate logo). The red "LIFTGATE ACTIVATED" LED light should come on.
	Faulty control.	Replace control.
3.) Blinking amber "POWER ON" LED.	Low voltage condition.	Check and clean or repair all electrical connections. Load test battery, then recharge or replace battery, if required. Reset control.
	Poor grounds or connections.	Repair, replace, clean as necessary.
	Power connected or reconnected since last use.	Normal, press bullseye once to activate solid "POWER ON" amber LED.
4.) Lift will not raise or raises slowly -control working properly.	Poor electrical connection.	Check power and ground cables and all connections.
	Battery charge is low.	Recharge or replace battery.
	Release valve stuck, partially open or dirty.	Raise platform completely and continue to run pump for 5 seconds.
	Release valve needs replacement.	Contact Tommy Gate or distributor.
	"Raise" solenoid not working.	Contact Tommy Gate or distributor.
	Oil level low.	*Check oil and add ISO grade 32 hydraulic oil or equivalent.
	Vent plug not installed or dirty.	Check vent plug on pump tank. A red shipping plug is installed at the factory. It must be replaced by the metal vented plug.
	Overloaded liftgate.	Remove some material or weight.



## TROUBLESHOOTING - V2

<b>PROBLEM</b>	<b>POSSIBLE CAUSE</b>	<b>REMEDIES</b>
5.) Lift settles down slowly with load or no load.	<u>Hoses or fittings leaking.</u>	Tighten or replace.
	Check valve stuck or dirty.	Raise and lower lift several times to flush out valve.
	Check valve damaged.	Contact Tommy Gate or distributor.
	Cylinder seals worn or damaged.	Contact Tommy Gate or distributor.
	"Lower" solenoid sticking partially open	Contact Tommy Gate or distributor.
6.) Pump or motor noisy.	<u>Worn pump, motor or coupling.</u>	Contact Tommy Gate or distributor.
	Oil level low.	Check oil and add Tommy Gate winter grade, ISO grade 32 hydraulic oil, Dexron or equivalent.
7.) Lift lowers very slowly, especially in cold weather.	Cold, thick oil.	Check oil type. Add winter grade Tommy Gate hydraulic oil.
8.) Lift will not lower.	Control not armed and activated-No amber "POWER ON" LED or red LIFTGATE ACTIVATED LED light on.	Press the "POWER ON" hidden switch, marked with black rings or circles (located between the Tommy Gate logo and the toggle switch). The amber "POWER ON" LED light should come on. Now press the hidden "LIFTGATE ACTIVATED" switch twice within one second (located under the Tommy Gate logo). The red "LIFTGATE ACTIVATED" LED light should come on.
	Poor electrical connections.	Check and clean or repair all electrical connections.
	<u>Lift stuck, if control is working</u>	<u>Apply downward load on platform.</u>
	If control is working properly, damaged or non-working "lower" solenoid.	Contact Tommy Gate or distributor.
	<u>Hinge arm or cylinder pins seized.</u>	Lubricate, clean and/or replace pins.
9.) Platform does not fold out of vehicle.	Cold, thick oil.	Check oil type. Add winter grade Tommy Gate hydraulic oil.
	Platform torsion bar broken or out of adjustment.	Contact Tommy Gate or distributor.
10.) Liftgate raises/lowers unevenly	<u>Liftgate platform loaded off center.</u>	Center load on platform side to side.
	Flow divider needs to be reset.	Raise and close empty platform. Continue to run liftgate after platform is closed for 5 seconds.



## STANDARD WARRANTY V2 Series

The Tommy Gate Company provides a limited warranty against faulty materials or workmanship.

### 2-Year Warranty

Tommy Gate pump and motor unit parts are guaranteed for two (2) full years from date of user purchase against faulty materials or workmanship.

### 2-Year Warranty

Tommy Gates are guaranteed for (2) years from the date of user purchase against faulty materials or workmanship.

All affected parts must be returned to the factory prepaid - with full credit issued for those found to be defective. Warranty replacement parts will be shipped from the factory prepaid.

Labor charges to install warranty replacement parts shall be paid in accordance with Tommy Gate's estimated repair time guide and a flat hourly rate established by Tommy Gate.

**DEVIATION FROM THE WARRANTY TIMES LISTED MUST BE AUTHORIZED BY TOMMY GATE COMPANY IN ADVANCE.**

The warranty does not include damage resulting from improper installation procedures. Parts must be installed according to Tommy Gate Company's specifications.

Tommy Gate Company will not pay labor for removing other equipment to gain access to Tommy Gate Equipment. Tommy Gate Company will not pay labor for time on the road to and from a service call.

Tommy Gate Company reserves the right to disallow or reduce claims for parts which have been damaged due to misuse, abuse, accidents, improper shipping; or parts which have been incorrectly or unnecessarily replaced.

The warranty is void if the product has been subject to other than normal use. **THERE ARE NO WARRANTIES, EXPRESS OR IMPLIED, INCLUDING THE WARRANTY OF MERCHANTABILITY OR A WARRANTY OF FITNESS FOR A PARTICULAR PURPOSE EXTENDING BEYOND THAT SET FORTH ABOVE.**

**NOTE: SEE FOLLOWING PAGE FOR THE WARRANTY CLAIMS HANDLING PROCEDURE.**



## WARRANTY CLAIMS HANDLING PROCEDURE

The following procedures are required when an authorized distributor submits a warranty claim for a defective Tommy Gate part:

1. Before any expense is incurred, but after the problem has been diagnosed, the authorized distributor should contact Tommy Gate Company's Warranty Department to discuss the problem and its correction.
2. If it is determined that the condition is potentially covered by Tommy Gate Company's warranty, the authorized distributor will receive instructions on how to proceed. A decision will be made to either repair or replace the product or part in question.
3. If the product or parts are to be repaired, the authorized distributor will receive a **WARRANTY REQUEST NUMBER**.
4. If the product or parts are to be replaced, the authorized distributor will be instructed to either hold the parts for inspection by a representative, in which case the authorized distributor will receive a **WARRANTY REQUEST NUMBER**, or the authorized distributor will be asked to return the product for inspection to Tommy Gate Company, in which case the authorized distributor will receive a **RETURN GOODS AUTHORIZATION NUMBER**. Under no circumstances are parts to be returned without a **RETURN GOODS AUTHORIZATION NUMBER**.
5. After the repair or replacement work is completed, the authorized distributor will submit the claim to Tommy Gate Company with the following information.
  - a. Tommy Gate Company **WARRANTY REQUEST** and/or **RETURN GOODS AUTHORIZATION NUMBER**.
  - b. Tommy Gate model number.
  - c. Tommy Gate serial number.
  - d. Tommy Gate part number involved and a description of the apparent problem or defect.
  - e. Authorized distributor performing warranty work.
  - f. Person responsible for warranty work (contact).
  - g. Distributor from whom liftgate was purchased.
  - h. Liftgate owner's name, address, and phone number.
  - i. Action taken, cost involved, complete with work orders and parts expense invoices.
6. If defective parts are to be returned to Tommy Gate Company they:
  - a. Must be packaged for each individual warranty return. No multiple warranty claims in the same box.
  - b. Must be returned "freight prepaid" to Tommy Gate Company's location.
  - c. Must be clearly marked with the **RETURN GOODS AUTHORIZATION NUMBER** on the outside of the package.

Warranty claims must be submitted by the Authorized Distributor on behalf of their customer as part of their customer assistance.

Warranty claim acceptance or rejection is based solely upon defective part inspection and a review of the claim date (outlined in step 5 above) as they apply to the requirements of Tommy Gate Warranty. Claim reimbursement after acceptance is governed by those allowances previously agreed upon between Tommy Gate Company and the Authorized Distributor (as outlined in Steps 1-4 above).

**Any warranty claims submitted without a WARRANTY REQUEST NUMBER or RETURN GOODS AUTHORIZATION NUMBER and the necessary information will be denied.**

# V2 REPAIR PARTS DRAWING

## FOR MODELS 1140

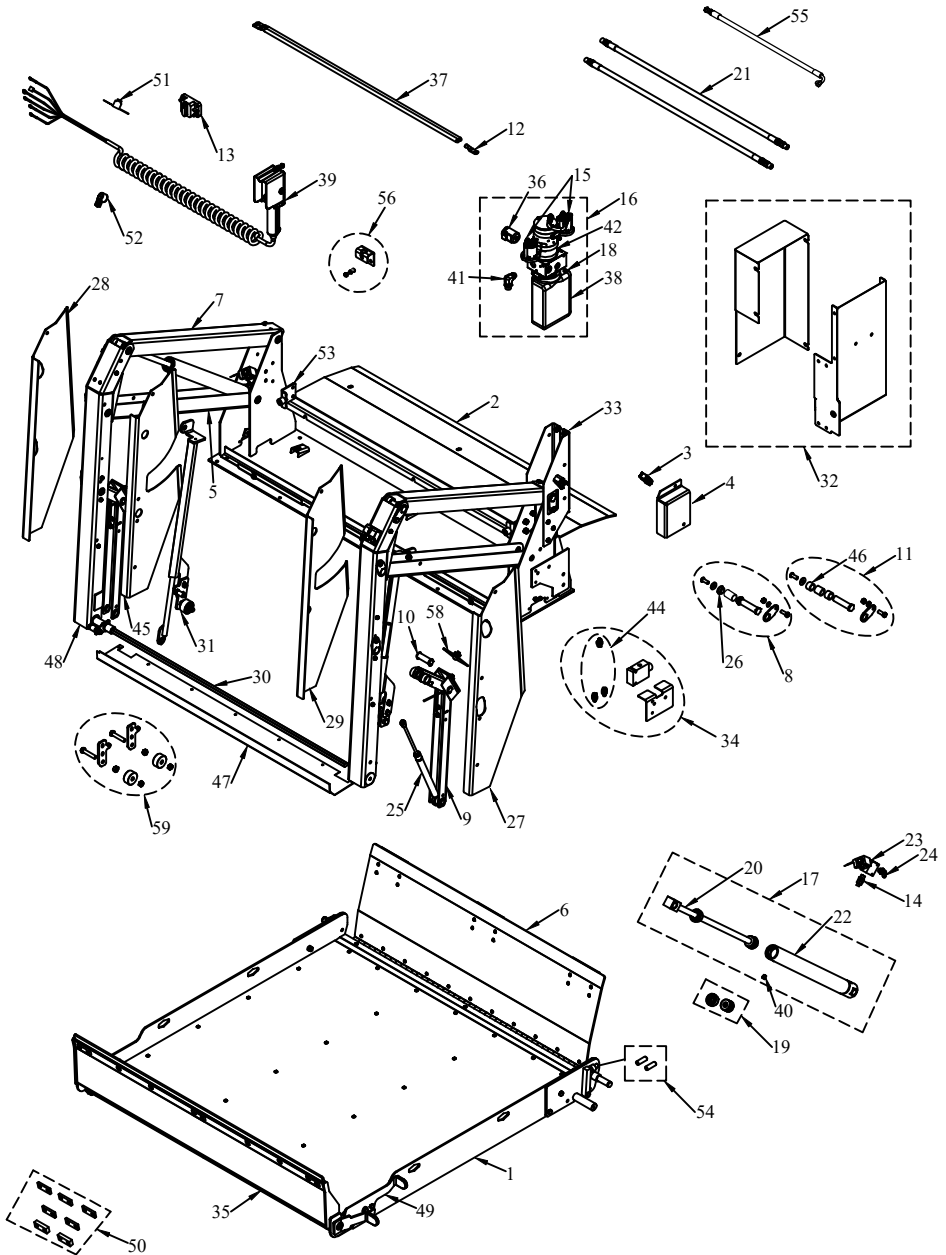

# V2 REPAIR PARTS DRAWING

## FOR MODELS 1145

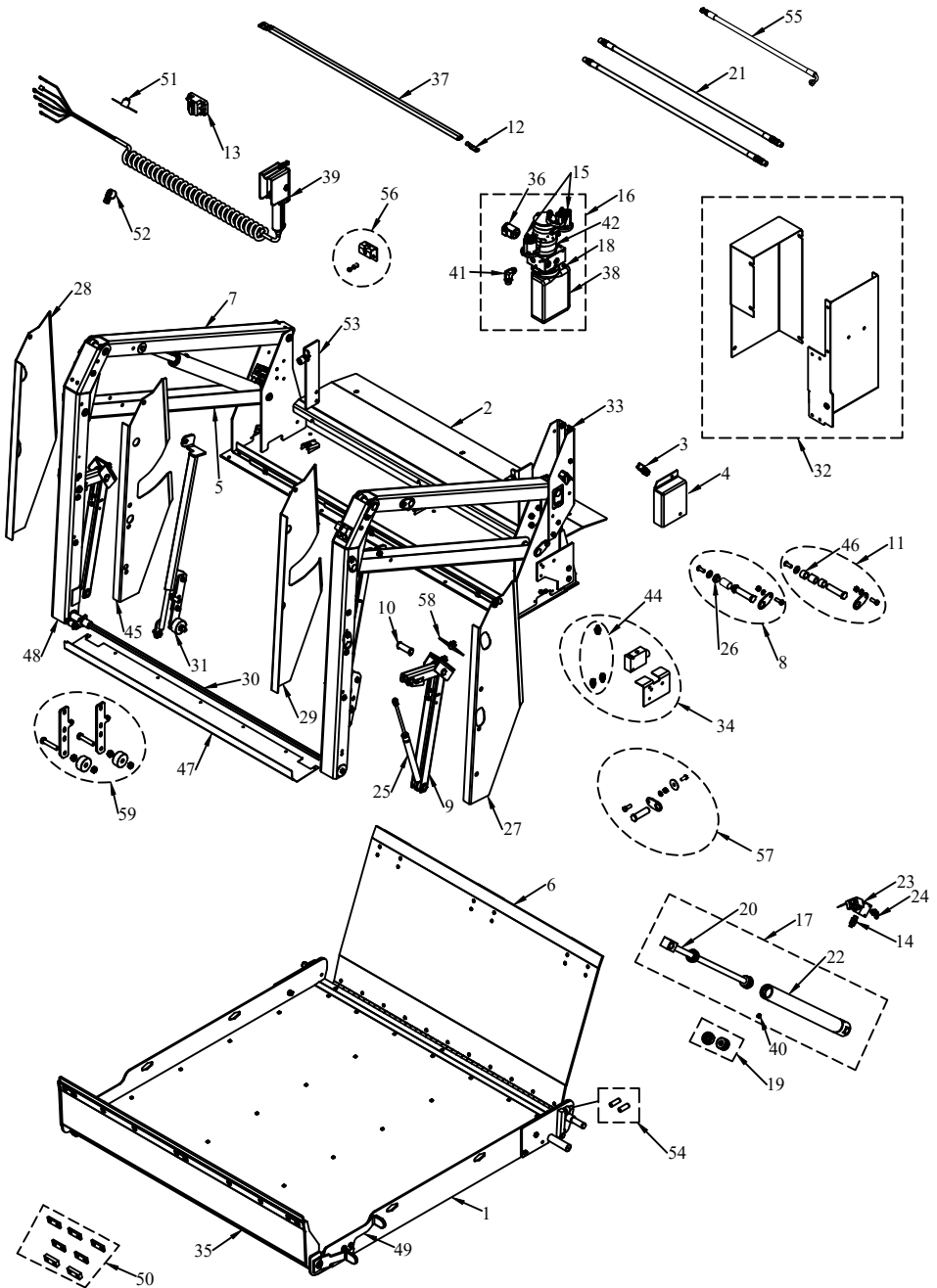



## V2 REPAIR PARTS LIST

ITEM#	DESCRIPTION	ITEM#	DESCRIPTION
1	Platform	30	Torsion Spring
2	Cover Sheet	31	Threshold Bridge Guide (R and L)
3	Limit Switch	32	Pump Box
4	Limit Switch Cover	33	Pump Box Bracket
5	Lower Arm	34	Flow Divider
6	Threshold Bridge	35	Retention Ramp
7	Upper Arm	36	"Lower" Solenoid
8	Lower Arm Pin	37	4 Ga. 2 Wire Electric Cable
9	Fold Link Assembly	38	Tank
10	Fold Link Pin	39	Timed Control
11	Upper Arm Pin	40	Vent Plug-Cylinder
12	Copper Lug	41	Pump Elbow-90deg
13	Manual Reset Circuit Breaker	42	Motor Only
14	Cylinder Straight Fitting	44	Flow Divider Fittings
15	Solenoid	45	Driver Side Inside Plastic Shield
16	Pump & Motor	46	Upper Arm Bushing
17	Cylinder	47	Torsion Spring Cover
18	Vent Plug	48	Vertical Arm (R and L)
19	Cylinder Seal Repair Kit	49	Platform Latch
20	Cylinder Shaft Kit	50	Platform Bumper Kit
21	Hydraulic Hose - Cylinder	51	Control Fuse
22	Cylinder Barrel Kit	52	Control Cord Clamp
23	Cylinder Lock	53	Platform Stop
24	Cylinder Lock Elbow-45 deg	54	Platform Tilt Set Screw Kit
25	Damper	55	Hydraulic Hose - Flow Divider
26	Split Bushing	56	Pendant Control Bracket
27	Passenger Side Outside Plastic Shield	57	Upper Arm Cylinder Pin Kit
28	Driver Side Outside Plastic Shield	58	Tilt Link Wear Pad Kit
29	Passenger Side Inside Plastic Shield	59	Bridge Close Adjuster



**THIS PAGE**  
**INTENTIONALLY LEFT**  
**BLANK**



**THIS PAGE**  
**INTENTIONALLY LEFT**  
**BLANK**



**THIS PAGE**  
**INTENTIONALLY LEFT**  
**BLANK**





**Manufacturing Plant:**  
83 Bus Brown Drive  
Woodbine, Iowa 51579  
FAX (712) 647-2417

**Corporate Offices:**  
33717 N. Scottsdale Rd. Ste 120  
Scottsdale, AZ 85266  
FAX (602) 955-3902

**(712) 847-8000**  
**[www.tommygate.com](http://www.tommygate.com)**