

ITEM NO.	QTY.	PART NO.	DESCRIPTION
1	1	014154	81-42 22+11+4 TP PLATFORM COMPLETE
2	1	007872	.375"x79.063" TORSION SPRING(EA80)
3	2	004727	3/8"U-BOLT(SHORT)x16x7/8x1-1/2
4	4	000605	3/8-16 USS CROWN LOCK NUT
5	4	000550	3/8-16 GR5 HEX NUT
6	2	004714	PLATFORM LATCH PIN (G2)
7	2	000587	1/2-13x1" HHCS GR5
8	1	000551	1/2-13 GR5 HEX NUT (ZINC)
9	1	007431	HINGE TUBE SPRING HOLDER-PASS64SB/72
10	1	007778	HINGE TUBE SPRING HOLDER-EA DRIVER
11	2	000573	1/2" SPRING LOCKWASHER
12	2	013304	PLATFORM HINGE-BLACK NYLON 6/6
13	2	000624	5/16" USS THRU HARD WASHER
14	2	000553	3/8-16 LARGE FLANGE LOCK NUT
15	2	009540*	WARNING DECAL - SPRING TENSION
16	1	009513	DECAL SHEET-CABLE/G2 W/WEIGHT CAP.(NOT SHOWN)
17	1	095064	PLATFORM / TORSION SPRING INSTR. (CABLE/G2)

*DO NOT INCLUDE IN ACCOUNTING BOM

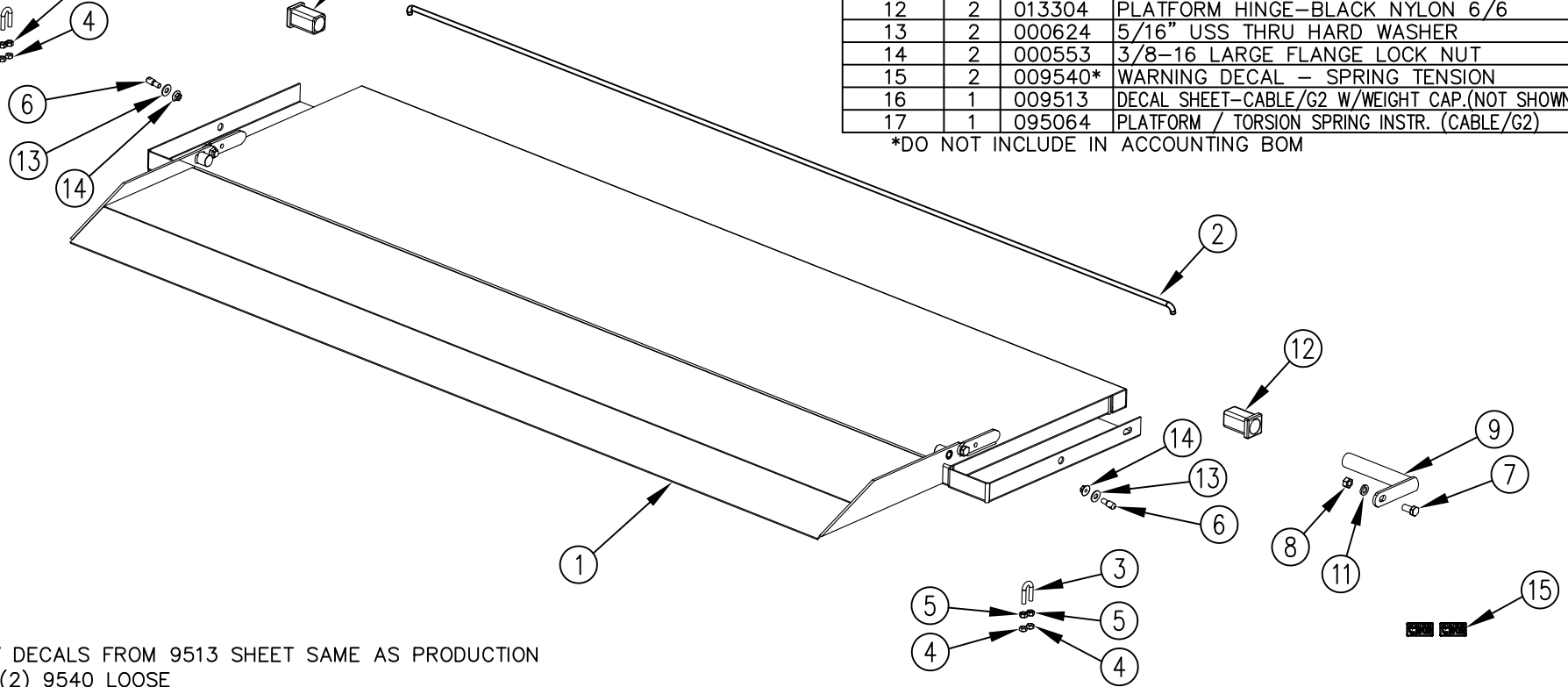

NOTES: APPLY DECALS FROM 9513 SHEET SAME AS PRODUCTION
SEND (2) 9540 LOOSE

						THIRD ANGLE PROJECTION 	DRAWN BY AAS	NOTES:	WOODBINE MFG. CO. BUS BROWN DRIVE WOODBINE, IOWA 51579
						UNLESS OTHERWISE SPECIFIED	DRAWN/DATE 9/6/24		
						DIMENSIONS ARE IN INCHES	APPVD/DATE -		
						TOLERANCES: FRACTIONAL ±1/16 ANGULAR MACH ±1° BEND ±1° TWO PLACE DECIMAL ±0.030 THREE PLACE DECIMAL ±0.010	DO NOT SCALE DRAWING		
A	9/6/24	RELEASED TO PRODUCTION	AAS	3051				TITLE G2 81 27+11+4 TP REPLACEMENT PLATFORM	
REV.	DATE	CHANGE RECORD	BY	APPVD	ECN	THE INFORMATION HERE IS CONFIDENTIAL AND MUST NOT BE USED IN ANY WAY DETRIMENTAL TO THE INTEREST OF WOODBINE MFG.	SCALE 1:14	WEIGHT -	PART NO. 18328