

ITEM NO.	QTY.	PART NO.	DESCRIPTION
1	1	000517	3/8-16x2-1/2" HHCS GR5
2	1	003823	2" COMPRESSION SPRING(.53"OD)
3	1	014033	LATCH KNOB WITH STUD (RR)
4	1	014602	PLATED RR LATCH BLOCK
5	1	095215	BF RETENTION LATCH REPLACEMENT INSTRUCTIONS

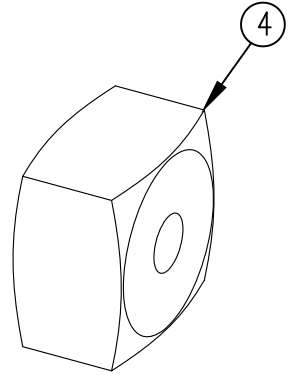
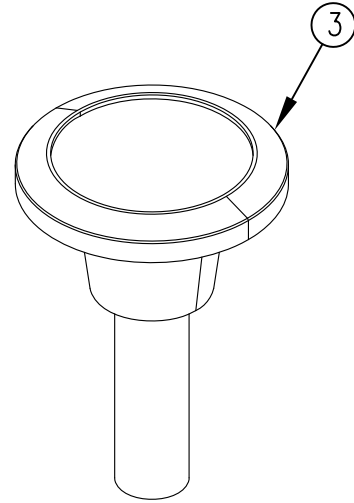
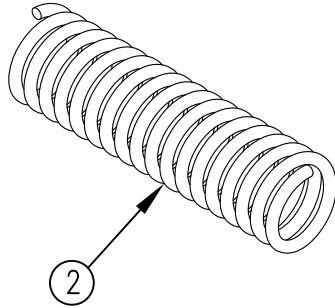
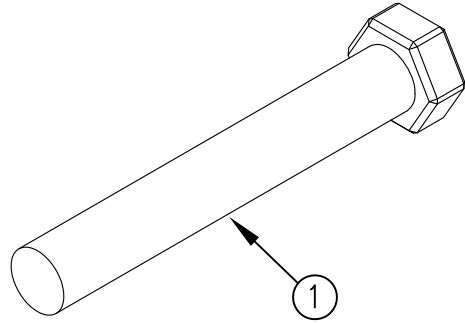

REV.	DATE	CHANGE RECORD	BY	APPVD	ECN	DRAFT 2"	ANGULAR ±1°	SYMBOLY PER ANSI Y14.5	NOTES:	WOODBINE MFG. CO. BUS BROWN DRIVE WOODBINE, IOWA 51579					
								THIRD ANGLE PROJECTION 							
						DECIMAL	2PLC	3PLC	DRAWN BY. AAS						
						MACHINE SAW,DRILL	.030	.015	DRAWN/DATE 3/10/16						
A	2/9/17	FIXED PART NUMBER REFERENCE 5 WAS 095180	AAS			SHEAR, PUNCH FORM	.060	.030							
A	3/10/16	RELEASED TO PRODUCTION	AAS		1593	TORCH, WELDING ROUGH CAST	.090	.060	TITLE REPLACEMENT RETENTION RAMP LATCH KIT-BF						
										SCALE	FIN. WT.	PART NO. 14668			