

ITEM NO.	QTY.	PART NO.	DESCRIPTION
1	1	011604	30" TP MAIN PLATFORM(TUCKUNDER)
2	2	011527	1.24"DIA.x17.50"PLATFORM PIN(TUCKUNDER)
3	2	011524	.25"x2.50"x3.19"SPRING PLATE(TUCKUNDER)
4	4	000509	3/8-16x1" HHCS GR5
5	8	000605	3/8-16 USS CROWN LOCK NUT
6	2	013019	3/8-16x3-1/2" SOCKET HEAD CAP SCREW
7	2	010046	3/8-16x3-1/2" HHCS GR5
8	2	011656	5/8x1.25" SHOULDER BOLT-ZINC PLATED(1/2-13)
9	2	000588	1/2" CROWN LOCK NUT
10	2	012834	ZINC PLATED PLATFORM SHIM (TUCKUNDER)
11	4	010502	5/16-18x1" HHCS GR5 BOLT
12	4	000606	5/16-18 USS CROWN LOCK NUT
13	1	011575	SPRING COVER PLATE (TUCKUNDER)
14	4	000620	1/4-20x1/2" PN HD TY FS
15	2	009540	CAUTION DECAL - SPRING TENSION
16	1	009506	DECAL SHEET-RAILGATE
17	1	095169	REPAIR TKT TP PLATFORM INSTRUCTIONS

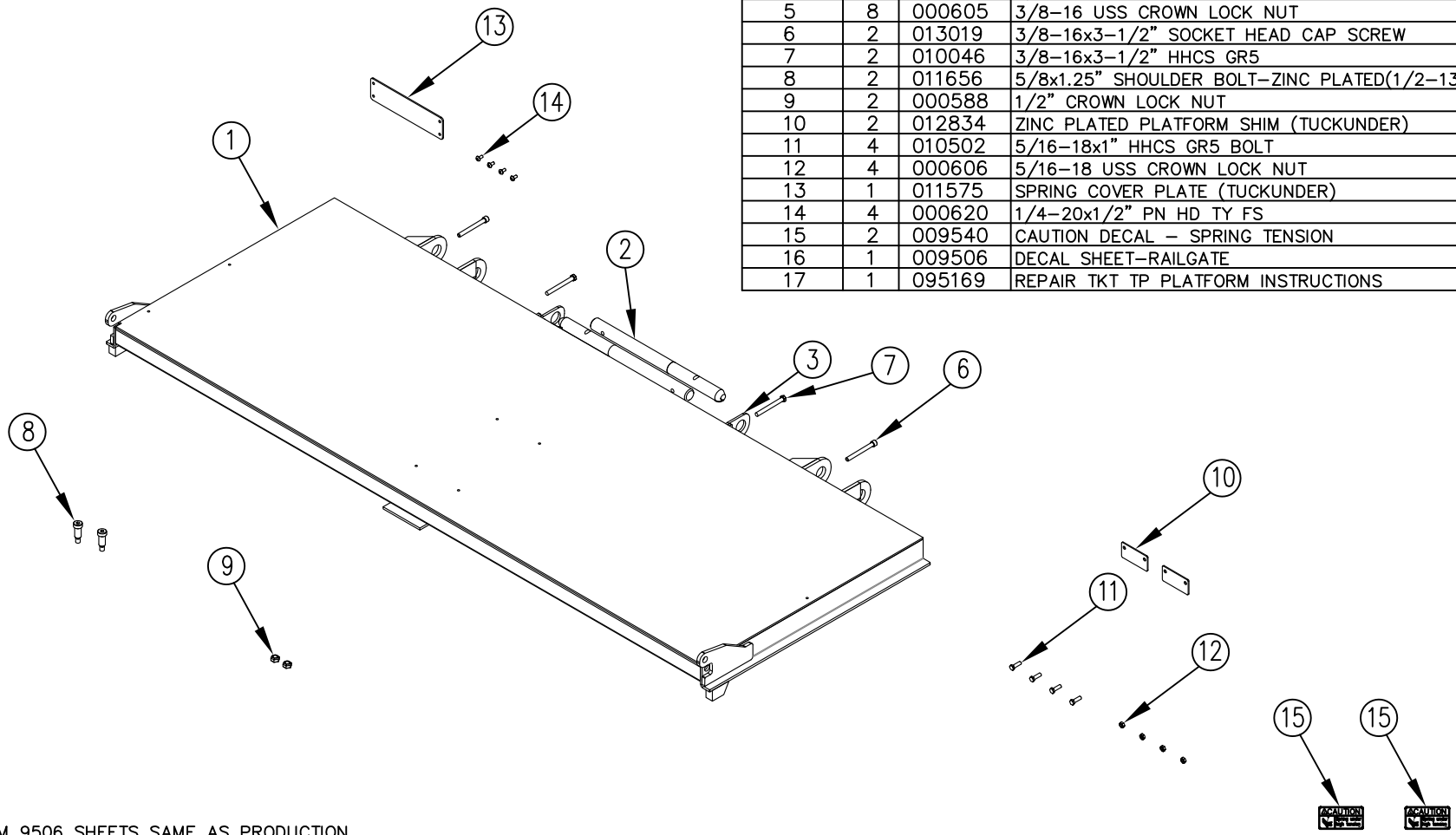

NOTE: APPLY DECALS FROM 9506 SHEETS SAME AS PRODUCTION

					THIRD ANGLE PROJECTION 	DRAWN BY GDB		NOTES:		WOODBINE MFG. CO. BUS BROWN DRIVE WOODBINE, IOWA 51579 	
					UNLESS OTHERWISE SPECIFIED	DRAWN/DATE 3/20/15					
B	12/21/18	ADDED 011575 AND (4) 000620	GDB	2150	DIMENSIONS ARE IN INCHES	APPVD/DATE -		TITLE REPL. 30" TP MAIN PLATFORM (TUCKUNDER)		SCALE 1:8	
A.1	3/26/15	BILL CORRECTIONS TO MATCH PRODUCTION	GDB		TOLERANCES: FRACTIONAL ±1/16 ANGULAR MACH ±1° BEND ±1°	DO NOT SCALE DRAWING					
A	3/20/15	RELEASED TO PRODUCTION	GDB	1348	TWO PLACE DECIMAL ±0.030 THREE PLACE DECIMAL ±0.010					PART NO. 14340	
REV.	DATE	CHANGE RECORD	BY	APPVD	ECN	THE INFORMATION HERE IS CONFIDENTIAL AND MUST NOT BE USED IN ANY WAY DETRIMENTAL TO THE INTEREST OF WOODBINE MFG.					