

ITEM NO.	QTY.	PART NO.	DESCRIPTION
1	1	1004059	91 SUB ASSEMBLY WELDMENT(NEW STYLE)
2	4	1007543	7/8"x1-1/2" ARM PIN
3	2	1007544	5/16"x11/16" F.H.RIVET
4	2	1003820	KICKER SPRING
5	2	1000606	5/16-18 USS CROWN LOCK NUT
6	2	1010340	DRDP PIN ASSEMBLY
7	2	1000615	5/8" EXTERNAL RETAINING RING-PLATED
8	2	1010337	DRDP CHAIN MACHINED WASHER
9	2	1010467	5/16-18 X 2" FLHD SHCS - ZINC
10	1	1095046	SUB-ASSEMBLY REPLACEMENT - ORIGINAL SERIES

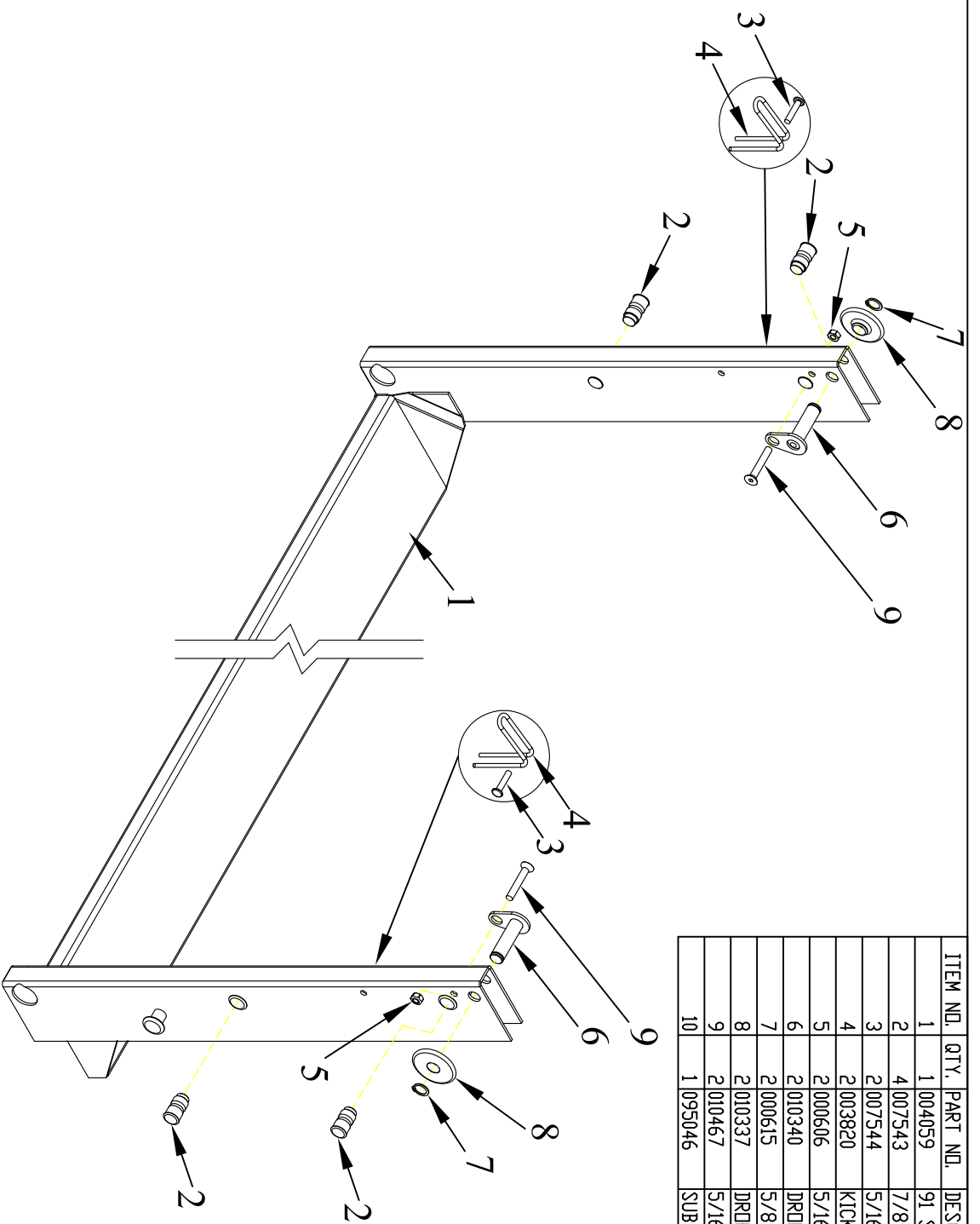

REV.	DATE	BY	APPVD	ECON	DRAFT	ANGULAR	FILENAME:	SCALE	FIN. WT.	PART NO.
B	3/1/10	MTC		270	2-	±1"	WOODBINE MFG. CO. BUS BROWN DRIVE WOODBINE, IOWA 51579	N		4060
C	3/3/11	JCB		415			712-647-2050 TOMMY GATE The original Hydraulic lift			
							NOTES:			
							91 REPLACEMENT SUB ASSEMBLY(NEW STYLE)			
							THE INFORMATION HERE IS CONFIDENTIAL AND MUST NOT BE USED IN ANYWAY DETERIMENTAL TO THE INTEREST OF WOODBINE MFG.			
							DECIMAL 12PLC 3PLC MACHINE .030 .015 SAW,DRILL SHEAR .060 .030 PUNCH FORM TORCH, WELDING ROUGH CAST .090 .060			
							DRAWN BY: DJR DRAWN/DATE: 11/22/04			
							THIRD ANGLE PROJECTION ANSI Y14.5			
							REMOVED PN4769 AND 3818: ADDED PN10340, 615, 10337, 10467, 7544, 3820, 606			
							REPLACED 95042 WITH 95046			
							CHANGE RECORD			