

DETAILED LIFTGATE DIMENSIONS

VAN BODY



								A	B	C	D	E	F	G	H	I	K	L	M
V2-56-1145 FA49	45	1100	45	480	47-1/2	49-3/16	48-1/2	57-1/2	69-1/4	49	9	66-5/16	62-5/8	57	36	17			

IMPORTANT

- There are numerous truck configurations and body styles. Check the clearance of the liftgate with any bumpers or additional equipment on the back of the truck.

NOTES

1. For total gate weight, add gate weight and bracket weight. Total gate weight does not include mounting kit or pallet
2. Dimension gives overall height for installation of FA49 platforms **only**
3. Travel will be dependent on liftgate mounting location. Refer to Clearance chart DPN95373

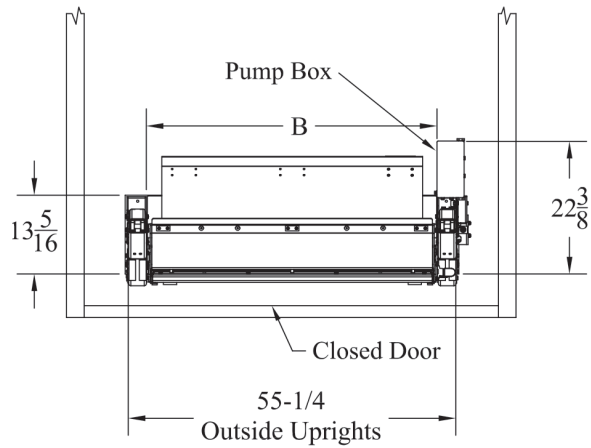
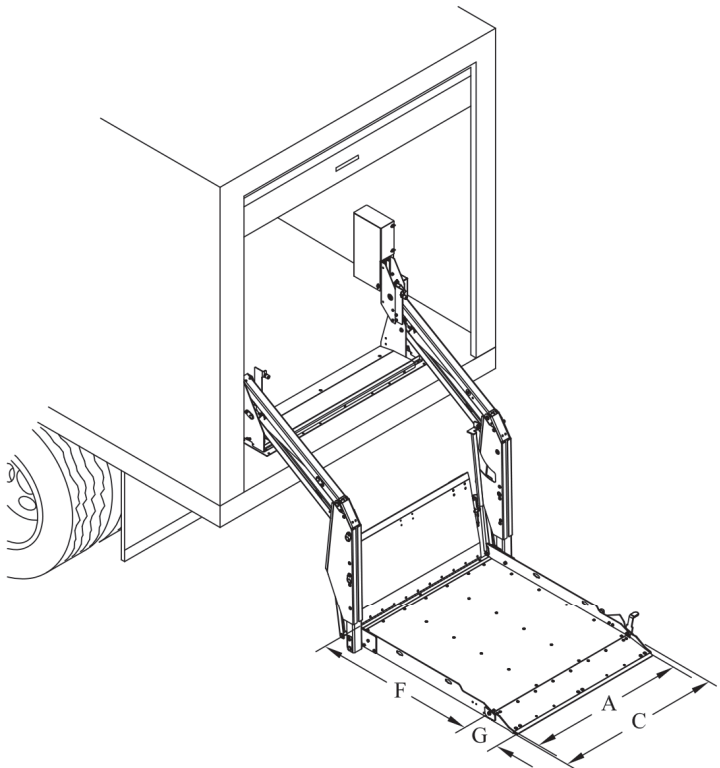

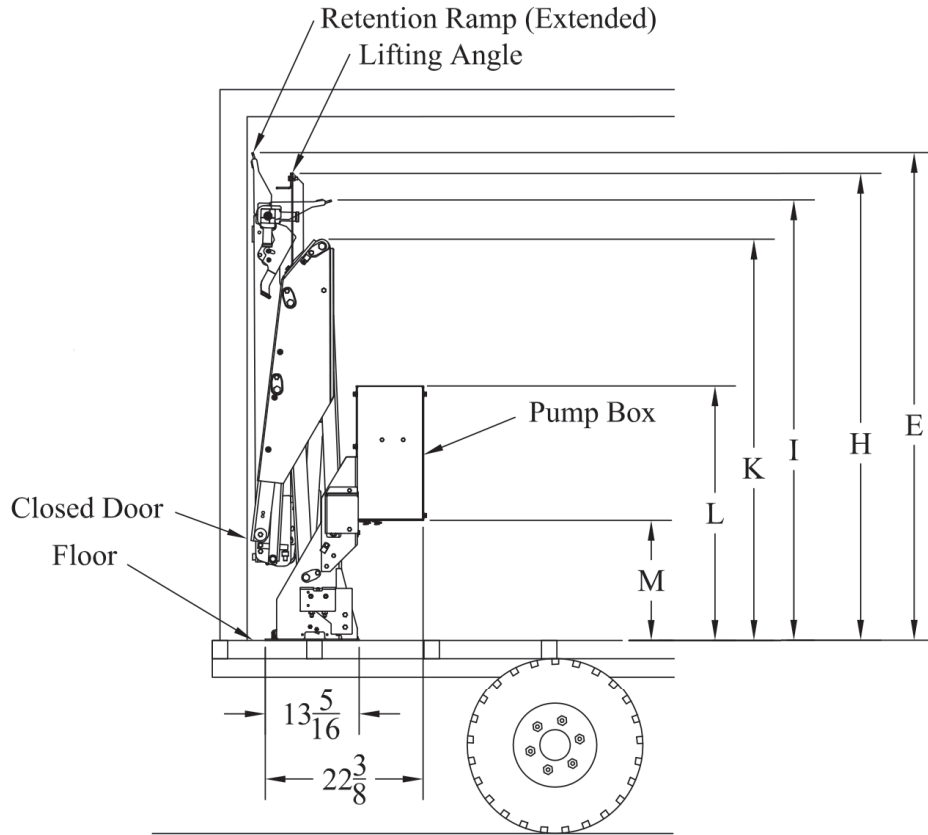

V2 SERIES CLEARANCE (for 45-inch travel)

All dimensions are in inches unless otherwise specified.

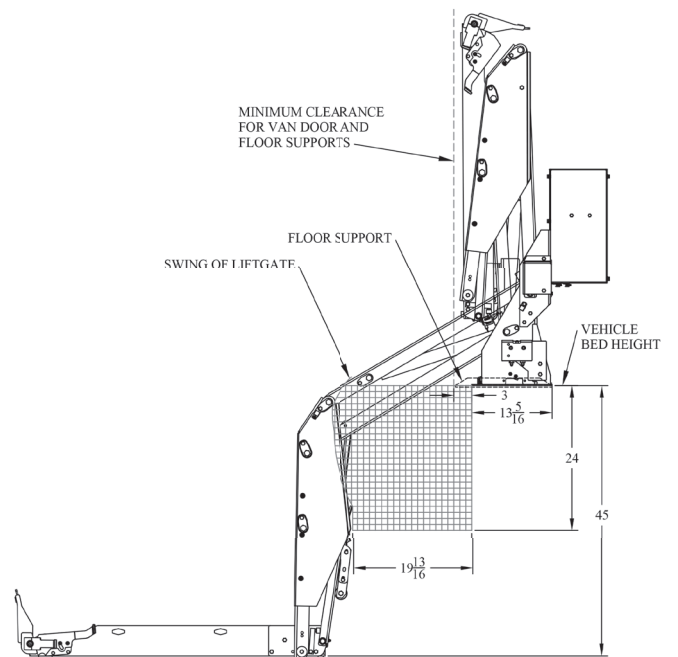
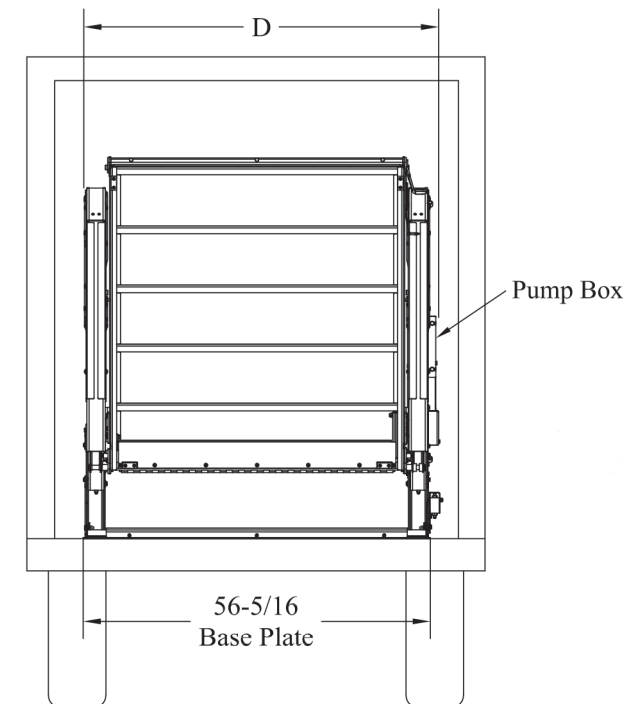

□=1" SQUARE
SCALE=1:12