

ITEM NO.	QTY.	PART NO.	DESCRIPTION
1	1	9808	72-1040 LP W/F11 TP PLATFORM COMPL
2	1	3774	.38"x73.75" TORSION SPRING(72)
3	1	10333	1.25" PUNCHED INNER HINGE TUBE (72)
4	2	4728	3/8"U-BOLT(LONG)x16x7/8x2-1/16
5	4	605	3/8-16 USS CROWN LOCK NUT
6	4	550	3/8-16 GR5 HEX NUT
7	1	7491	SPRING HOLDER
8	1	4726	5/16" U-BOLT
9	1	508	3/8-16x3/4" HHCS GR5
10	1	510	3/8-16x1-1/4" HHCS
11	1	7304	10GA.x1"x2.75" SPRING CLIP
12	2	606	5/16-18 USS CROWN LOCK NUT
13	2	4720	1/4"x2" COTTER PIN
14	2	*9540	CAUTION DECAL - SPRING TENSION
15	1	9513	DECAL SHEET-CABLE/G2 W/WEIGHT CAP.
16	1	95080	(C)(G)PLAT/TORSION SPRNG(W/HINGE TUBE)

* DO NOT USE IN ACCOUNTING BOM

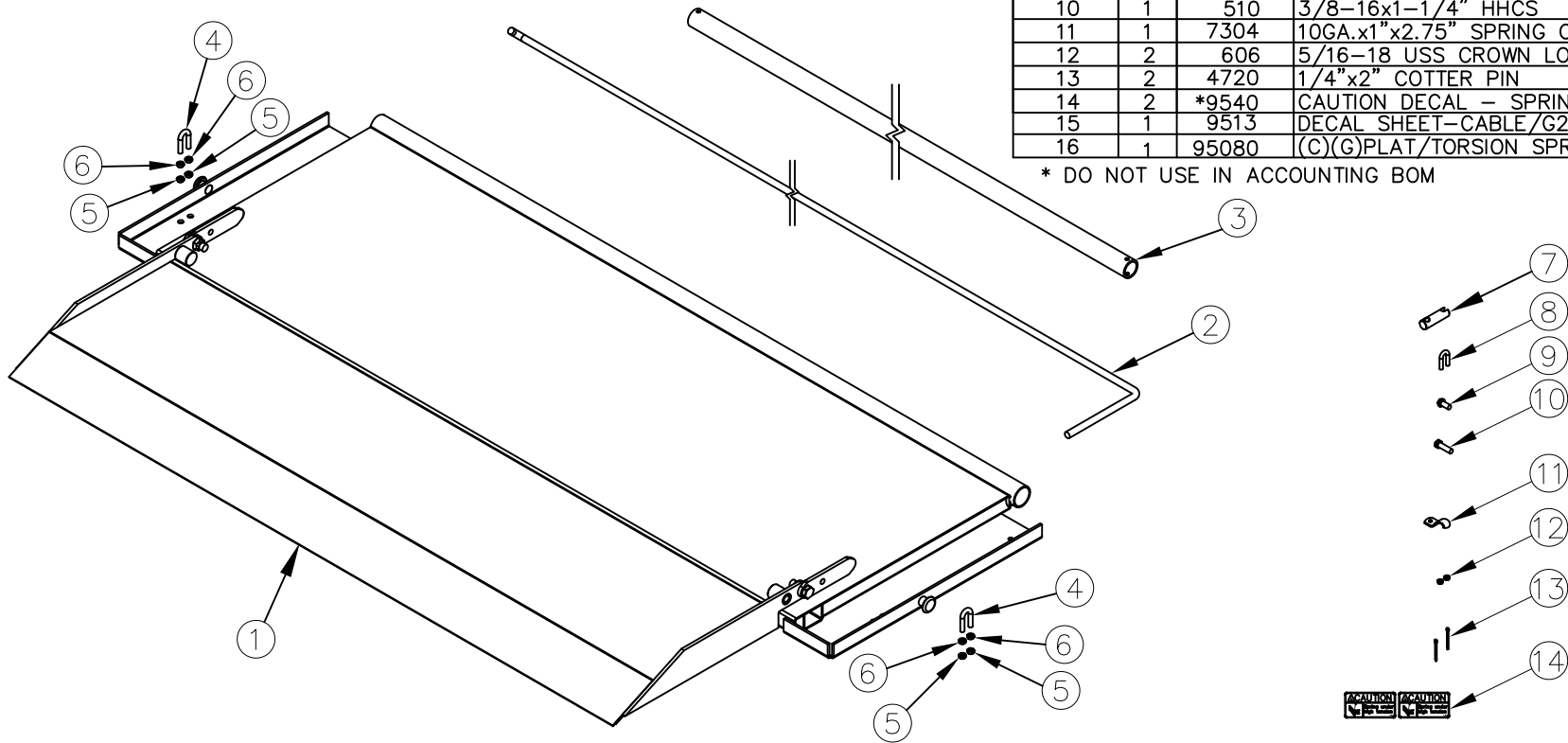

NOTES: APPLY DECALS FROM 9513 SHEET SAME AS PRODUCTION

SEND (2) 9540 LOOSE

REV.	DATE	CHANGE RECORD	BY	APPVD	ECN	THIRD ANGLE PROJECTION			FILENAME:		NOTES:	WOODBINE MFG. CO. BUS BROWN DRIVE WOODBINE, IOWA 51579	
						DECIMAL	2PLC	3PLC	SYMBOLY PER ANSI Y14.5				
B	8/26/22	ADDED 95080, 9513	AAS		2780	MACHINE SAW, DRILL	.030	.015	DRAWN BY. JCB				
A	9/16/13	CREATED DRAWING	JCB		964	SHEAR, PUNCH FORM	.060	.030	DRAWN/DATE 9/16/13				THE INFORMATION HERE IS CONFIDENTIAL AND MUST NOT BE USED IN ANYWAY DETRIMENTAL TO THE INTEREST OF WOODBINE MFG.
						TORCH, WELDING ROUGH CAST	.090	.060	APPVD/DATE	TITLE			
						DRAFT 2'		ANGULAR ±1°	SALES CATEGORY	PRODUCT LINE	SCALE N	FIN. WT.	PART NO. 1227