

ITEM NO.	QTY.	PART NO.	DESCRIPTION
1	1	014151	G2 SUB ASSEMBLY(81-42)
2	1	000587	1/2-13x1" HHCS GR5
3	1	000573	1/2" SPRING LOCK WASHER
4	1	000588	1/2-13 CROWN LOCK NUT
5	1	000604	1/2-13x1" USS SOC HD CAP S.S.
6	2	002940	G2 RUBBER BUMPER
7	2	009042	G2 SUB ASSEMBLY BELTING 21-3/8"
8	8	000620	1/4-20X1/2" PN HD TY FS(G2)
9	4	002879	.75"DIA.x2.109"PIN w/FLAT HEAD KEEPER(G2)
10	4	002025	3/4"EXTERNAL SNAP RING (G2) PLATED
11	4	002109	.75"IDx1"ODx1.5"BEARING (G2)
12	4	000756	1/4-20x3/4" PHI FH TYPE F SS

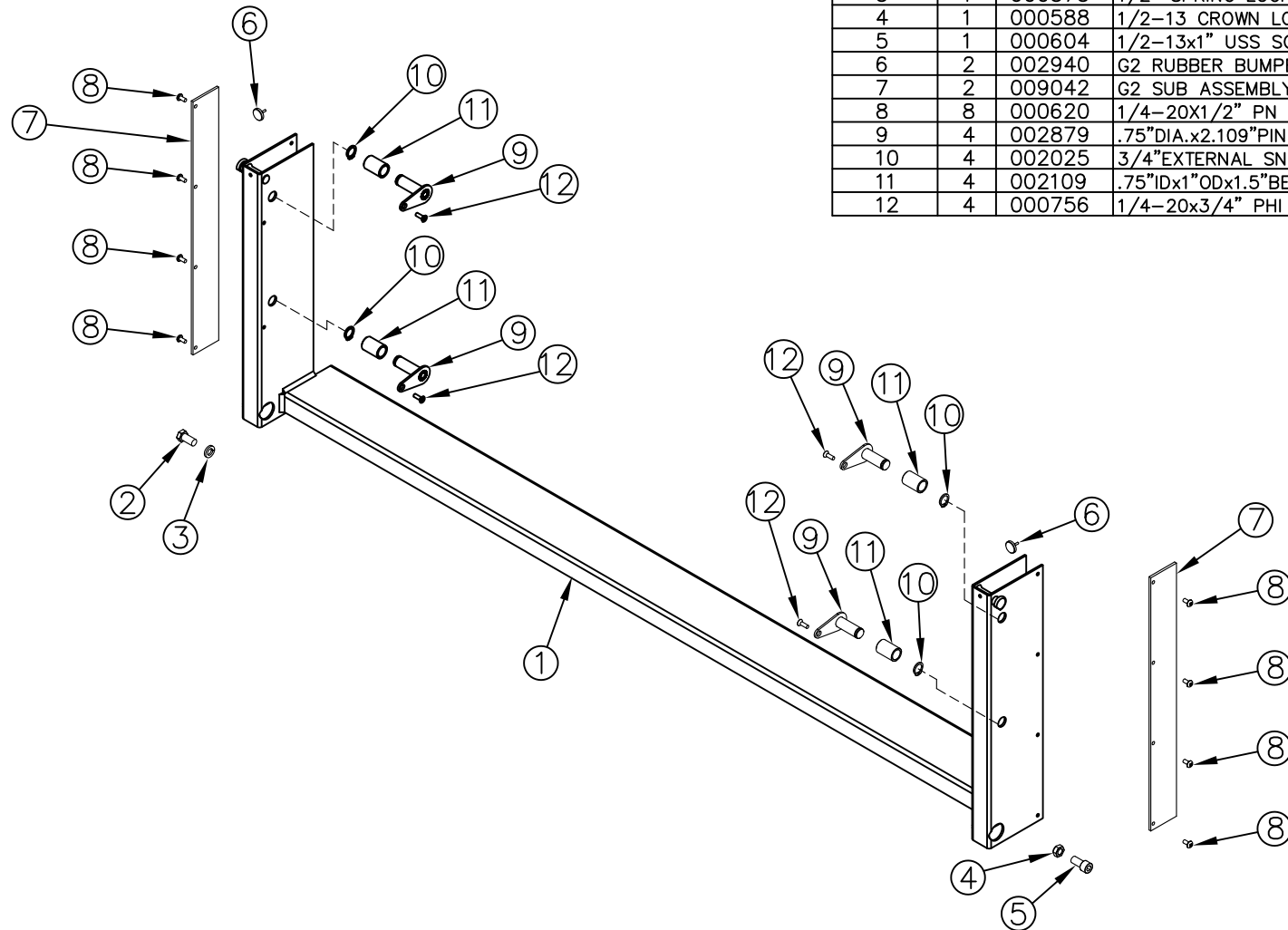

				THIRD ANGLE PROJECTION			FILENAME:		WOODBINE MFG. CO. BUS BROWN DRIVE WOODBINE, IOWA 51579															
							SYMBOLY PER ANSI Y14.5						NOTES:											
				<table border="1"> <thead> <tr> <th>DECIMAL</th> <th>2PLC</th> <th>3PLC</th> </tr> </thead> <tbody> <tr> <td>MACHINE SAW, DRILL</td> <td>.030</td> <td>.015</td> </tr> <tr> <td>SHEAR, PUNCH FORM</td> <td>.060</td> <td>.030</td> </tr> <tr> <td>TORCH, WELDING ROUGH CAST</td> <td>.090</td> <td>.060</td> </tr> </tbody> </table>			DECIMAL	2PLC	3PLC	MACHINE SAW, DRILL	.030	.015					SHEAR, PUNCH FORM	.060	.030	TORCH, WELDING ROUGH CAST	.090	.060	DRAWN BY: AAS	
DECIMAL	2PLC	3PLC																						
MACHINE SAW, DRILL	.030	.015																						
SHEAR, PUNCH FORM	.060	.030																						
TORCH, WELDING ROUGH CAST	.090	.060																						
				DRAWN/DATE 9/6/24		APPVD/DATE		TITLE G2 81-42 LOW PROFILE REPAIR SUB ASSEMBLY																
A	9/6/24	RELEASED TO PRODUCTION			AAS		3051	SALES CATEGORY		PRODUCT LINE	SCALE 1:12	FIN. WT.	PART NO. 18312											
REV.	DATE	CHANGE RECORD			BY	APPVD	ECN	DRAFT 2"		ANGULAR ±1"														