

ITEM NO.	QTY.	PART NO.	DESCRIPTION
1	1	010143	PLATFORM FRAME ASSEMBLY(92LND) G2-50
2	2	007015	INSERT HINGE PIN WELDMENT-LD
3	2	002109	G2 .75"IDx1"ODx1.5"BEARING
4	4	000578	3/4" SAE FLATWASHER
5	2	000576	1/2" SAE FLATWASHER
6	2	000588	1/2" CROWN LOCK NUT
7	2	004727	3/8" U-BOLT(SHORT)x16x7/8x1-1/2
8	4	000550	3/8-16 GR5 HEX NUT
9	4	000605	3/8-16 USS CROWN LOCK NUT
10	1	000551	1/2-13 GRADE 5 HEX NUT
11	2	000587	1/2-13x1" HHCS GR5
12	2	000573	1/2-13 SPRING LOCKWASHER
13	1	007433	DRIVER'S SIDE SQ. SPRING HOLDER
14	1	007435	PASS SIDE SQ. SPRING HOLDER(86-91)
15	2	002371	10GA.x1.13"x1.63" TUBE CAP(BR)

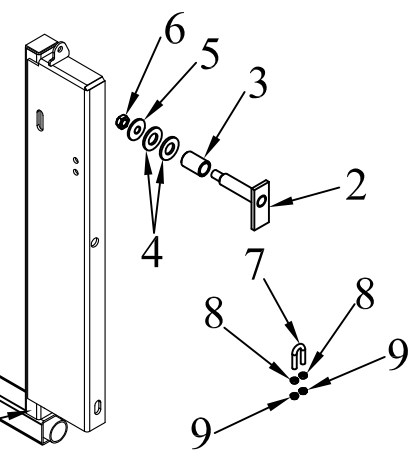

					THIRD ANGLE PROJECTION		FILENAME:		WOODBINE MFG. CO.															
							SYMBOLY PER ANSI Y14.5		BUS BROWN DRIVE															
					<table border="1"> <tr> <th>DECIMAL</th> <th>2PLC</th> <th>3PLC</th> </tr> <tr> <td>MACHINE SAW, DRILL</td> <td>.030</td> <td>.015</td> </tr> <tr> <td>SHEAR, PUNCH FORM</td> <td>.060</td> <td>.030</td> </tr> <tr> <td>TORCH, WELDING ROUGH CAST</td> <td>.090</td> <td>.060</td> </tr> </table>		DECIMAL	2PLC	3PLC	MACHINE SAW, DRILL	.030	.015	SHEAR, PUNCH FORM	.060	.030	TORCH, WELDING ROUGH CAST	.090	.060	DRAWN BY. JCB		NOTES:		WOODBINE, IOWA 51579	
DECIMAL	2PLC	3PLC																						
MACHINE SAW, DRILL	.030	.015																						
SHEAR, PUNCH FORM	.060	.030																						
TORCH, WELDING ROUGH CAST	.090	.060																						
					DRAWN/DATE 1/25/10		712-647-2050																	
					APPVD/DATE		TITLE																	
					SALES CATEGORY		G2 REPLACEMENT OUTER PLATFORM ASSEMBLY(92LD)																	
REV.	DATE	CHANGE RECORD			BY	APPVD	ECN	PRODUCT LINE	SCALE	FIN. WT.	PART NO.													
A	1/25/10	DRAWN IN AUTOCAD			JCB		259		1:12	50.84	10465													

THE INFORMATION HERE IS CONFIDENTIAL AND MUST NOT BE USED IN ANYWAY DETRIMENTAL TO THE INTEREST OF WOODBINE MFG.