

Cantilever Series Mounting Instructions

Ford Transit Extended Body (AG)-
2015-present

Preparing the Gate

1. **Remove** the platform, mounting kit, and bridge assemblies, which are banded to the main assembly. Leave the banding that holds the folding cylinder to the main assembly.
2. **Verify** mounting kit, liftgate, and other components (Figure 1 and Table 1).

Table 1: Parts List.

QTY.	PART NO.	DESCRIPTION
1	13753	Main Assembly
1	10587	71" Split Platform Assembly
	11168	52" Split Platform Assembly
1	13917	Mounting Kit-Transit (AG)
1	13858	Frame Bracket-Extended
1	13919	Bridge Assembly - Right
1	13949	Bridge Assembly - Left
1	10026	Upper Platform Cover
1	10298	Lower Platform Cover
1	14004	Transit Rear Cover

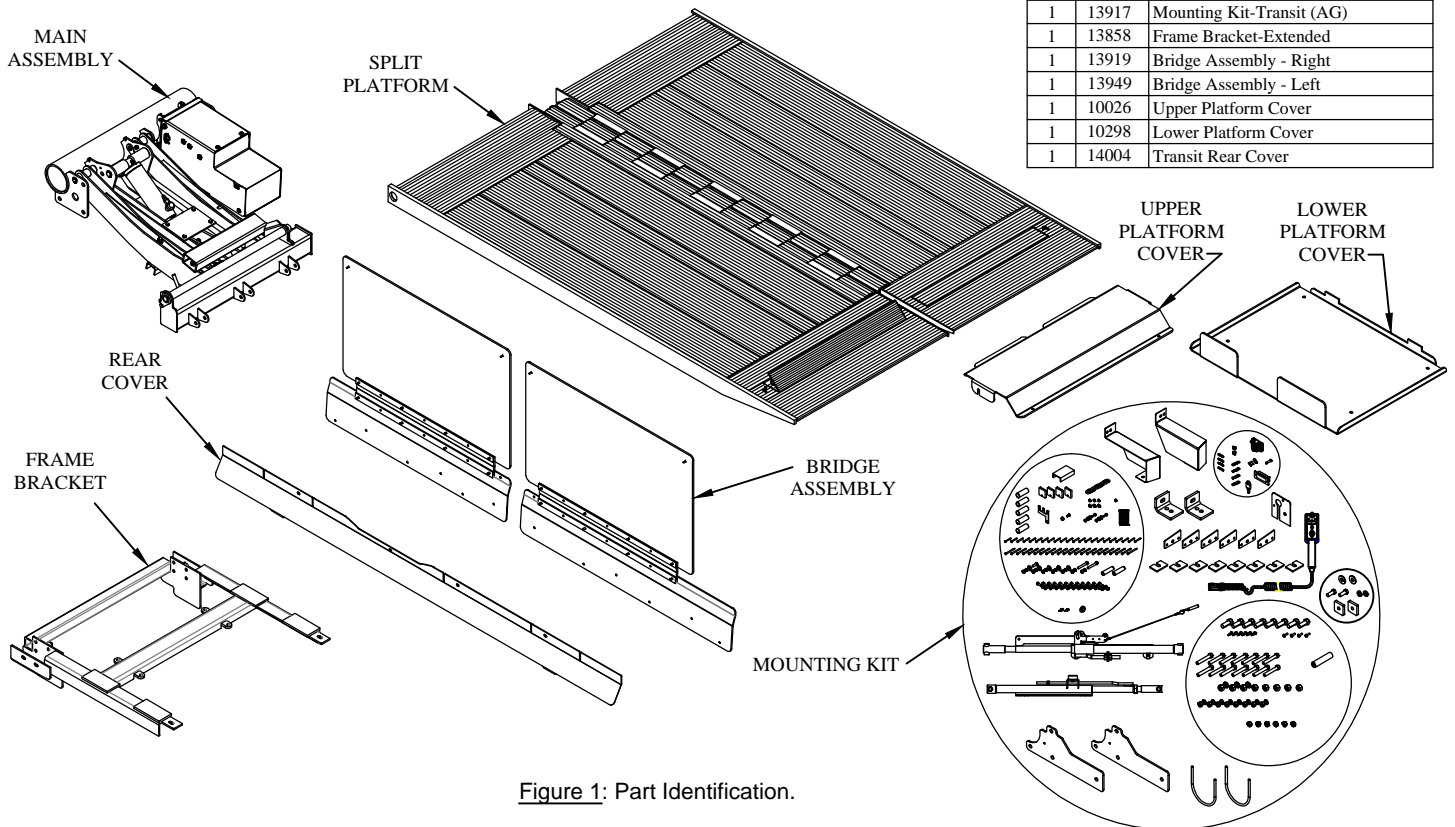

Figure 1: Part Identification.

3. **Remove** the pump box top cover by removing the three (3) screws, and verify that the vent plug is installed (Figure 2).
4. **Unscrew** the solid plastic plug from the pump reservoir and **Install** the vent plug provided, if not already installed (Figure 3).
Note: The hydraulic system has already been filled with the proper amount of hydraulic oil so **do not** add any oil at this time.
5. **Install** the 5-link chain on the driver side bracket plate with a 3/8" x 1" bolt, flat washer, lock washer, and nut (Figure 4).
Only the bolt head goes on the inside of the bracket plate.

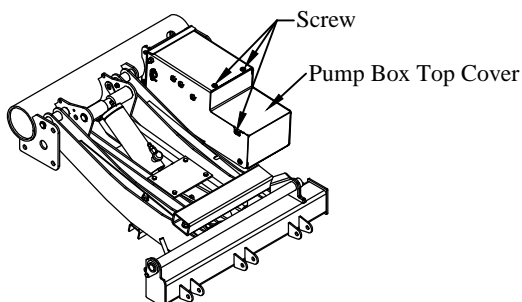

Figure 2: Pump box cover screws.

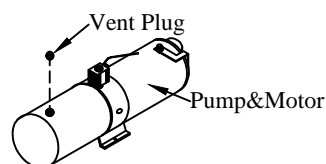

Figure 3: Vent plug installation.

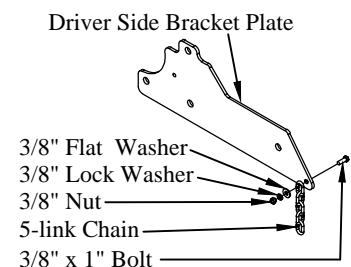

Figure 4: Chain-up feature hardware.

Cantilever Series Mounting Instructions

Preparing the Gate (continued)

- 6. Install** the fold up stop on the rod on the main assembly (Figure 5).
- 7. Install** the platform plates on the platform with the provided 5/16" x 1" bolts, lock washers, and nuts. The wide end goes toward the platform hinge. Note the location of the two (2) flat washers in place of lock washers (Figure 6).
- 8. Install** each bracket plate on the main assembly using three 5/8" x 1-1/4" bolts, lock washers, and nuts. The bolt head and lock washer should be on the outside (Figure 7).
- 9. Attach** each angle bracket to a bracket plate using a 5/8" x 1-1/4" bolt, and lock nut. Use the bottom hole of the angle bracket (Figure 7).

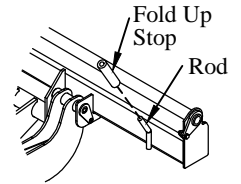

Figure 5: Platform stop location.

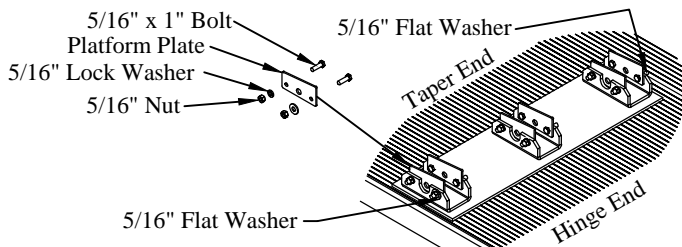

Figure 6: Platform plate location.

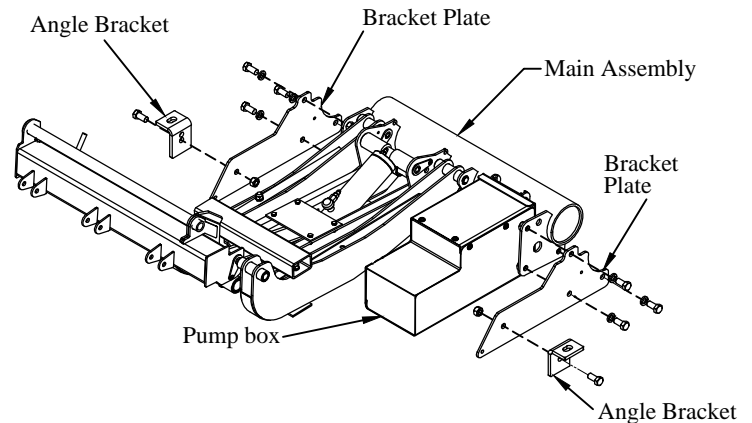

Figure 7: Bracket plate locations.

Preparing the Van

- 1. Support** the rear step/bumper and hitch to keep them from falling while removing the mounting bolts.
- 2. Remove** the hitch, if equipped.
- 3. Remove** the rear step/bumper, which consists of a steel structure and plastic cover.
- 4. Remove** the spare tire using the tools supplied with the vehicle or a 3/4" drive extension. The spare tire will have to be stored in another location after gate installation.
- 5. Remove** the spare tire crank mechanism and center spare tire guide.

Note: The hitch, rear/step/bumper, and spare tire cannot be remounted after the liftgate is installed.

Note: The rear tailpipe does not need to be removed for extended vans.

- 6. Attach** the rear end of the frame bracket to the van frame using eight (8) supplied 1/2" x 3-3/4" bolts, lock washers, and nuts.
- 7. Attach** the front end of the frame bracket to the van frame using two (2) M12 bolts. For dual rear wheel vans use existing rear spring shackle M12 bolts. For single rear wheel vans use supplied M12 bolts, flat washers, lock washers, and 3/8" spacers.

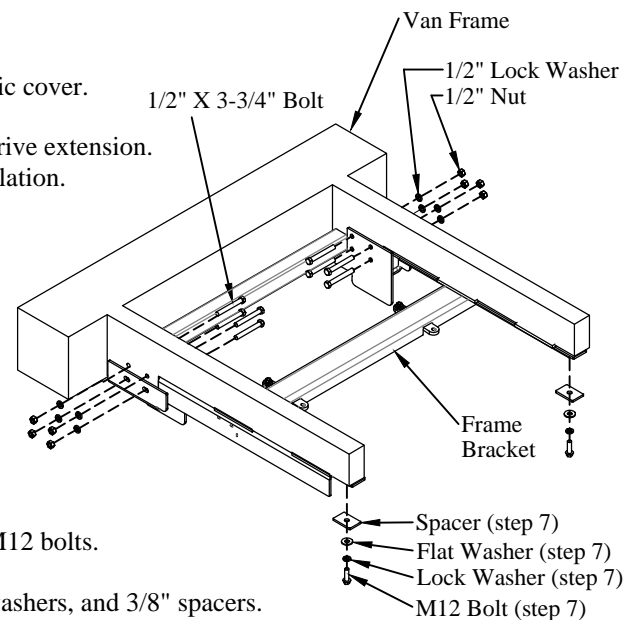

Figure 8: Frame bracket location.

Cantilever Series Mounting Instructions

Installing the Main Assembly

- 1. Securely Position** the main assembly onto a lifting device, pallet, or other structure so that it cannot tip or fall. It must be supported by the bracket plates, not the lift arms.
- 2. Position** the main assembly under the van.
Make sure there are no wires or hoses in a position where they may be pinched.
- 3. Raise** the main assembly into position below the van frame. Do not lift by the lift arms, otherwise the brackets may not reach.
- 4. Attach** the 3/8" U-bolts to the front channel in the frame bracket with the supplied four (4) flat washers, lock washers and nuts.
- 5. Attach** each angle bracket to the 5/8" bolts on the frame bracket with the supplied washers and lock nuts (Figure 9).
- 6. Add** spacers between the angle bracket and the frame bracket to bring the rear of the main assembly as high as possible without contacting the van (Figure 9).
- 7. Remove** the lifting device, pallet, or other structure from the main assembly.
- 8. Install** the rear cover on the rear of the van (Figure 10).
Reuse the vehicle bumper screws and bolts.
- 9. Install** the left and right bumper covers. Use the supplied #12 self-drilling screws, 1/4" bolts, washers, and nuts, and factory bumper screws (Figure 10).

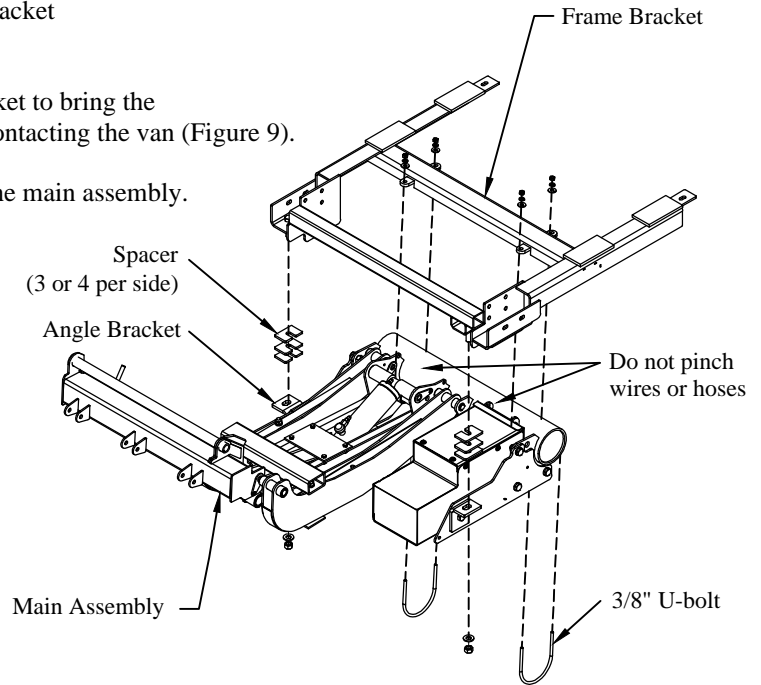

Figure 9: Main assembly position on frame.

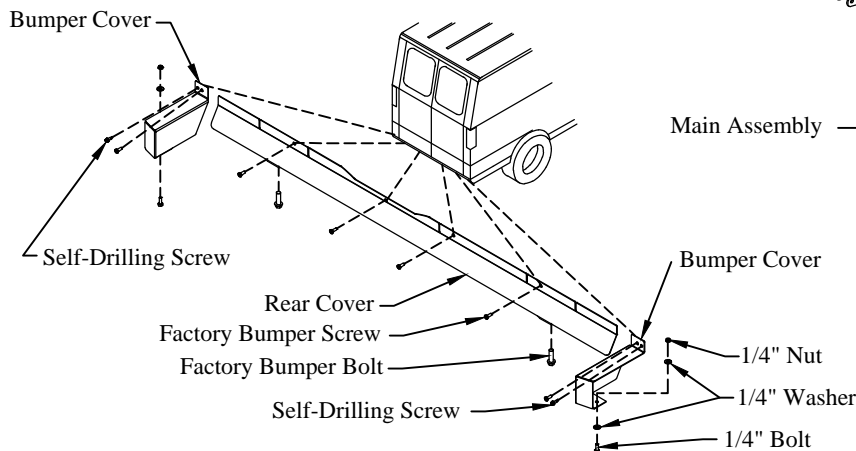

Figure 10: Rear cover hardware location.

Cantilever Series Mounting Instructions

Routing the Power Cables

Note: 2020+ Ford Transit

Connect the liftgate positive cable directly to the battery, not the Customer Connection Points (CCP) for these model years of Transit. Electrical loads controlled by the van's load-shed signal, such as the CCP, may temporarily be turned off by the load-shed switch while the liftgate is operated.

Note: 2015-2019 Ford Transit

Ford recommends using the vehicle Customer Connection Points (CCP) to power the liftgate. Vehicle option 67C-User Defined Upfitter Switches, provides three (3) 60 amp CCP, which can be combined into one 180 amp connection. If three (3) CCP are not available, Ford part number BK2Z-14S411-A adds the additional CCP. If neither of these options are available, large loads can be connected to an empty M6 stud on the positive battery terminal using the supplied M6 lock nut (Ford Bulletin Q-226R2).

1. **Install** the circuit breaker on the floor behind the driver seat, near the battery, leaving enough room for the power cables to be installed and so that the circuit breaker can easily be reset.
2. **Check** for obstructions before drilling.

Note: Any time a hole is drilled in the vehicle, apply rust preventative to the bare metal.

3. **Drill** and **Deburr** a 1-1/4" hole in the floor next to the driver seat in the location shown (Figure 11).
An alternate location will be needed if there is a trailer brake controller in the way.

Note: Follow the *Tommy Gate Recommended Electrical Wiring Guidelines* and wiring diagram (Figure 16) in the following steps.

4. **Route** the power cables under the vehicle from the liftgate, along the frame, to a location under the driver door (Figure 11).
Provide at least 12" extra of cable near the pump to allow for gate movement and for later service.
5. **Pull** the power cables through the drilled 1-1/4" hole in the floor, using the supplied grommet.
6. **Separate** the positive(+) and negative(-) leads.
7. **Cut** the positive(+) lead to the length required to reach the auxiliary (AUX) terminal of the circuit breaker.
8. **Cut** the remaining positive(+) lead long enough to reach from the circuit breaker battery (BAT) terminal to the positive 12 volt connection point for your application (see notes at beginning of this section).
9. **Cut** the negative(-) lead to the length required to reach a vehicle ground point on the floor between the front seats (Figure 11).

IMPORTANT: The pump and motor unit for this lift can require significant electrical power at 12 volts D.C.
Be sure that the negative (-) ground lead is securely connected to a sufficient vehicle ground point.

10. **Install** the copper lugs on all required ends. Make sure the copper lugs will fit flush with the connection surfaces.

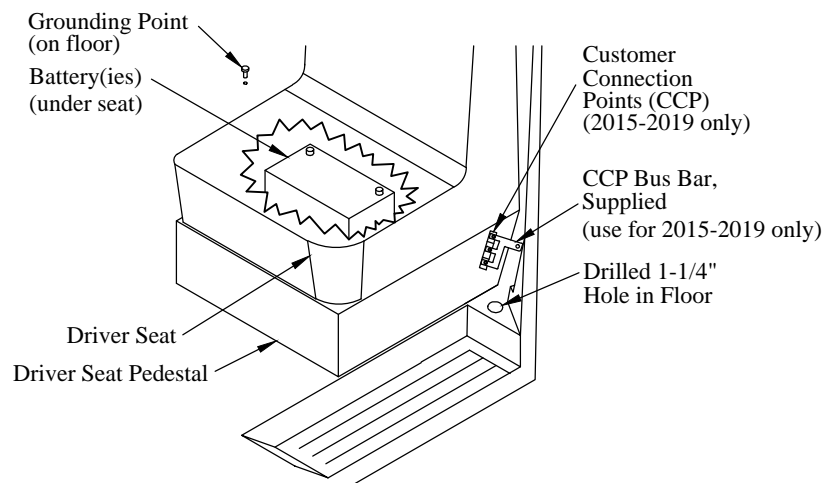

Figure 11: Power connection locations.

Cantilever Series Mounting Instructions

Routing the Power Cables (continued)

11. **Connect** the negative(-) lead to a vehicle ground point on the floor between the front seats. (Figure 11).
12. **Connect** the circuit breaker (Figure 16). Use the supplied heat shrink tubing.
13. **Check** for obstructions before drilling.
14. **Attach** the circuit breaker cover using the supplied self-drilling screws (Figure 12).
15. **Connect** the positive(+) lead to the M6 stud on the positive battery clamp. Reuse the M6 lock nut, when possible (Figure 13).
For 2015-2019, see Ford Bulletin Q-226R2 and do not connect to the stud occupied by the alternator sensing circuit.
16. **Apply** sealant to holes drilled for power cables.
17. **Skip** Steps 18-21 for 2020+ Transit.
Complete Steps 18-21 only if using the CCP bus bar for 2015-2019.
18. **Remove** the plastic cover from the CCP on the driver seat pedestal (Figure 11).
19. **Install** the supplied bus bar on the CCP studs using three (3) supplied M5 nuts and star washers.
The bus bar combines three (3) 60 amp connections into one 180 amp connection point.
20. **Connect** the positive(+) lead to the CCP bus bar. Use the supplied 5/16" bolt, lock nut, and two (2) pieces of heat shrink tubing to cover the cable connection to the bus bar.
21. **Install** the plastic CCP cover on the bus bar cable connection. The cover will need to be trimmed for bus bar clearance.

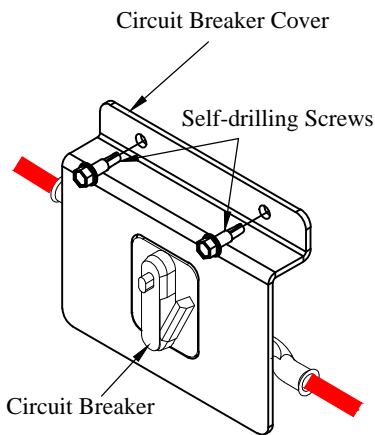

Figure 12: Circuit breaker cover.

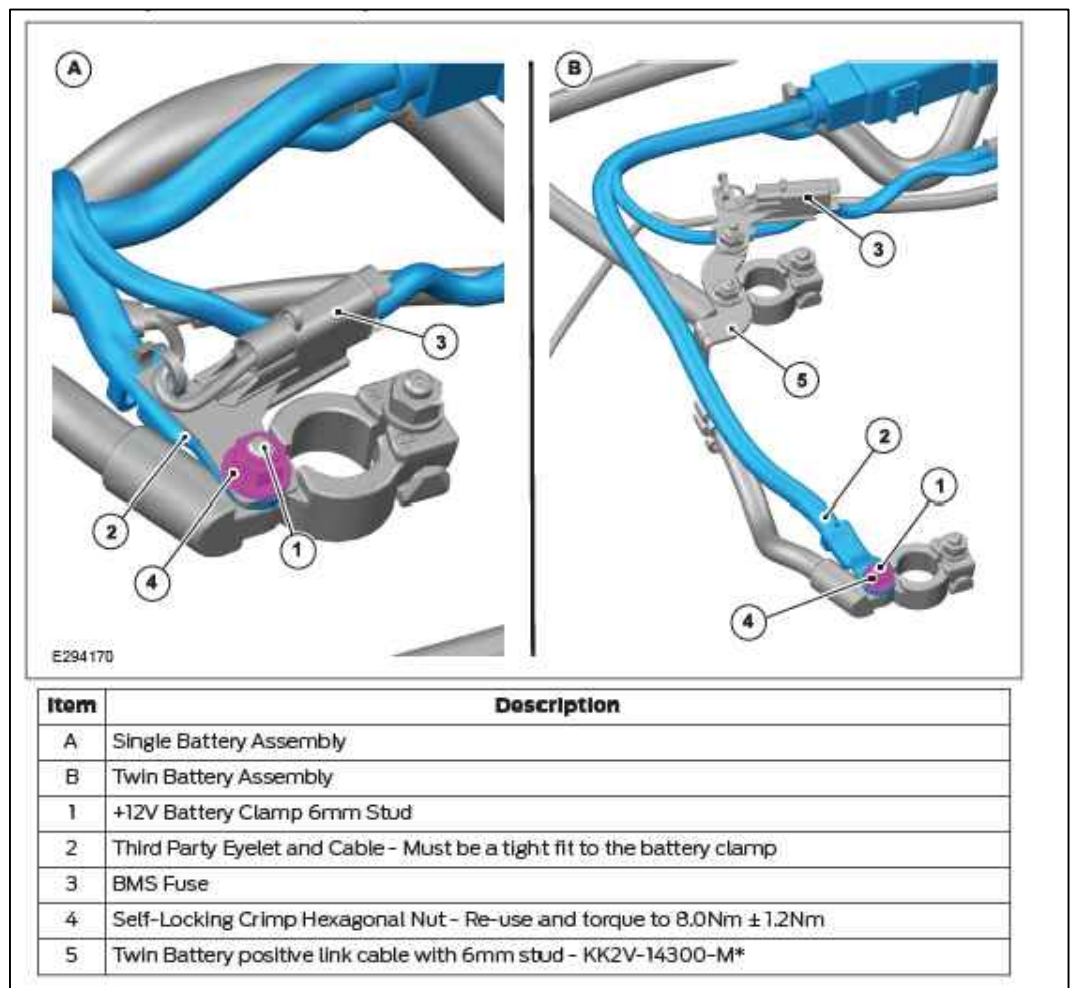

Figure 13: Battery diagram from 2020 Ford Transit Body and Equipment Mounting Manual (BEMM).

Cantilever Series Mounting Instructions

Installing the Pendant Control

Note: Any time a hole is drilled in the vehicle, apply rust preventative to the bare metal.

Note: The driver side rear door cannot be opened unless the liftgate is partially lowered.

1. Locate an existing hole in the passenger side van wall to mount the toggle switch and pendant control female connector.
Make sure there is enough depth behind the bracket for the toggle switch and female connector.
The pendant control should not extend into the door opening.

2. Connect the control cable to the pump box via the amp connector (if it is not hard wired)

3. Disconnect the wires from the female connector if needed to route the control cable in the next steps.

4. Route the control cable from the pump box to the mounting bracket through a rubber access plug in the bottom of the rear cross member. Provide at least 12" of extra cable near the pump box for later service.
Follow the *Tommy Gate Electrical Guidelines*.

5. Reconnect the female connector wires if previously disconnected (Figure 15).

6. Install the fold/unfold toggle in the 1/2" hole in the mounting bracket.

7. Position the mounting bracket over the hole in the van wall (Figure 14).
Make sure that the 1/2" and 1-1/4" holes are not obstructed.

8. Mark the two (2) small holes to be drilled in the van wall using the mounting bracket as a guide.

9. Check for obstructions before drilling in the next step.

10. Drill two (2) 13/64" holes in the locations previously marked.

11. Route the two-conductor wire from the liftgate to the toggle switch along the same path as the control cable. Provide at least 12" of extra wire near the pump box for later service. Follow the *Tommy Gate Electrical Guidelines*.

12. Connect the wires to the toggle switch (Figure 16).

13. Position the female connector in the mounting bracket.

14. Install the supplied two (2) 1/4-20 self-tapping screws, through the female connector, through the mounting bracket, and into the van wall.

15. Secure any loose or excess wires to the main lift assembly away from moving parts.

16. Connect the pendant control to the female connector.

17. Reinstall the rubber access plug in the bottom of the rear cross member.
A small cut from one side of the rectangular plug will accommodate the wires.

18. Apply sealant to the cut in the rubber access plug.

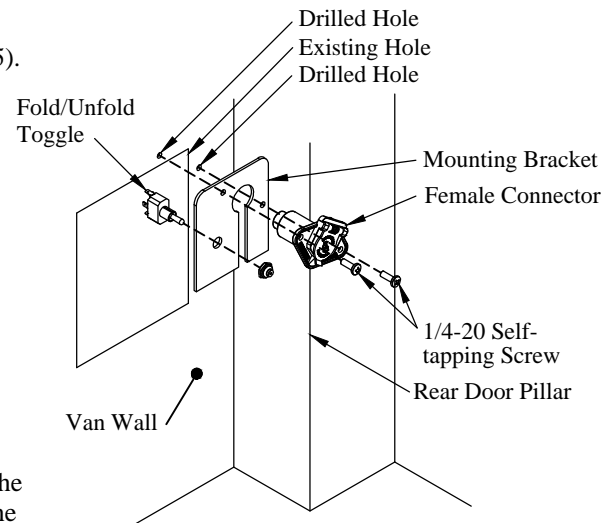
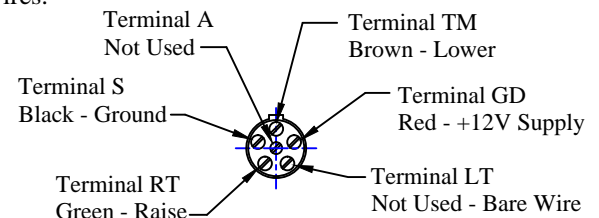

Figure 14: Pendant control female connector location.



Note: This is a front (terminal end) view, not a rear (wire end) view.

Figure 15: Female connector wiring.

Cantilever Series Mounting Instructions

!!! PLEASE READ AND FOLLOW ALL DIRECTIONS BEFORE PROCEEDING !!!



NOTE !!! IF GATES ARE NOT WIRED IN ACCORDANCE WITH THIS DIAGRAM YOUR WARRANTY WILL BE VOID.



WELDING NOTE !!! DISCONNECT ALL BATTERY CABLES. ALWAYS DISCONNECT THE GROUND CABLE FIRST. ATTACH THE WELDING GROUND TO THE VEHICLE RATHER THAN THE LIFTGATE.

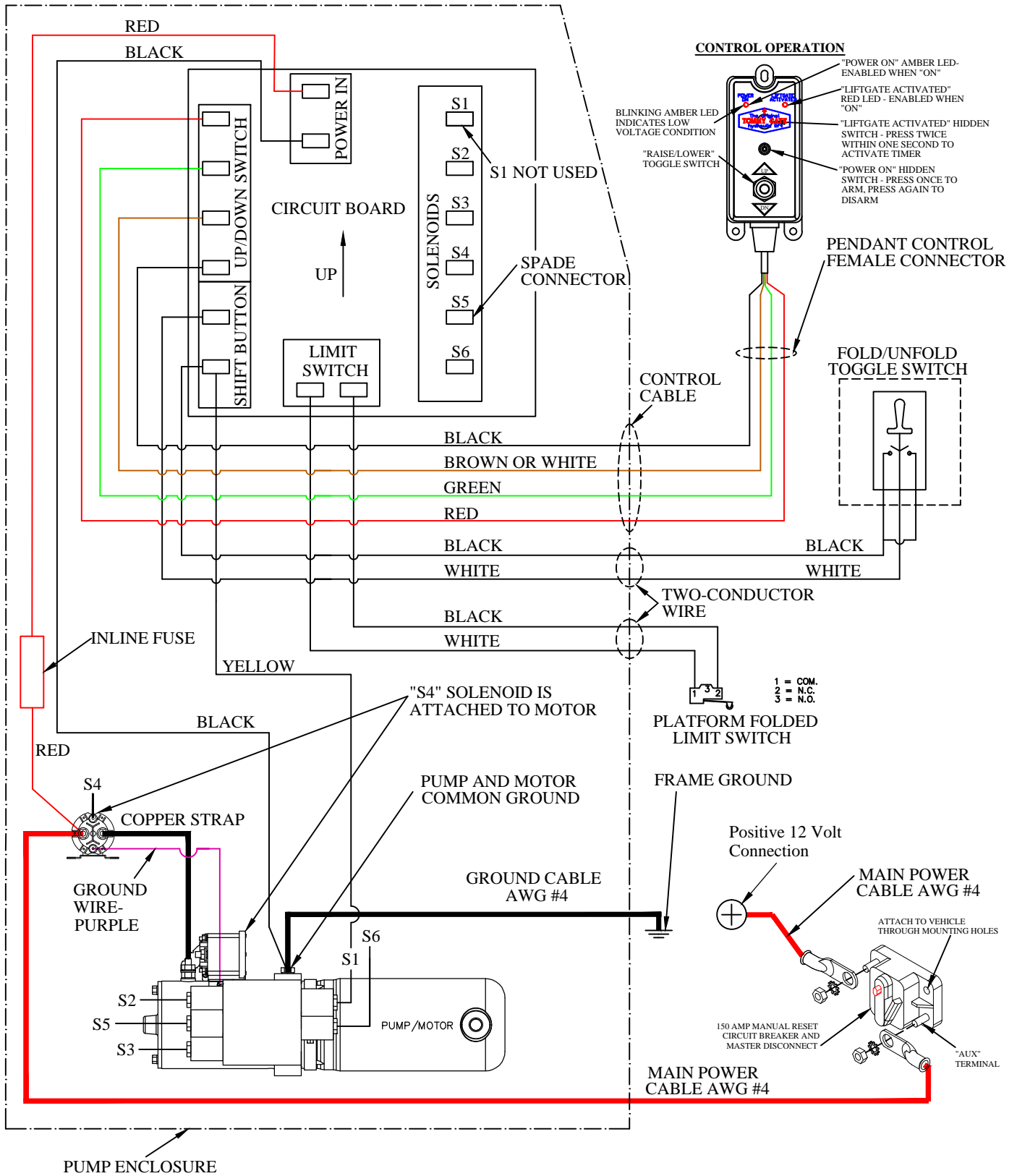

Figure 16: Wiring diagram.



POWER UNIT CONTROL CIRCUIT

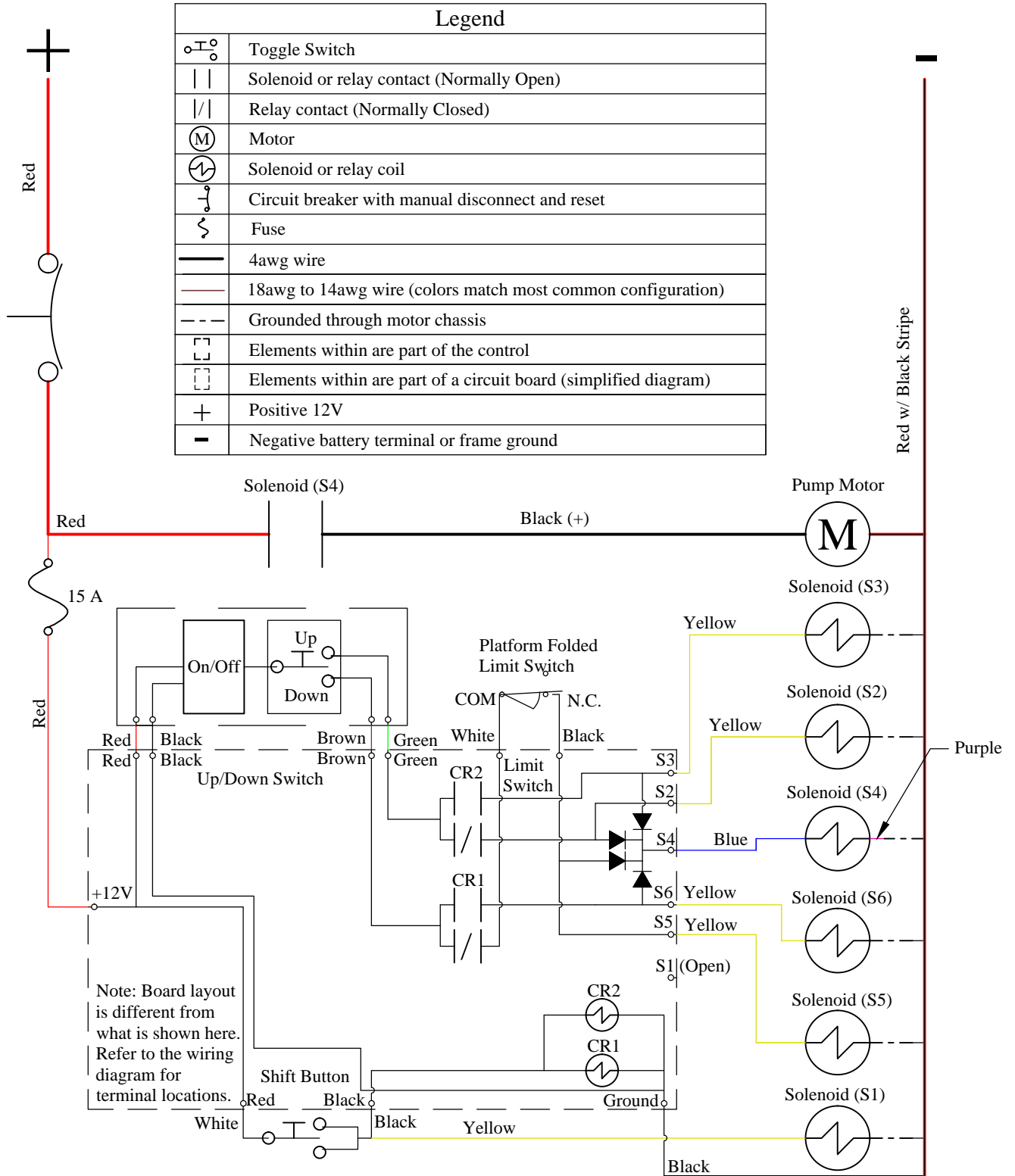

Figure 17: Power unit control circuit.

Cantilever Series Mounting Instructions

Installing the Platform

CAUTION: Keep all foreign objects (body parts, tools, load weights, etc) away from the liftgate main assembly and away from pinch points at all times when operating the liftgate.

- 1. Install** the support arms on the main assembly, using a 1/2"x3-3/4" GR 8 bolt and lock nut, do not tighten. The threaded end of the support arm goes toward the main assembly (Figure 18).
- 2. Install** the folding cylinder on the main assembly, using a 1/2"x3-3/4" GR 8 bolt and lock nut, do not tighten. The threaded end of the cylinder goes toward the main assembly (Figure 18).
- 3. Remove** the hinge tube from the main assembly. Save the 5/16" screw, lock washer, and nut, they will be reused.
- 4. Install** the limit switch bracket on the passenger side support arm with two (2) #12 self-threading screws. See Figure 19 for bracket shipping location. Make sure that the limit switch is not in the pushed position.
- 5. Position** the platform on the main assembly. The limit switch wire goes under the platform.
- 6. Support** the platform near the taper end to keep it from falling.
- 7. Insert** the hinge tube through the platform and main assembly from the driver side.
- 8. Install** the 5/16" screw, lock washer, and nut in the hinge tube keeper.

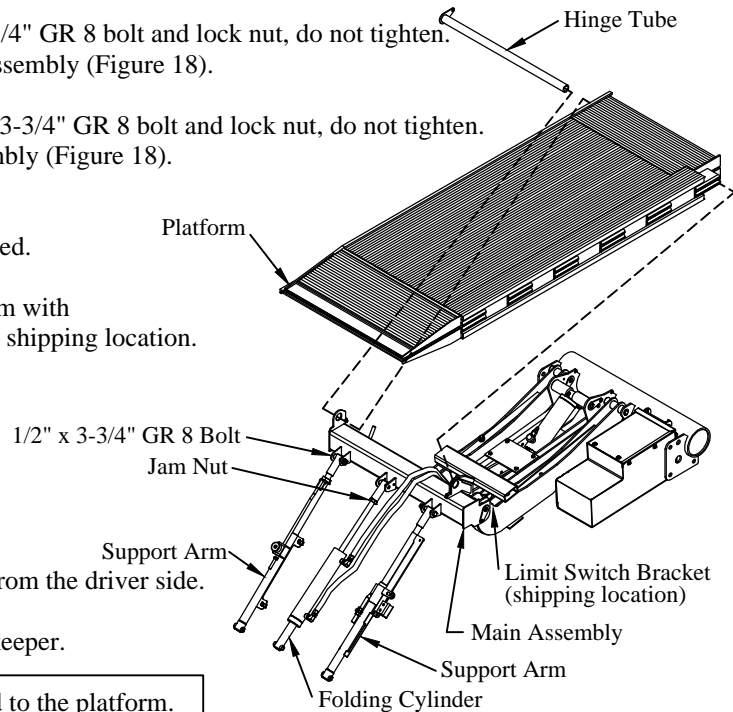

Figure 18: Platform parts location.

CAUTION: Do not operate the folding cylinder until it is bolted to the platform.

- 9. Raise or Lower** the lift until the folding cylinder can be bolted to the platform. The lift will lower only if the limit switch is not pushed.
- 10. Attach** the folding cylinder to the platform, using a 1/2" x 3-3/4" GR 8 bolt and lock nut, do not tighten.
- 11. Fold** the platform up partially, using the hydraulic fold function. Make sure the platform is folded in half before using the hydraulic fold function.
- 12. Attach** the support arms to the platform, using 1/2" x 3-3/4" GR 8 bolts and lock nuts, do not tighten.
- 13. Lower** the lift to the ground.
- 14. Verify** that all mounting bolts and bracket bolts have been installed.
- 15. Tighten** all liftgate mounting bolts, bracket bolts, and U-bolts.

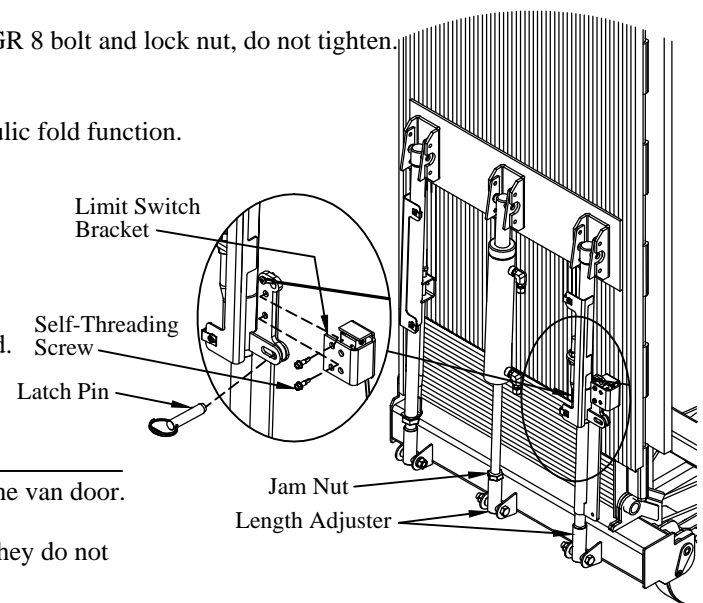

Figure 19: Platform latch and adjustment.

Adjusting the Platform

- 1. Verify** that the platform folds to a vertical position without hitting the van door.
- 2. Loosen** the 3/8" nuts on the driver side support arm (Figure 21) so they do not contact the stop bracket when the platform is folded.
- 3. Support** the platform to keep it from falling or hitting the van in the next steps (Figure 19).
- 4. Adjust** the folding cylinder for closed/vertical position, if needed.
 - a. Loosen** the jam nut (cylinder only).
 - b. Remove** the 1/2" x 3-3/4" bolt and nut.
 - c. Rotate** the length adjuster: "in" to close less or "out" to close more.
 - d. Reinstall** the 1/2" x 3-3/4" bolt and nut.

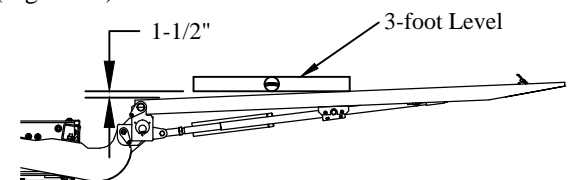

Figure 20: Platform position.

- 5. Unfold** the platform completely.

Cantilever Series Mounting Instructions

Adjusting the Platform (continued)

6. **Adjust** the passenger side support arm so that the platform is 1-1/2" from level over a 3-foot length (Figure 20). Adjustment similar to folding cylinder.
7. **Adjust** the driver side support arm so that both support arms carry the platform load equally. Adjustment similar to folding cylinder.
8. **Fold** the platform to the vertical position.
9. **Tighten** the lower 3/8" nut on the driver side support arm until it contacts the stop bracket (Figure 21).
10. **Unfold** the platform partially.
11. **Tighten** the lower 3/8" nut on the driver side support arm an additional half turn.
12. **Tighten** the second 3/8" nut on the driver side support arm against the lower 3/8" nut.
13. **Loosen** the adjustment nuts on the passenger side support arm (Figure 21).
14. **Fold** the platform to the vertical position.
15. **Align** the latch slots/holes on the passenger side support arm.
16. **Insert** the latch pin into the aligned slots/holes on the passenger side support arm.
17. **Tighten** the adjustment nuts on the passenger side support arm.
18. **Verify** that all bolts have been re-installed and the cylinder jam nut is tight.

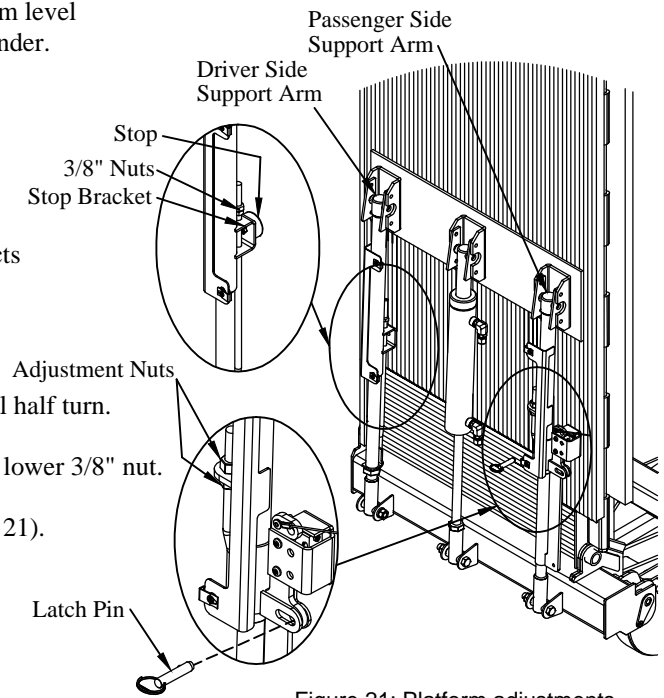
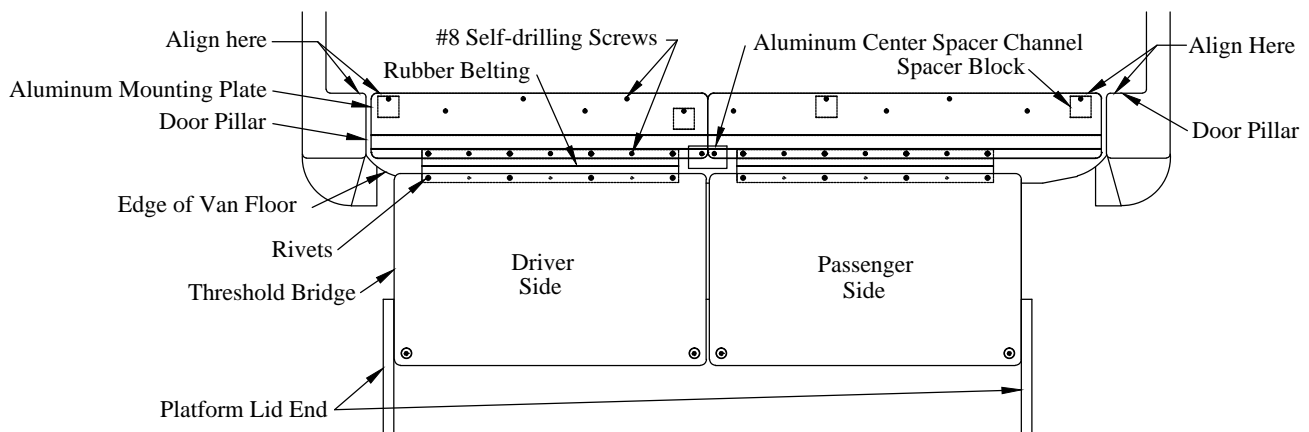

Figure 21: Platform adjustments.

Installing the Threshold Bridge

1. **Lower** the platform until the rear doors can be opened.
2. **Open** the rear doors of the van.
3. **Raise** the platform to the top of its travel.
4. **Remove** the factory installed, plastic threshold from the vehicle. This threshold will not be reused.
5. **Position** the driver side threshold bridge across the threshold (Figure 22).
Align the aluminum mounting plate on the bridge with the metal door pillar.
Align the left side of the bridge with the inside of the platform lid end.



Note: Threshold Bridges are not centered in van.

Figure 22: Threshold bridge location.

Cantilever Series Mounting Instructions

Installing the Threshold Bridge (continued)

6. **Position** the aluminum center spacer channel under the threshold bridge (Figure 22).
The open part of the C-channel goes down.
7. **Position** a 3/8" thick spacer block between the threshold bridge and the floor for support in areas where a screw will be located over a void.
8. **Position** the passenger side threshold bridge across the threshold (Figure 22).
Align the aluminum mounting plate on the bridge with the driver side bridge and the metal door pillar.
Align the right side of the bridge with the inside of the platform lid end.
The threshold bridges will not be centered in the van opening.
9. **Position** a 3/8" thick spacer block between the threshold bridge and the floor for support in areas where a screw will be located over a void.
10. **Pre-Drill** partially through thick floors (not sheet metal) with 3/16" drill bit to aid self-drilling screws in next steps.
Do not drill through the sheet metal floor.
11. **Attach** the driver side threshold bridge to the van floor using the supplied eleven (11) #8 x 1-1/4" or 2" self-drilling screws.
12. **Attach** the passenger threshold bridge to the van floor using the supplied eleven (11) #8 x 1-1/4" or 2" self-drilling screws.

Finishing the Liftgate Installation

1. **Install** the "Do's and Do Not's" decal in a highly visible area in the vehicle cab. This decal is with the Owner's / Operator's Manual.
2. **Pull** any excess fold cylinder hose toward the underside of the van.
Do this with the platform in the raised and stored position. Make sure the hose will not get pulled, pinched, or kinked during operation.
3. **Install** the upper aluminum cover on the lower 5/16" support arm bolts.
5/16" flat washers should have been installed previously (Figure 23).
4. **Drill** two (2) 13/64" holes in the platform, using the holes in the aluminum cover as a guide.
5. **Install** two (2) 1/4-20 self-tapping screws in the drilled holes.
6. **Install** the lower aluminum cover using four (4) 1/4-20 self-tapping screws.
7. **Verify** that all mounting bolts and nuts have been installed and tightened.
8. **Secure** the limit switch wire to the support arm and limit switch bracket using two (2) plastic zip ties. This should be done with the platform unfolded.
9. **Adhere** decal (PN 10476) to the exterior bottom right corner of the driver side rear door (Figure 24).

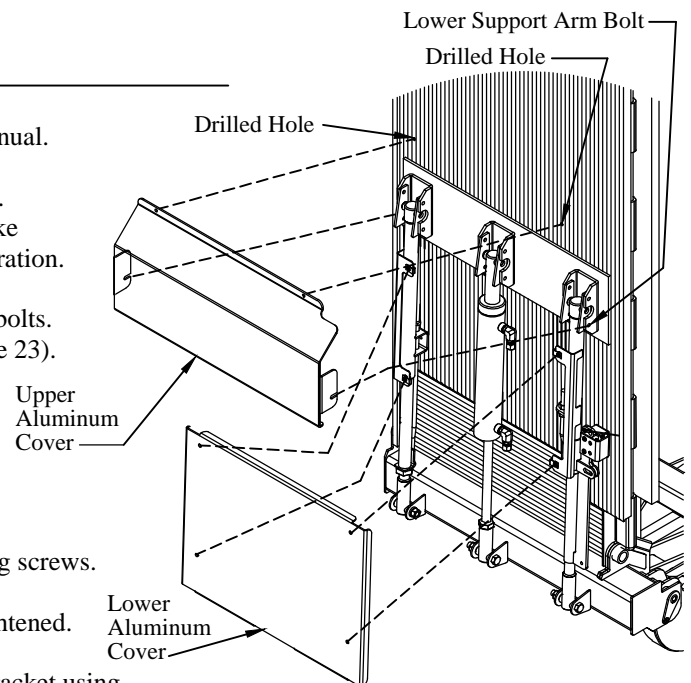

Figure 23: Aluminum cover installation.

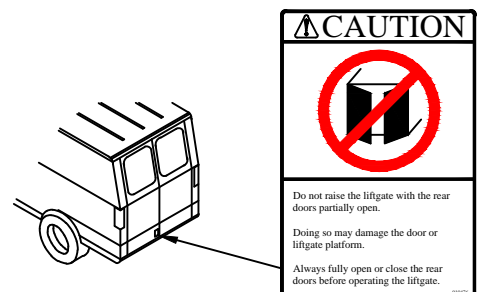

Figure 24: Caution decal location.

Cantilever Series Mounting Instructions

Testing the Operation of the Liftgate

CAUTION: Keep all foreign objects (body parts, tools, load weights, etc) away from the liftgate main assembly and away from pinch points at all times when operating the liftgate.

1. **Check** operation of the safety control for proper lift operation.
Be sure the control shuts off automatically after 90 seconds of not being used.
2. **Raise** and **Lower** the unloaded platform on a flat surface looking for proper operating speed and alignment with the ground.
The lift should not lower until the gate is partially unfolded.
3. **Load** the platform with the rated capacity and **Measure** the time necessary to raise the platform.
The platform should be fully raised within 15 seconds.
4. **Examine** the platform for any downward creep.
5. **Time** the lowering operation with the platform still loaded. The platform should be fully lowered and tilted within 10 seconds.
6. **Remove** the load from the platform and
Examine the liftgate and vehicle for any problems such as hydraulic oil leaks, loose wiring, etc.
7. **Reinstall** the pump cover.
8. **Fold** the platform in half.
9. **Raise** and **Fold** the platform using the hydraulic fold function.
10. **Insert** the latch pin into the storage hole (Figure 25).
11. **Insert** the locking pin through the hole in the passenger side support arm (Figure 25).
12. **Lock** the padlock through the hole in the locking pin (Figure 25).
13. **Place** Owner's / Operator's Manual and padlock keys in the vehicle.

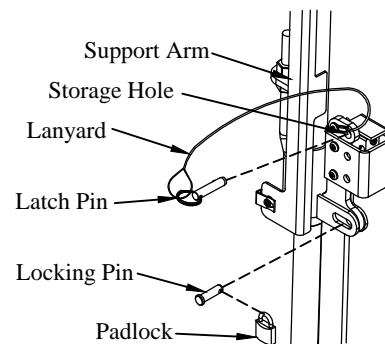

Figure 25: Platform lock.

Painting the Liftgate (if needed)

Your Tommy Gate has been primed with a gray polyurethane and painted with a black semi-gloss polyurethane topcoat to protect it from the environment. No additional paint is required unless shipping or installation damage or outdoor storage exposure has deteriorated the Tommy Gate paint. **Tommy Gate will not be responsible for shipping or installation damage or outdoor storage exposure that has marred or otherwise deteriorated the Tommy Gate paint.**

If you need to refinish the liftgate you should do the following:

1. **Remove** any dirt, oil, grease, salt, or other contamination by washing with a mild detergent solution.
2. **Rinse** thoroughly with fresh water and allow to dry.
3. Lightly **Scuff Sand** the Tommy Gate topcoat.
4. **Sand** and **Spot Prime** any area of the Tommy Gate paint that shows signs of damage or deterioration.
5. **Mask** off all safety decals, cylinder shafts and vents before painting.

WARNING: Paint over spray on the cylinder shaft(s) or vent(s) will damage the cylinder seals and void warranty.

6. After proper cleaning and surface preparation, **Apply** desired finish coat per paint manufacturer's recommendations.
7. **Remove** the masking from the safety decals and cylinders.
8. **Check** to ensure that all decals are clean and legible. Additional decals are available from the factory, if needed.

WIRE ROUTING

- (1) When routing wires, avoid heat (above 180°F), abrasion, vibration, metal edges, screws, and trim fasteners. If such routings are not possible, protective devices must be used. If wires must cross a metal edge, the edge should be covered with a protective shield and the wiring fastened within 3 inches on each side of the edge.
- (2) Grommets must be used where wires pass through holes in sheet metal, castings, and / or frame rails. Do not bend wires in a radius smaller than 10 times the wire diameter.
- (3) Routing wires into areas exposed to wheel wash should be avoided. If this cannot be avoided protective shields are required to protect the wires from stones, ice, salt and water damage. Provide a drip loop to prevent moisture from being conducted into switches, relays, circuit breakers, and fuses.
- (4) Wires should be supported every 18 inches with plastic zip ties or rubber-lined clips.
- (5) Wires must be routed to clear moving parts by at least 3 inches unless positively fastened or protected by a conduit. If wiring must be routed between two members where relative motion can occur, the wiring should be secured to each member, with enough wire slack to allow flexing without damage to the wire.
- (6) Maintain at least a 6 inch clearance from exhaust system components. If this is not possible, high temperature insulation and heat shields are required. Existing OEM heat shields, insulation, and wire shielding must be maintained.
- (7) Do not route or attach electrical wires to fuel lines. Route electrical wires at least 1-1/2 inches away from the engine.

BATTERY, WIRE, TERMINALS, AND CONNECTORS

- (1) Wire attachments at the battery must be protected from tension loads so there is no undue strain on the battery terminals. Wires should be routed down rather than horizontally from the terminals with no sharp bends adjacent to the connections.
- (2) Battery power for your Tommy Gate should come directly from the battery or approved connection point through the supplied circuit breaker or fuse. The circuit breaker or fuse should be installed as close to the battery as possible.
- (3) Avoid splicing power cables. If splicing is necessary, the most durable splice joint will be bare metal barrel crimped, flow-soldered and covered with adhesive lined heat shrink tubing. Strip the wire ends making sure that individual conductor strands are not damaged. Use only rosin core solder, proper crimping tools, and wire with a gauge at least equivalent to the circuit being lengthened. Do not use electrical tape.
- (4) Battery cable terminals will be bare metal barrel crimped or flow-soldered and covered with adhesive lined heat shrink tubing.
- (5) Use wire connectors with locking features such as positive locking, inertia locking, bolt together, and soft mold-over with locking external retainers.

GENERAL

- (1) All frame contact areas must be wire brushed to bare metal, free of paint, dirt, and grease. Frame connections must be made using hardened flat washers under the bolt head and lock nuts. Corrosion preventive grease or compound is to be applied to the terminal area of the frame connection.
- (2) Frame cross members are not recommended as part of the ground return.
- (3) All circuit breakers and fuses should be located in one easily serviceable location with a means provided for identification of circuit function and current rating. If possible, avoid putting circuit breakers or fuses in the vehicle cab.
- (4) Before welding to the chassis disconnect the battery. Also disconnect the power train, engine, valve, and transmission control modules.
- (5) Do not alter vehicle ignition, starting, and / or charging systems. Do not reroute engine compartment wiring.
- (6) Full copper circuitry and standardized polarity grounds are recommended.
- (7) Never increase the rating of a factory installed fuse or circuit breaker.
- (8) Disconnect the battery negative (ground) wire prior to any vehicle modification.

Following the above guidelines will provide you with years of trouble free service. Failing to incorporate the above guidelines may result in a voided warranty. Non-compliance with the guidelines above may result in a failure of electrical components, shutdown of engines, loss of backup brake systems, and the possibility of fire.

Q-226R2



SVE BULLETIN

SPECIAL VEHICLE ENGINEERING – BODY BUILDERS ADVISORY SERVICE

E-Mail via Website: www.fleet.ford.com/truckbbas (click "Contact Us")

Toll-free: (877) 840-4338

QVM Bulletin: Q-226R2

Date: 20 October, 2014

Revised: 13 March, 2017

Revision	Update	Revision Date
Q-226R2	Added recommendation for vehicles requiring greater than 30 Amps	13 March, 2017

Accessing Battery Power on Transit

Models Affected: 2015 Transit – All models

Description: For modifications and equipment installations requiring B+ current loads greater than 30 Amps, the guidelines provided below should be followed.

NOTE: If a converter intends to add systems or accessories that will add significant electrical load (particularly at key off), then vehicles with twin High Performance Deep Cycle AGM batteries should be specified. The twin option is the standard heavy duty system for loads greater than 5mA continuous at key off or 30A at engine run. It is also recommended to upgrade to the heavy duty alternator option if the extra loads are continuously active at engine run and exceed 30A above standard Ford systems.

For Battery Power Less than 60 Amps

- Connect to the 1 x 60A Customer Connection Point (CCP) in the Pre Fuse Box (PFB)
- 1 x 60A MIDI fuse is present on all Transit vehicles (within the PFB in the driver seat pedestal).
- See the Transit Body and Equipment Mounting Manual (BEMM) for information regarding the use of the CCP's.

For B+ Battery Power Greater than 60 Amps

Vehicles with factory installed 3 X 60A Customer Connection Points (available with option 67C-Upfitter switches)

- Connect to the 3 x 60A Customer Connection Points on the driver seat pedestal.
- The CCP's are capable of providing up to a total of 180A.
- Refer to the BEMM for information regarding the use of CCP's

Vehicles without factory installed 3 X 60A Customer Connection Points.

Upfitters may order a Customer Connection Point kit through Ford dealers. The kit part number is:
BK2Z-14S411-A

This kit provides hardware for two additional 60 Amp CCP terminals, allowing the modifier to upgrade from the standard single 60 Amp CCP to three 60 Amp CCP's, for a total of 180 Amps.

For Battery Power Greater than 180A

Vehicles equipped with dual AGM batteries will have a single empty B+ battery post on the rear or second AGM battery (see figure 1). Upfitters wishing to connect to this terminal must adhere to the following guidelines:

- Use only a W520101-S437 nut to secure the aftermarket eyelet (M6 - Electrolytic zinc plate, trivalent chromate, and clear sealer, with integral torque control lubricant). **No other nut or finish may be used.**
- The additional cable eyelet must have a complete flush contact to the terminal and be fully secured.
- The nut must be torqued to **8Nm [+/- 1.2Nm]**.
- The additional battery connection must be protected with an appropriately sized fuse.

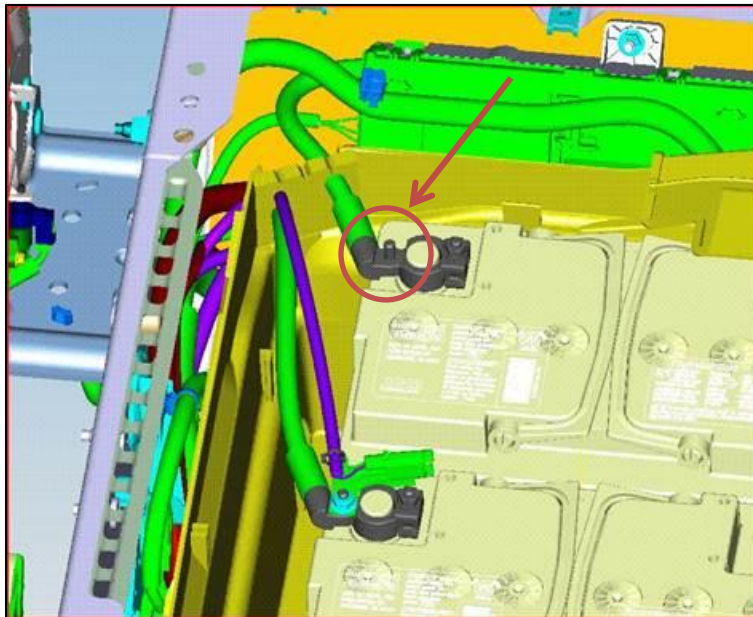

Fig. 1: Location of empty B+ battery post

Note: Single Battery variants

The B+ post on the single battery terminal can only accommodate a single terminal connection. The post is fully occupied by the alternator sense circuit, and cannot support an additional aftermarket terminal connection. **Any additional terminal connection to the single post may cause the charging system to malfunction or fail.** Upfitters connecting to the single battery post must provide an additional stud for their connection. All connection recommendations for the dual battery configuration shown above must be followed, and the additional connection and battery terminal must be protected with an appropriate battery terminal cover.

If you have any questions, please contact the Ford Truck Body Builders Advisory Service as shown in the header of this bulletin.