

INSTALLATION INSTRUCTIONS

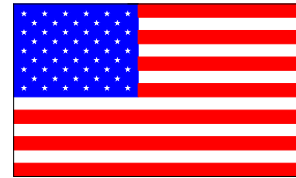

Woodbine, Iowa



Made in America

Railgate Series 2500 & 3000

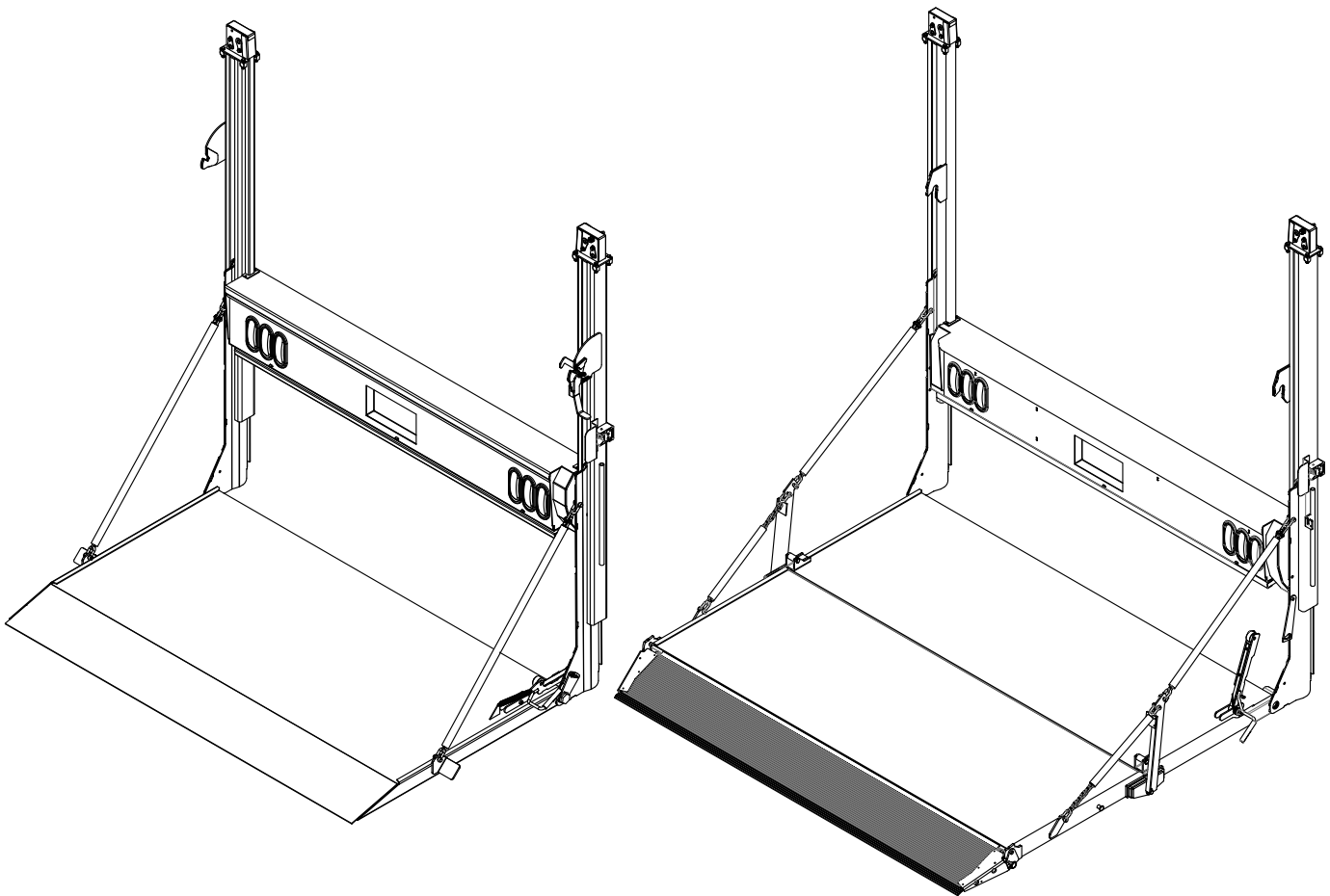

ESTIMATED INSTALLATION TIME: 8 HOURS



Before installing this Lift Gate, please observe the Vehicle Loading Limitations. These loading limitations are outlined in the Vehicle Owner's Manual and the Safety Compliance Certification Label located on the drivers door pillar.



Railgate Series Mounting Instructions

Step 1. The truck or trailer onto which the railgate is to be mounted must be built with certain structural components to ensure that it is capable of supporting both the railgate weight and the maximum load to be lifted by the railgate.

NOTE: A maximum length of 10 inches of unsupported upright is acceptable. Refer to Step 15 for specific instructions on support bracket recommendations.

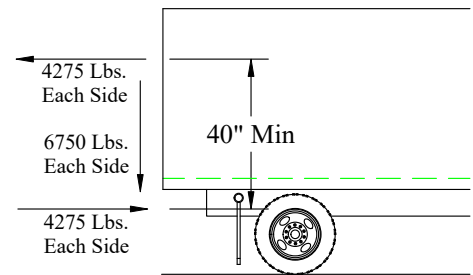

Step 2. If the truck or trailer is capable of supporting the load illustrated in Step 1, you may proceed to Step 3. However, if the truck or trailer is not capable of supporting the loads, you need to provide adequate reinforcement to the vehicle. The following examples are methods of providing reinforcement to the truck. If one of these methods, or another method of the installer's choice are used, the structural reinforcement should be thoroughly analyzed and/or tested before the truck or trailer, with the railgate attached, are put into service.

a) If the side wall cannot carry the required loads, or does not exist, use this method to support the liftgate. Be sure to use a channel, tube or angle to construct the reinforcing member if it is not in-plane with the upright. The reinforcing member should be constructed in a manner in which the uprights will not be twisted during railgate operation. When viewed from the top, the reinforcing member should extend directly forward of where it attaches to the liftgate or corner post (unless provisions for supporting the induced side load are made).

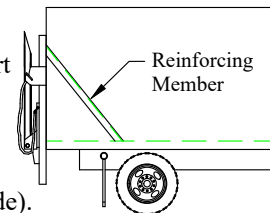

b) If the corner post is not fastened to the side wall or if the corner post cannot carry the required loads, plates can be used to transmit the load to the side walls.

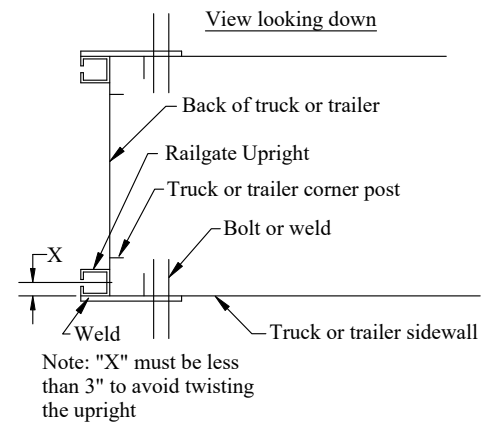
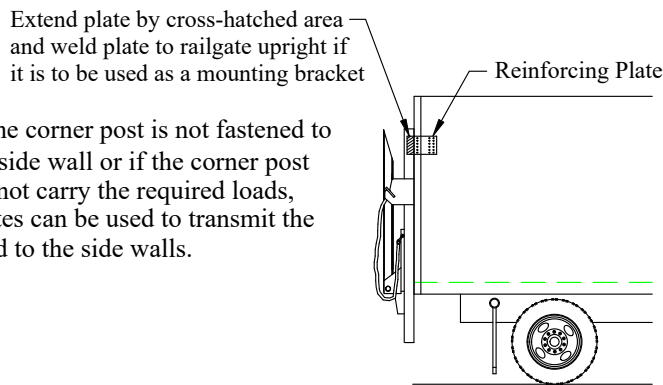

c) If the corner posts cannot carry the required load, and if the railgate is narrower than the truck or trailer by more than 3 inches, an internal support may be necessary to keep the upright from being twisted during railgate operation. This support should be attached through the corner post and fastened to an existing or added bulkhead.

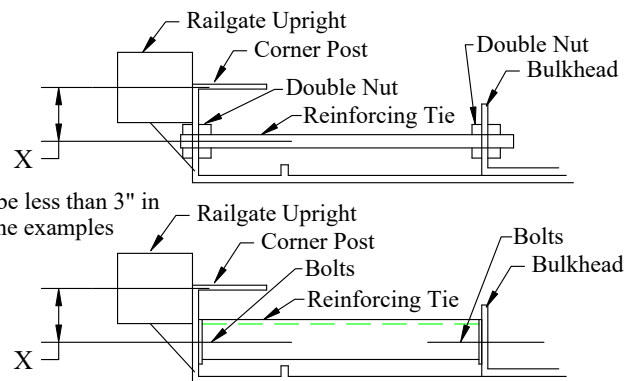

d) If the side wall and/or the door flange can carry the required load but the rear close-out structure is too thin, a backer plate may be needed.

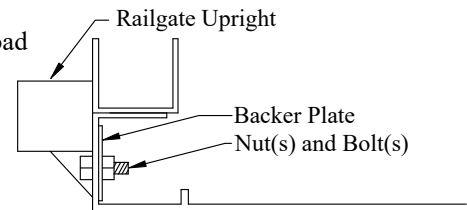

e) If the floor of the truck cannot support the required load, the frame may have to be extended to the truck's rear sill.

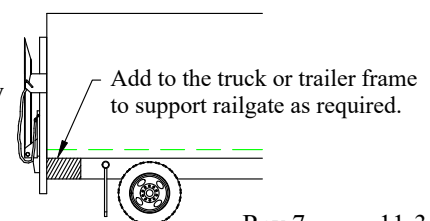

Step 3. Be sure that the rear surface of the corner posts are flush with the rear sill and are vertical. If not, add spacers constructed of flat bar stock to bring these surfaces together.

If structural reinforcement, fittings or truck construction cause the sill to be recessed, add a spacer to the sill for the full width of the Railgate.

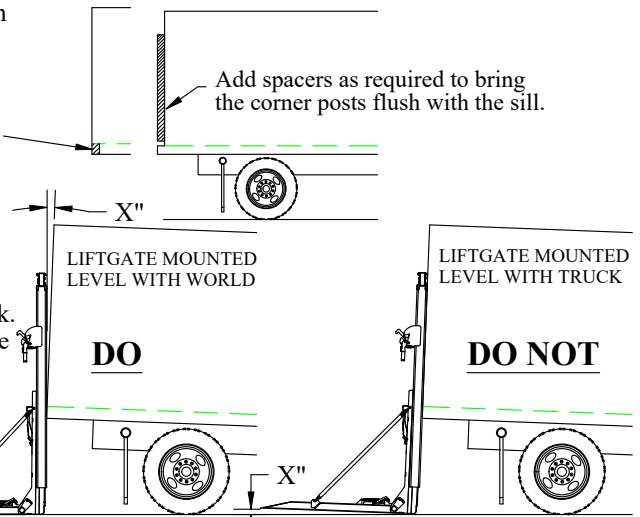

NOTE: Mounting liftgate to the truck

The liftgate must be correctly leveled when mounted to the truck. Level the liftgate to the world, not to the truck. When the liftgate is leveled correctly there could be a small gap between the top of the liftgate and the truck body.

If the liftgate is not correctly leveled the platform taper may not touch the ground when the liftgate is lowered.

Step 4. Use two mounting aids to insure that the liftgate is installed even with bed height.

Step 5. Remove the mainframe box cover by removing the three 5/16" hex nuts.

Packaged inside the mainframe box are the following:

- Operator's manual
- Vent plug
- Wiring Harness
- Warranty sheets
- 200 Amp Manual reset circuit breaker
- Copper lugs
- License plate light, #10x3/4" screws, and #10 lock nuts.
- License plate and 1/4"x1/2" stainless screws
- Padlock with keys

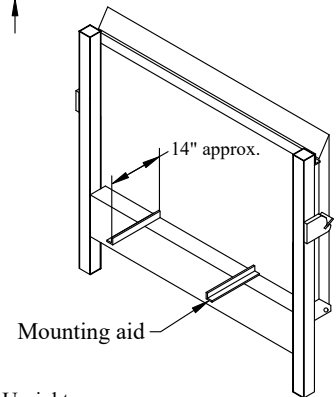

Remove and retain these items along with the box cover and fasteners.

Step 6. If the truck or trailer is aluminum, or welding to the truck is not desirable for another reason, mounting brackets will be necessary. The material these brackets are constructed of and the welds used to attach them must be strong enough to support the loads shown in Step 1. Be sure that the 40" minimum vertical spacing requirement is met. Several possible bracket configurations are shown to the right.

If brackets are to be used, consider attaching them to the upright now. It may be difficult to obtain a strong weld after the railgate is positioned on the truck.

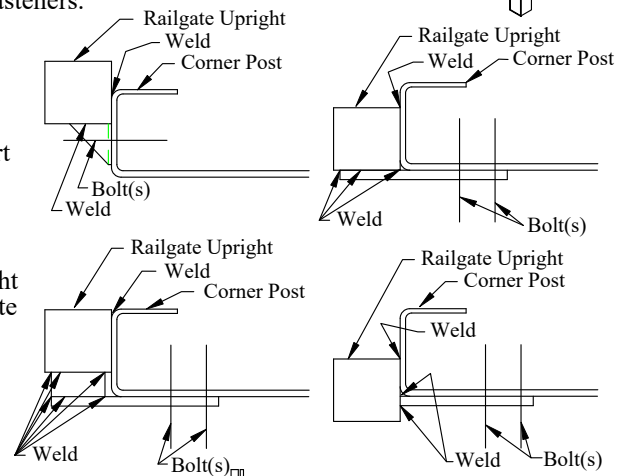

Step 7. Raise the railgate with a fork truck, being sure to pick it up by the angle iron attached to the top of the uprights. Position the railgate onto the truck or trailer with the mounting aids resting on the truck bed inside the vehicle.

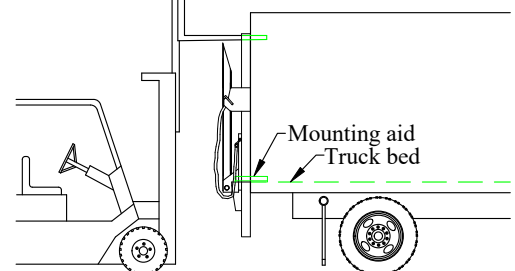

Step 8. Center the railgate on the truck or trailer by measuring the distance between the uprights and the side walls. Position the railgate so the distance on both sides is equal.

Step 9. Tack weld the uprights to the vehicle near the top and bottom of the uprights.

If brackets are being used and are already welded to the uprights, the permanent attaching fasteners can now be installed. Be sure the fasteners are of sufficient size, strength and quality to support the loads illustrated in Step 1.

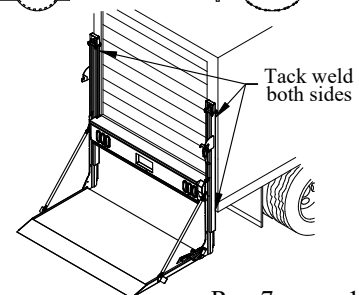

Step 10. Install the circuit breaker on the firewall or fender of the truck or other place in the compartment out of the way of moving parts. Make sure there is easy access for installation of the power cables and so the circuit breaker can be reset.

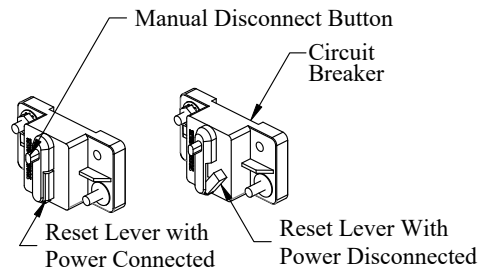

Step 11. Locate the strain relief on the bottom of the liftgate mainframe. Loosen the two screws on the strain relief. Disconnect the positive lead from the terminal on the raise solenoid and the negative cable from the pump and motor common ground. Pull the shipping electrical cable out of the strain relief. Discard the cable.

The liftgate electrical cables are coiled in a separate box that is shipped with the liftgate. Carefully pull the cable ends with the copper lugs installed through the bottom of the strain relief and connect the positive cable to the terminal on the raise solenoid. **Do not overtighten the raise solenoid nuts. Tighten to 35in-lb max.** Connect the negative lead to the common ground on the pump and motor unit. Tighten bolt to 18ft-lb max. Leave approximately two inches of slack inside the liftgate mainframe. Tighten the two screws on the strain relief.

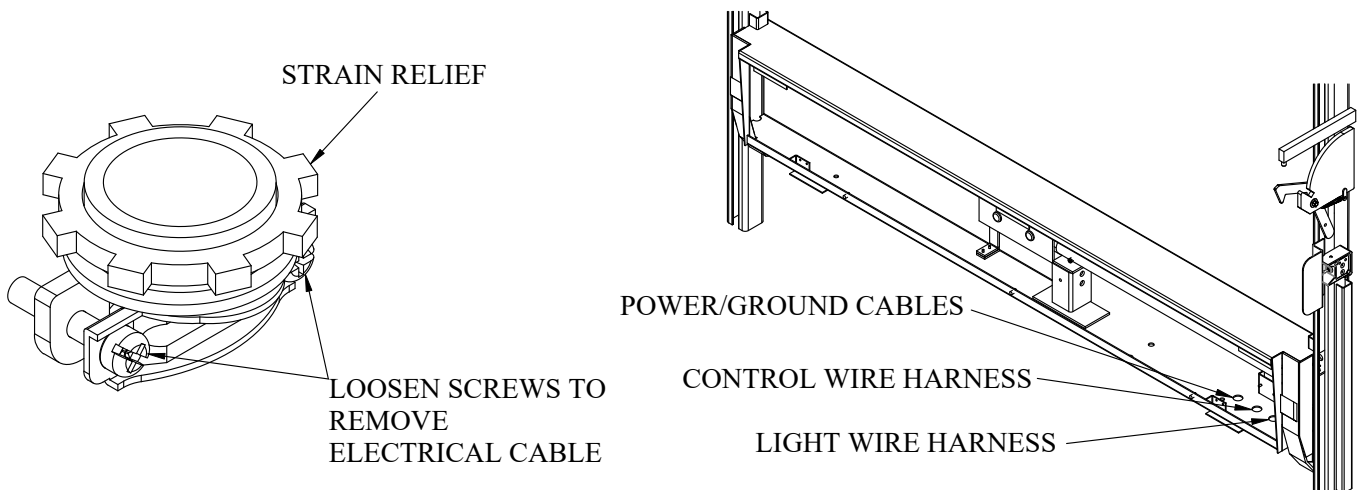

Step 12. Carefully route the cables according to the Tommy Gate Electrical Guidelines along the frame to the battery. Pull the excess cables beyond the battery and separate the positive (+) and negative (-) leads. Cut the positive (+) lead to the length required to reach the auxiliary (AUX) terminal of the circuit breaker. The remaining positive (+) lead needs to be cut at the length required to span the distance from the circuit breaker battery (BAT) terminal to the positive battery terminal.

Cut the negative (-) lead to the length required to reach the negative battery terminal. Install the copper lugs on all required ends and attach them to the circuit breaker and battery as outlined in the Tommy Gate Electrical Guidelines and wiring diagram.

To activate the control, push the hidden "POWER ON" switch (located half way between the Tommy Gate logo and the up decal) once and the amber "POWER ON" LED will illuminate. Now press the hidden button on the control (located under the Tommy Gate logo) twice within one second and the red "LIFTGATE ACTIVATED" LED will illuminate. Once both lights are illuminated you will have power to raise and lower the liftgate.

NOTE: The safety control will automatically shut off if not used for 5 minutes.

IMPORTANT: The pump and motor unit for this lift can require significant electrical power at 12VDC or 24VDC. Be sure you connect the negative(-) cable to the negative(-) terminal of the vehicle battery.

Power Unit Wiring Diagrams (High-Cycle)

!!! PLEASE READ AND FOLLOW ALL DIRECTIONS BEFORE PROCEEDING !!!

IMPORTANT NOTE !!! IF GATES ARE NOT WIRED IN ACCORDANCE WITH THIS DIAGRAM YOUR WARRANTY WILL BE VOID.

IMPORTANT WELDING NOTE !!! DISCONNECT ALL BATTERY CABLES. ALWAYS DISCONNECT THE GROUND CABLE FIRST. ATTACH THE WELDING GROUND TO THE TRUCK RATHER THAN THE LIFTGATE.

NOTE !!! MAIN POWER CABLE ALTERNATE CONSTRUCTION HAS SOLID BLACK AS NEGATIVE (-) AND BLACK WITH RED STRIPE AS POSITIVE(+)

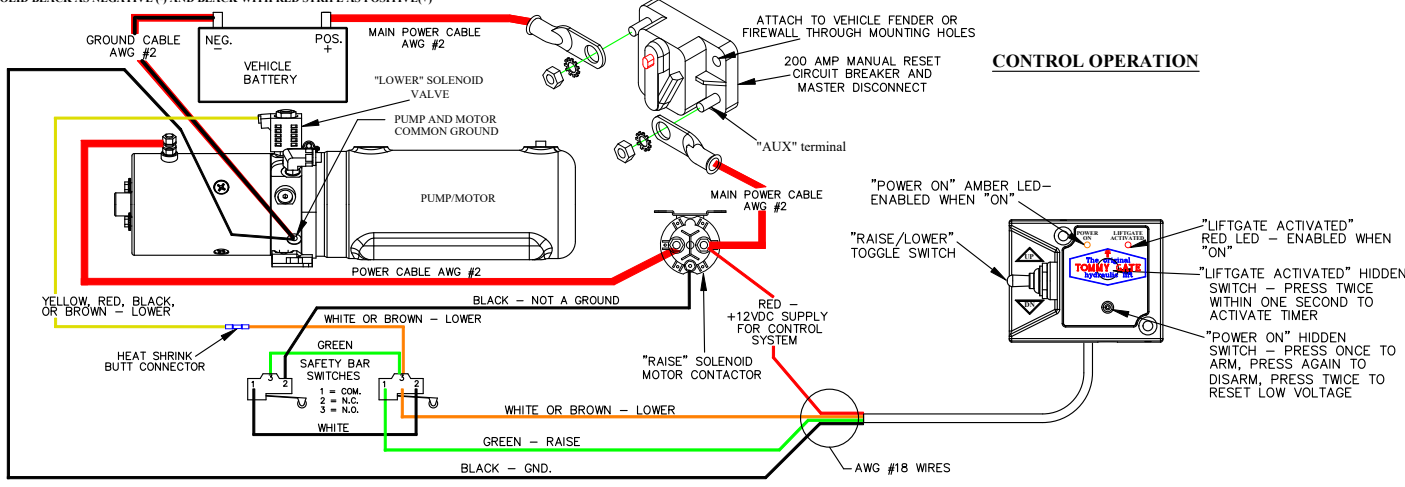

Legend	
	Solenoid contact
	Motor
	Solenoid coil
	Circuit breaker with manual disconnect and reset
	Battery Wire
	Primary Wire
	Grounded through motor chassis
	Elements within are part of the control
	Positive battery terminal
	Negative battery terminal

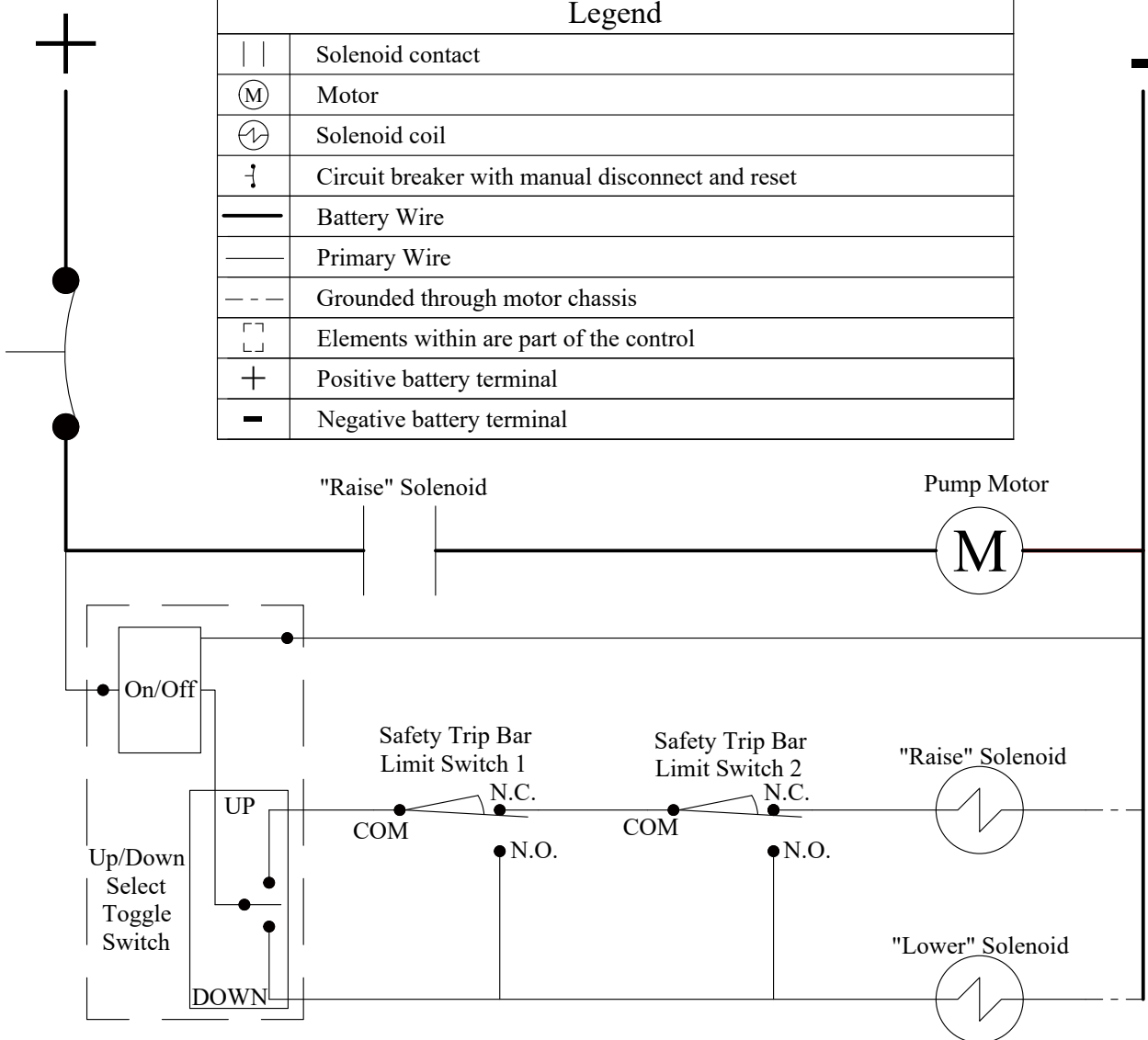

Power Unit Wiring Diagrams (Bifold & GBR)

!!! PLEASE READ AND FOLLOW ALL DIRECTIONS BEFORE PROCEEDING !!!



NOTE !!! IF GATES ARE NOT WIRED IN ACCORDANCE WITH THIS DIAGRAM YOUR WARRANTY WILL BE VOID.



WELDING NOTE !!! DISCONNECT ALL BATTERY CABLES. ALWAYS DISCONNECT THE GROUND CABLE FIRST. ATTACH THE WELDING GROUND TO THE TRUCK RATHER THAN THE LIFTGATE.

NOTE !!! MAIN POWER CABLE ALTERNATE CONSTRUCTION HAS SOLID BLACK AS NEGATIVE (-) AND BLACK WITH RED STRIPE AS POSITIVE(+)

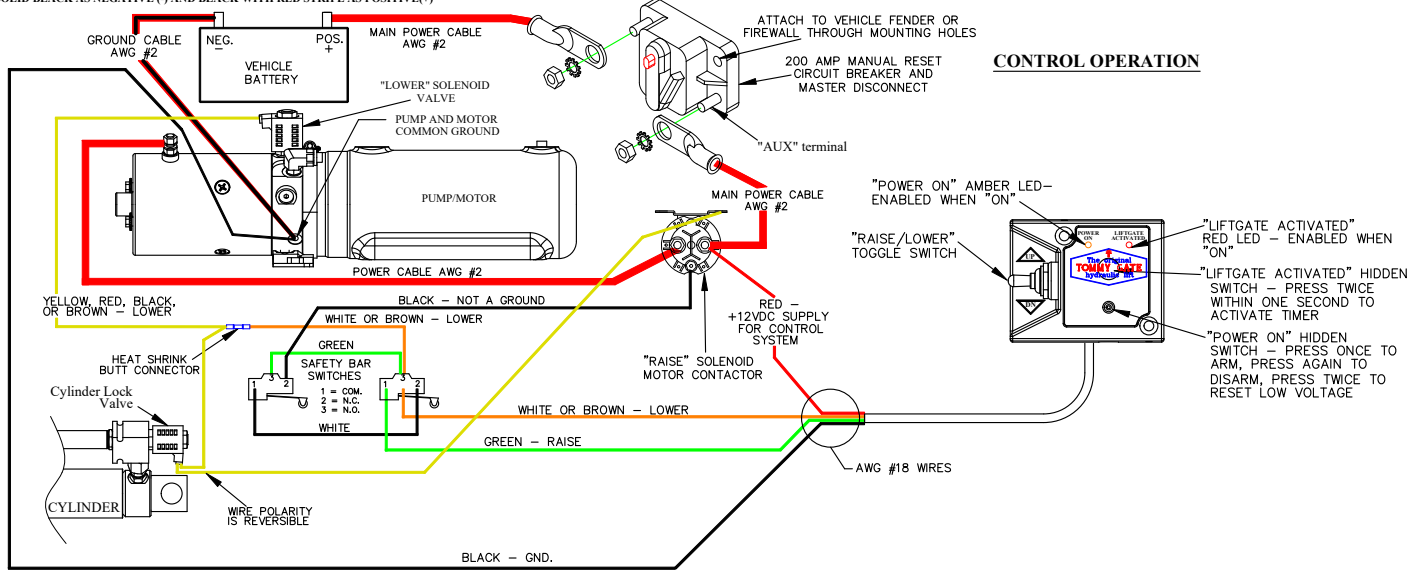

Legend	
	Solenoid contact
	Motor
	Solenoid coil
	Circuit breaker with manual disconnect and reset
	Battery Wire
	Primary Wire
	Grounded through motor chassis
	Elements within are part of the control
	Positive battery terminal
	Negative battery terminal

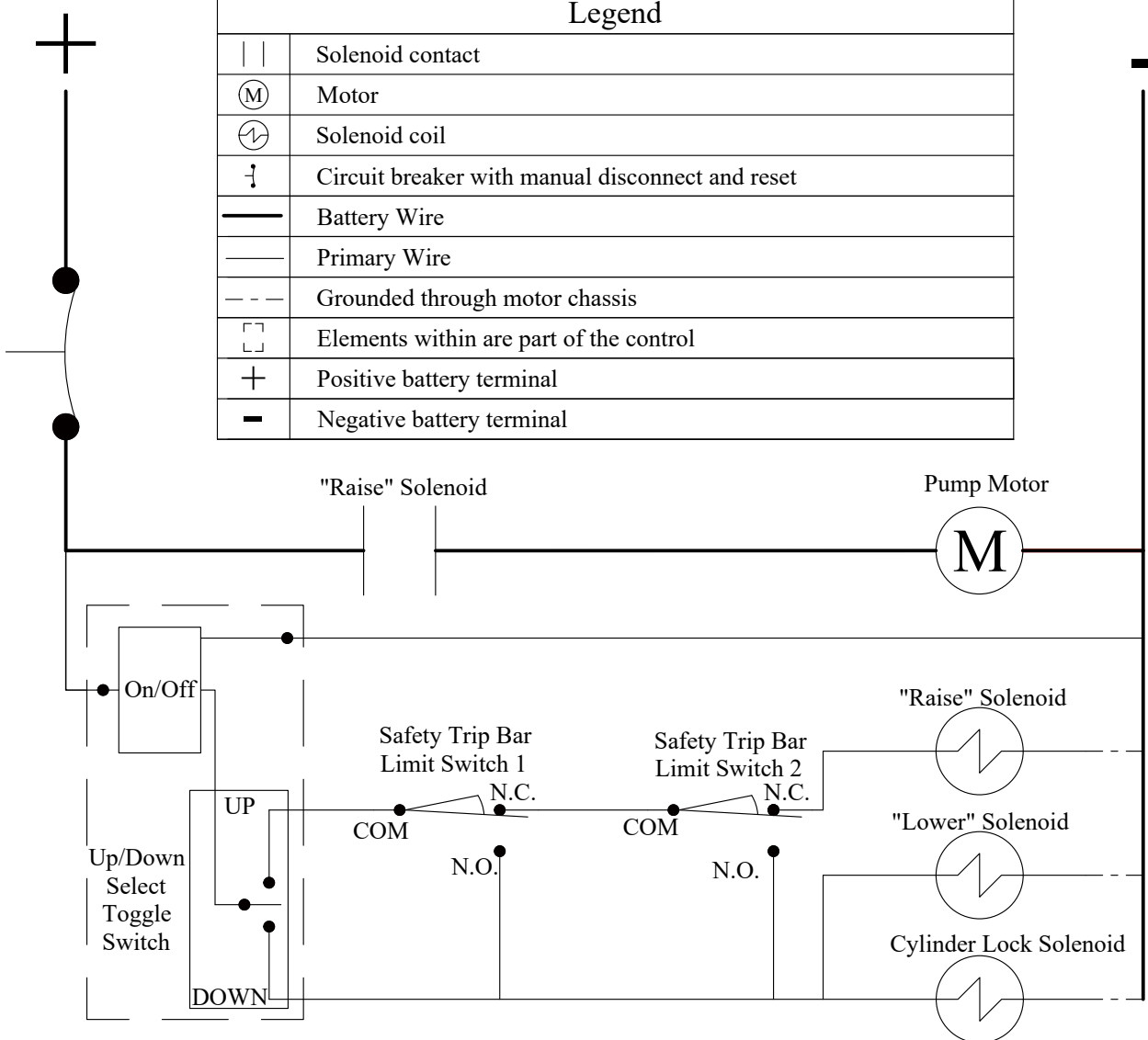

WIRE ROUTING

- (1) When routing wires, avoid heat (above 180°F), abrasion, vibration, metal edges, screws, and trim fasteners. If such routings are not possible, protective devices must be used. If wires must cross a metal edge, the edge should be covered with a protective shield and the wiring fastened within 3 inches on each side of the edge.
- (2) Grommets must be used where wires pass through holes in sheet metal, castings, and / or frame rails. Do not bend wires in a radius smaller than 10 times the wire diameter.
- (3) Routing wires into areas exposed to wheel wash should be avoided. If this cannot be avoided protective shields are required to protect the wires from stones, ice, salt and water damage. Provide a drip loop to prevent moisture from being conducted into switches, relays, circuit breakers, and fuses.
- (4) Wires should be supported every 18 inches with plastic zip ties or rubber-lined clips.
- (5) Wires must be routed to clear moving parts by at least 3 inches unless positively fastened or protected by a conduit. If wiring must be routed between two members where relative motion can occur, the wiring should be secured to each member, with enough wire slack to allow flexing without damage to the wire.
- (6) Maintain at least a 6 inch clearance from exhaust system components. If this is not possible, high temperature insulation and heat shields are required. Existing OEM heat shields, insulation, and wire shielding must be maintained.
- (7) Do not route or attach electrical wires to fuel lines. Route electrical wires at least 1-1/2 inches away from the engine.

BATTERY, WIRE, TERMINALS, AND CONNECTORS

- (1) Wire attachments at the battery must be protected from tension loads so there is no undue strain on the battery terminals. Wires should be routed down rather than horizontally from the terminals with no sharp bends adjacent to the connections.
- (2) Battery power for your Tommy Gate should come directly from the battery through the supplied circuit breaker or fuse. The circuit breaker or fuse should be installed as close to the battery as possible.
- (3) Do not splice battery cables. If splicing is necessary, the most durable splice joint will be bare metal barrel crimped, flow-soldered and covered with adhesive lined heat shrink tubing. Strip the wire ends making sure that individual conductor strands are not damaged. Use only rosin core solder, proper crimping tools, and wire with a gauge at least equivalent to the circuit being lengthened. Do not use electrical tape.
- (4) Battery cable terminals will be bare metal barrel crimped or flow-soldered and covered with adhesive lined heat shrink tubing.
- (5) Use wire connectors with locking features such as positive locking, inertia locking, bolt together, and / or soft mold-over with locking external retainers.

GENERAL

- (1) All frame contact areas must be wire brushed to bare metal, free of paint, dirt, and grease. Frame connections must be made using hardened flat washers under the bolt head and lock nuts. Corrosion preventive grease or compound is to be applied to the terminal area of the frame connection.
- (2) Frame cross members are not recommended as part of the ground return.
- (3) All circuit breakers and fuses should be located in one easily serviceable location with a means provided for identification of circuit function and current rating. Do not put circuit breakers or fuses in the vehicle cab.
- (4) Before welding to the chassis disconnect the battery. Also disconnect the power train, engine, valve, and transmission control modules.
- (5) Do not alter vehicle ignition, starting, and / or charging systems. Do not reroute engine compartment wiring.
- (6) Full copper circuitry and standardized polarity grounds are recommended.
- (7) Never increase the rating of a factory installed fuse or circuit breaker.
- (8) Disconnect the battery negative (ground) wire prior to any vehicle modification.

Following the above guidelines will provide you with years of trouble free service. Failing to incorporate the above guidelines will result in a voided warranty. Non-compliance with the guidelines above may result in a failure of electrical components, shutdown of engines, loss of backup brake systems, and the possibility of fire.

Step 13. Remove the solid plastic plug from the reservoir and replace it with the vent plug provided. The hydraulic system has already been filled with the proper amount of fluid. Do not add any at this time.

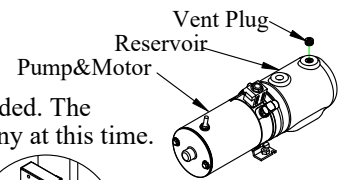

Step 14. Finish attaching the uprights to the truck by placing heavy welds in a location to support the loads referred to in Step 1.

NOTE: A certain amount of draw will occur when welding. To minimize this draw, start with a 1-1/2" weld at the top on the inside of each upright. Then use 1-1/2" stitch welds placed approximately every 18" on the outside of each upright. **Make sure the uprights do not twist and are square with the main frame assembly.**

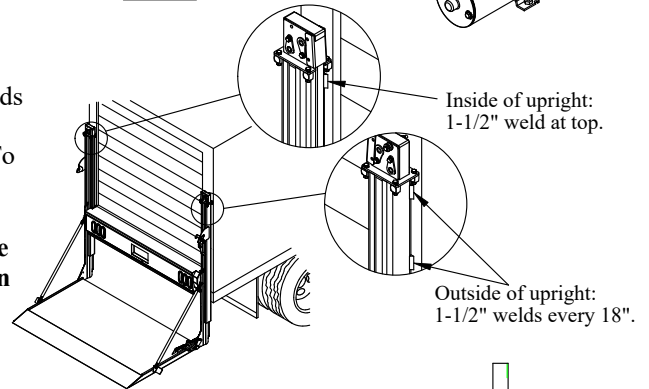

Step 15. Check the clearance between the ground and the bottom of the upright. **Ground clearance under the upright is influenced by truck suspension, box or platform overhang, terrain to be traveled over and maximum load to be hauled.** If the ground clearance under the uprights is insufficient, the bottom of the uprights can be cut off (see warnings below). Do not cut the uprights higher than the bottom of the self close ramp. **After the uprights are cut off, they must have all the sharp edges removed.**

WARNING: The MAXIMUM ground clearance that can be achieved is 21 inches on level ground. If ground clearance of 21 inches is exceeded, roller or liftgate damage may occur.

WARNING: The recommended MINIMUM ground clearance is 15 inches on level ground. Failure to maintain adequate ground clearance could result in gate damage and/or the gate being torn from the truck.

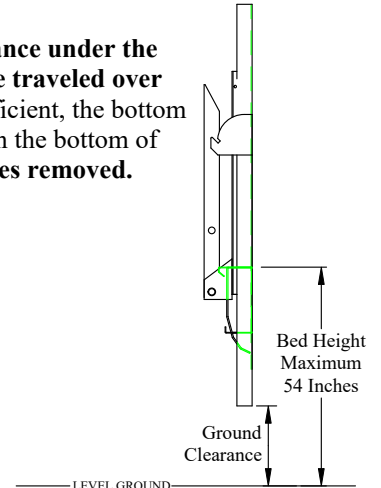

Step 16. If more than 10 inches of the upright extends below the bottom support (**Steel Frame**), a gusset or brace must be used as illustrated.

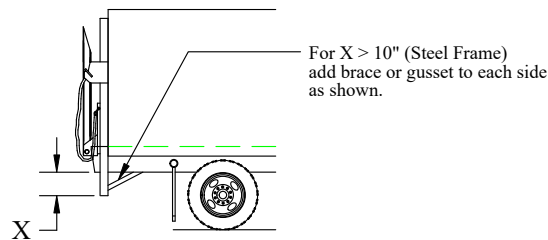

Step 17. Remove the forklift angle iron by removing the bolts.

Step 18. Adjust the platform chains on the gate to equalize the weight distribution between the two chains.

- Park the vehicle on level ground.
- Lower the platform until it is a few inches off the ground.
- Grab the middle of each of the chains to check the tension. (DO NOT stand or put anything on the platform when performing this check.)
- If the tension on both chains appears to be equal, no adjustment is required.
- If one chain has less tension than the other chain perform one of the following:

NOTE: NO PART OF THE CHAIN WILL NEED TO BE DISCONNECTED TO ADJUST THE CHAIN TENSION.

- Tighten the u-bolt lock nuts at the chain adjuster on the loose chain or
 - Loosen the u-bolt lock nuts at the chain adjuster on the tight chain.
- Recheck the tension of the platform chains.
 - If the tension on both chains appears to be equal, proceed to the next step.
 - If further adjustment is needed, repeat the above process (STEP 18e 1-2).

!!WARNING!! VERIFY THAT THREADS OF THE U-BOLT ARE PROTRUDING THROUGH EACH NUT TO AVOID PULLING OF THREADS RESULTING IN FAILURE OF CHAIN TENSION ADJUSTER.

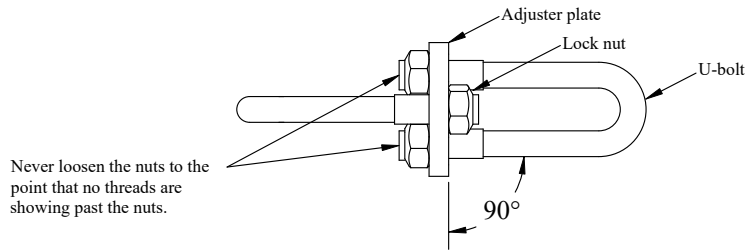
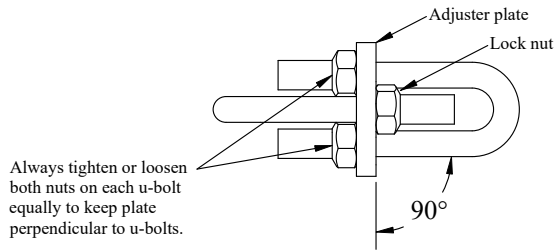

!!WARNING!! ALWAYS ADJUST THE PAIR OF LOCK NUTS ON EACH U-BOLT EQUALLY TO KEEP THE PLATE PERPENDICULAR TO THE U-BOLTS DISTRIBUTING EQUAL TENSION. FAILURE TO DO SO MAY RESULT IN PREMATURE FAILURE OF CHAIN ADJUSTER.

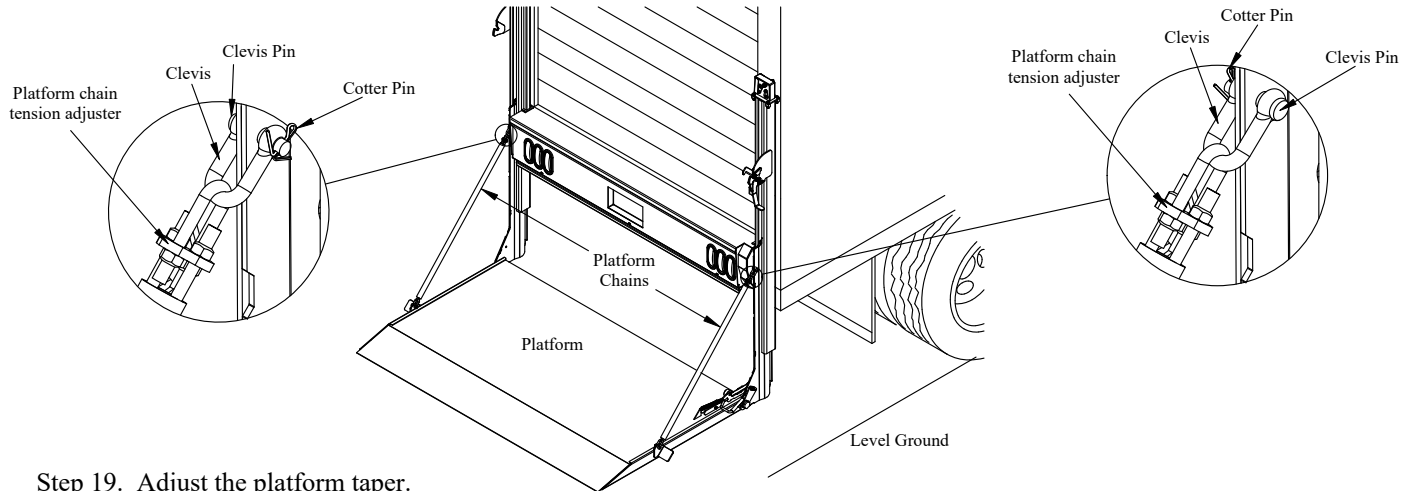

Step 19. Adjust the platform taper.

- To adjust the platform taper lower the platform to the ground and use the same process that was used to adjust the chain tension (STEP 18e 1-2).
- If you loosen the lock nuts, the taper will lower (Adjust each chain equally).
- If you tighten the lock nuts, the taper will rise (Adjust each chain equally).

!!WARNING!! ALWAYS KEEP EQUAL TENSION ON BOTH CHAINS TO AVOID OVERLOADING A SINGLE CHAIN AS THIS WILL CAUSE CHAIN FAILURE.

Step 20. Read the operator's instructions in the owner's manual, then test the operation of the liftgate.

- Check the operation of the timed control for proper lift operation. Be sure the control shuts off automatically after 5 minutes (or 90 seconds for pendant control) of not being used.
- Load the platform with the rated capacity and measure the time necessary to raise the platform. The load should lift through 54 inches of travel in 25-35 seconds or 1.5-2.2 in/sec.
- Move the platform to its highest position.
- Examine the platform for any downward creep.
- With the platform still loaded, time the lowering operation. The load should descend at approximately 10 in/sec.
- If the liftgate does not operate smoothly, lubricate the lifting chain, retest.
- Remove the load from the platform and examine the railgate and truck for any problems.
- If no problems are noticed, lock the gate in the closed position.

Step 21. Install the license plate light in the box cover using the provided screws and lock nuts.

Step 22. Push the license plate nuts into the square holes in the box cover, then use the 1/4"x1/2" stainless steel screws to mount the license plate.

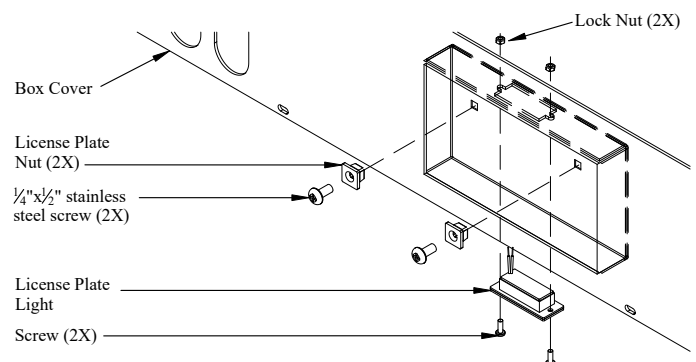

- Step 23 Install the wiring harness for the lights.
- To avoid the risk of an electrical short, disconnect the power cable from the positive side of the battery or manually trip the circuit breaker.
 - Connect the plugs on the harness to the lights on the box cover observing the relationship with the color of wire in the plug to the corresponding light.

NOTE: Make sure that the plug with the yellow "LT/HAZ/TAIL" label is on the driver's side and the plug with the green "RT/HAZ/TAIL" label is on the passenger's side.

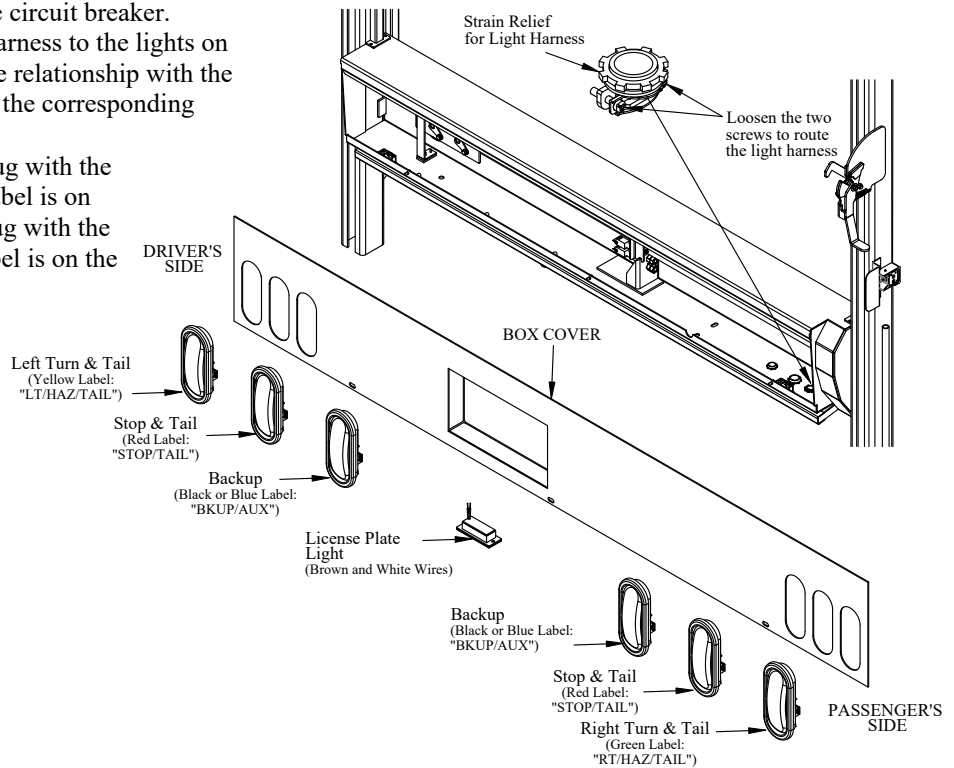

- The brown and white wires that connect to the license plate light must be connected using heat shrink butt connectors.

!!!CAUTION: KEEP ALL WIRES CLEAR OF PINCH POINTS AND MOVING PARTS!!!

- Using the obround holes punched in the box cover and plastic wire ties provided, attach the harness to the back of the box cover as shown. If needed, coil the harness in the position shown to keep the harness tight.

NOTE: If the harness is not routed in accordance with the pictures, the harness will be severed by moving parts.

- Pull the harness end to be attached to the vehicle down through the light harness strain relief in the bottom of the liftgate mainframe.
- Connect the harness to the vehicle's wiring.
- Install the license plate light.
- Check the lights for proper operation.
- Reinstall the box cover.
- Verify proper operation of lights.

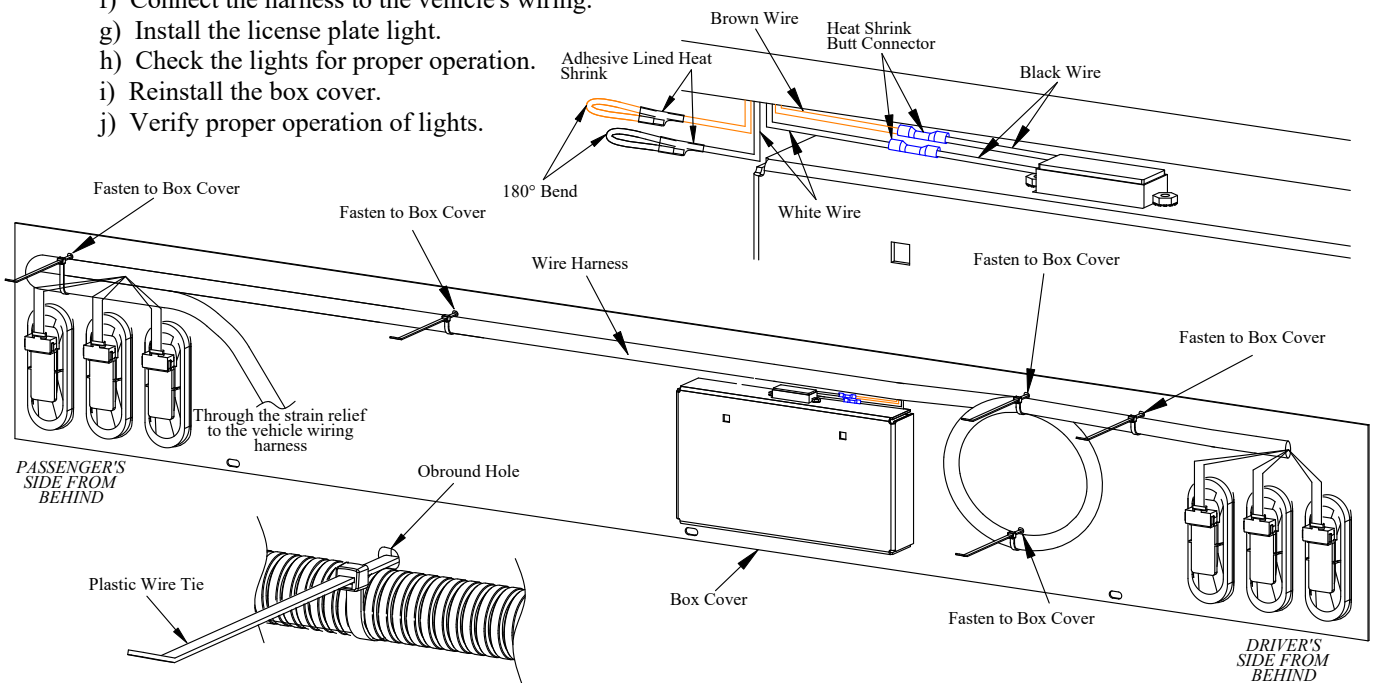

Light Circuit Diagrams

ELECTRICAL GUIDELINES:

- (1) THE INSTALLER IS RESPONSIBLE FOR USING PROPER TECHNIQUES WHEN INTERFACING WITH VEHICLE ELECTRICAL SYSTEMS.
- (2) FAILURE TO COMPLY WITH THE OEM GUIDELINES COULD RESULT IN UNSAFE VEHICLE OPERATION, FAILURE OF OEM WIRING, OR VEHICLE FIRE.
- (3) NEVER REPLACE OEM FUSES AND/OR CIRCUIT BREAKERS WITH FUSES OR CIRCUIT BREAKERS WITH A HIGHER RATING.
- (4) THE TOTAL CIRCUIT CURRENT DRAW SHOULD NOT EXCEED 80% OF THE OEM CIRCUIT FUSE OR CIRCUIT BREAKER.
- (5) USE BODY BUILDER JUNCTION BLOCKS, CUSTOMER ACCESS CIRCUITS & CONNECTORS RATHER THAN EXTENDING OEM CIRCUITS.
- (6) INCORPORATE RELAYS INSTEAD OF SPLICING INTO THE OEM ELECTRICAL SYSTEM.
- (7) USE APPROPRIATE GAUGE WIRE FOR EXTENDING CIRCUITS. THE WIRE GAUGE SHOULD BE CAPABLE OF SUPPORTING THE MAXIMUM LOAD TO WHICH THE ADDED CIRCUIT WILL BE EXPOSED.
- (8) OEM ELECTRICAL WIRE COLOR CODING SHOULD BE MAINTAINED WHEN EXTENDING CIRCUITS.
- (9) WHEN ADDING CIRCUITS, ALWAYS INCORPORATE FUSE OR CIRCUIT BREAKER PROTECTION.

NOTE: ⊗ SYMBOL INDICATES USAGE OF HEAT SHRINK BUTT CONNECTOR
 X INDICATES WIRE END IS SEALED AWAY AND NOT USED.

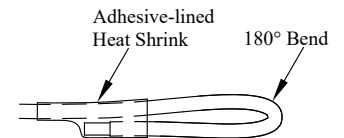

COMBINED STOP/TURN FUNCTION

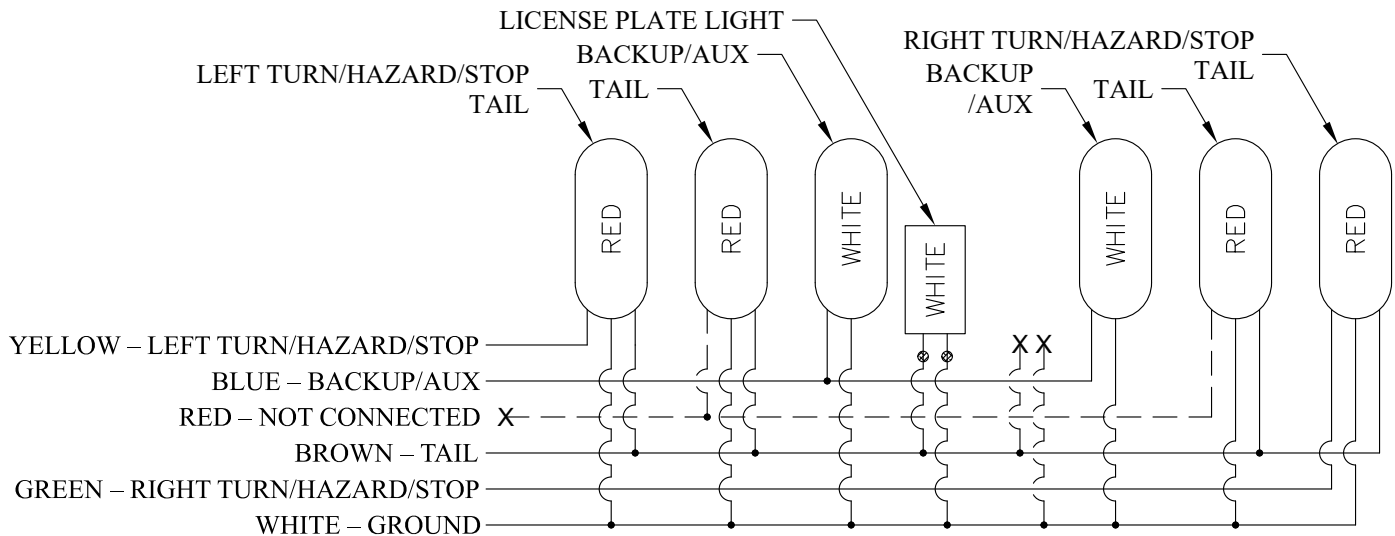

SEPARATED STOP/TURN FUNCTION

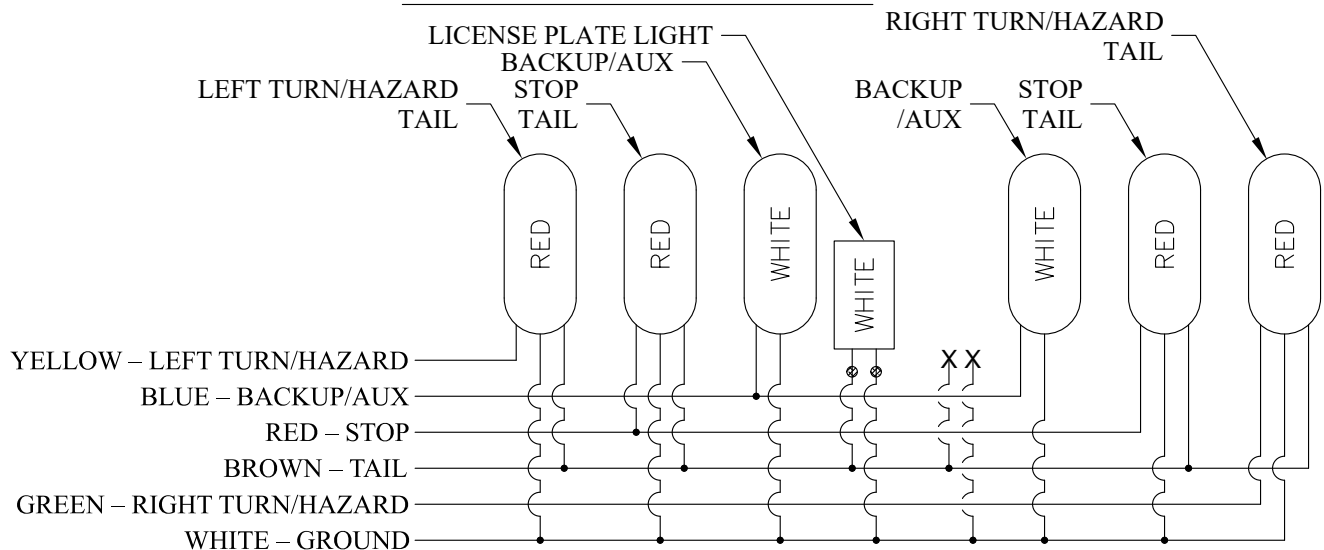

Step 24. Your Tommy Gate has been primed with a gray polyurethane and painted with a black semi-gloss polyurethane top coat to protect it from the environment. No additional paint is required unless shipping or installation damage or outdoor storage exposure has deteriorated the Tommy Gate paint. **Tommy Gate will not be responsible for shipping or installation damage or outdoor storage exposure that has marred or otherwise deteriorated the Tommy Gate paint.**

If you need to refinish the liftgate, you should do the following:

Remove any dirt, oil, grease, salt or other contamination by washing with a mild detergent solution. Rinse thoroughly with fresh water and allow to dry. Lightly scuff the Tommy Gate topcoat.

If prolonged exposure, shipping, or other installation damage has deteriorated the Tommy Gate paint, it will be necessary to sand and spot prime the area(s) prior to finish coating. Mask off all safety decals before painting. After proper cleaning and surface preparation, apply desired finish coat per paint manufacturer's recommendations.

Step 25. Remove the masking from the safety decals. **Make sure all decals are clean and legible.** Additional decals are available from the factory, if needed.

Step 26. Place Maintenance and Operator's manual in the Truck.

Step 27. Always install the latch padlock and deactivate the control when not in use.

