

Transit CVL Rear Sensor Relocation Instructions

These instructions will aid you in relocating OEM rear sensors on a Ford Transit equipped with a Tommy Gate Cantilever (CVL) liftgate.

Preparing for Installation

1. **Verify** sensor kit (Figure 1 and Table 1).

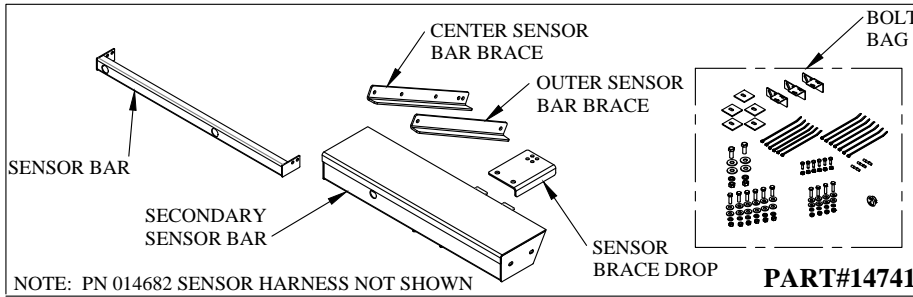

Figure 1: Part identification.

Table 1: Parts list.

QTY.	PART NO.	DESCRIPTION
1	14751	TRANSIT SENSOR BAR
1	14746	TRANSIT SECONDARY SENSOR BAR
1	14755	CENTER SENSOR BAR BRACE
1	14752	OUTER SENSOR BAR BRACE
1	14682	TRANSIT SENSOR HARNESS EXTENSION
1	14774	TRANSIT SENSOR BAR BOLT BAG
1	14756	SENSOR BRACE DROP

2. **Unplug** and **Remove** wire harness for sensors #1 and #2 from vehicle harness in bumper (Figure 2).

Note: This portion of the wiring harness will not be reused.

3. **Remove** and **Save** sensors #1, #2, and #3 from vehicle harness (Figure 2).

Note: Sensor #4 remains in factory location.

4. **Insert** hole plug into empty sensor #3 hole on driver side.

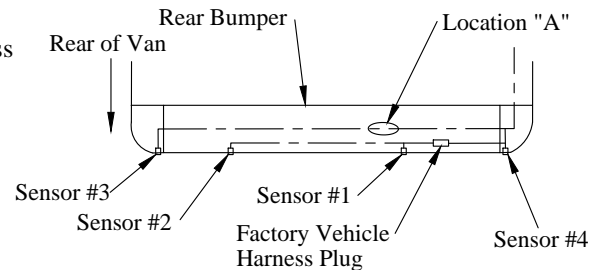

Figure 2: Factory vehicle wire harness.

Installing the Sensor Bar Kit

1. **Bolt** sensor bar to bottom of platform pivot bar using provided 5/16" bolts, washers, lock washers, and nuts (Figure 4).
The washers may be used as a shim between the two plates.
Note: If bolt locations are not available, **Weld** sensor bar to platform pivot bar.
2. **Bolt** the sensor brace drop to the mounting frame using provided 1/2" bolts, washers, lock washers, and nuts (Figure 3).
3. **Bolt** the mounting brackets of the secondary sensor bar to the under side of the van using mounting hardware from the bumper and provided aluminum spacers as needed (Figure 3).
Note: Aluminum spacers are used to shim secondary sensor cover flush with bumper cover plate (Figure 4).
4. **Bolt** the outer sensor bar brace between the liftgate side plate and secondary sensor bar using provided 3/8" bolts, washers, lock washers, and nuts (Figure 3).
5. **Bolt** the center sensor bar brace between the sensor brace drop and secondary sensor bar using provided 3/8" bolts, washers, lock washers, and nuts (Figure 3). Make sure secondary sensor bar is level.
6. **Bolt** the secondary sensor bar to the passenger bumper cover plate with provided 3/8" bolts, washers, lock washers, and nuts (Figure 4). **Drill** holes in bumper cover plate if needed.

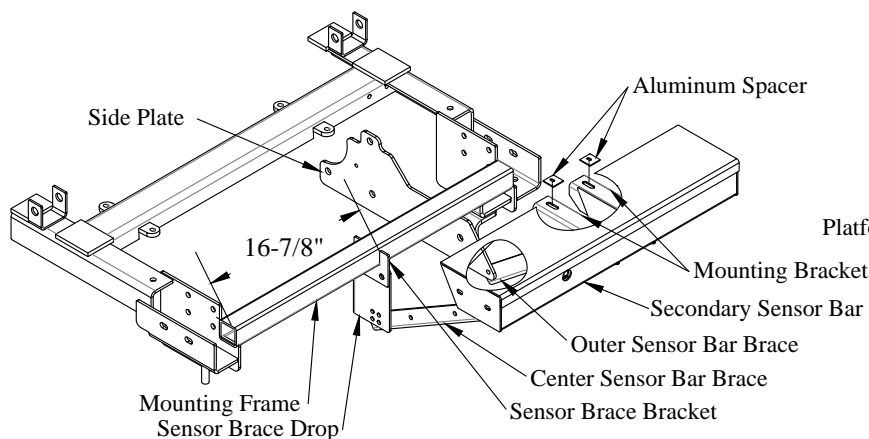

Figure 3: Secondary sensor bar.

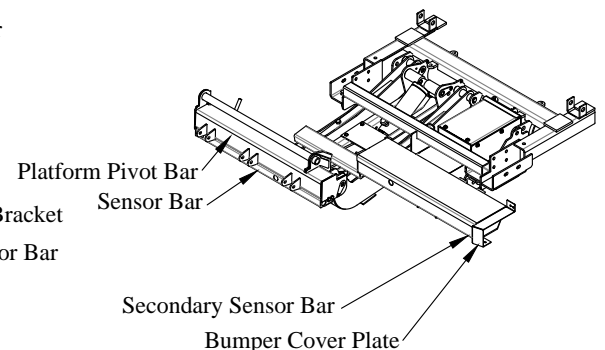

Figure 4: Sensor Bar Kit.

Transit CVL Rear Sensor Relocation Instructions

Installing New Wire Harness

1. **Feed** the vehicle plug end of the new sensor harness through the secondary sensor bar mounting brackets. Start at the van center and stop at the factory vehicle harness plug (Figures 2 and 7).
2. **Plug** new sensor harness into vehicle wire harness (Figure 5).
3. **Route** new sensor wire harness along the center sensor bar brace (Figure 8).
4. **Route** new sensor wire harness over the top and down the inside of the passenger side lift arm, following limit switch wire harness (Figure 8).
5. **Route** new sensor wire harness into the back of the sensor bar (Figure 8).
6. **Follow** vehicle harness from sensor #3 until you reach location "A", near sensor #1 and **Cut** the harness. Leave enough length to complete the next step (Figure 2).
7. **Splice** sensor harness into vehicle harness at location "A", matching wire color (Figure 5).
8. **Plug** sensors into new sensor harness (Figure 5).
9. **Position** sensors into brackets and fix in position using zip ties. Be sure connector hangs over edge of bracket, allowing the back of the sensor to be flat against the bracket (Figure 6 and Figure 7).
10. **Install** sensor brackets in sensor bar and secondary sensor bar.
11. **Adjust** sensor brackets so sensors are positioned as follows (Figure 8).
 Sensor #1 is at about a 15° angle to the secondary sensor bar, and partially protruding.
 Sensor #2 is square with the sensor bar, and flush or slightly protruding.
 Sensor #3 is at about a 15° angle to the sensor bar, and can be partially recessed in the bar.
12. **Secure** new sensor wire harness with zip ties.
13. **Do Not Install** sensor cover on sensor bar, even if one is provided. It may interfere with the function of the sensors.
14. **Test** rear sensors for proper operation.

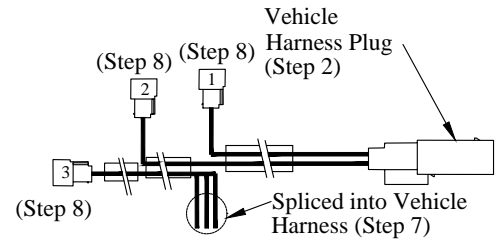

Figure 5: New sensor harness.

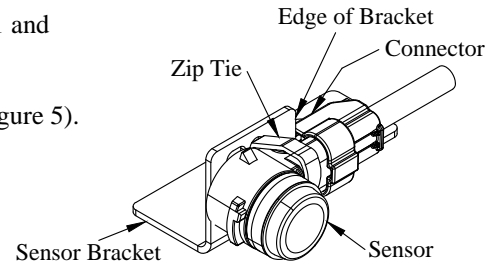

Figure 6: Orientation of sensor in bracket.

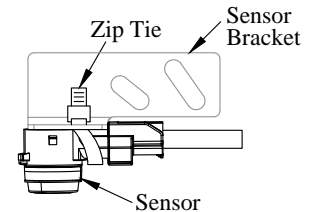

Figure 7: Top view of sensor in bracket.

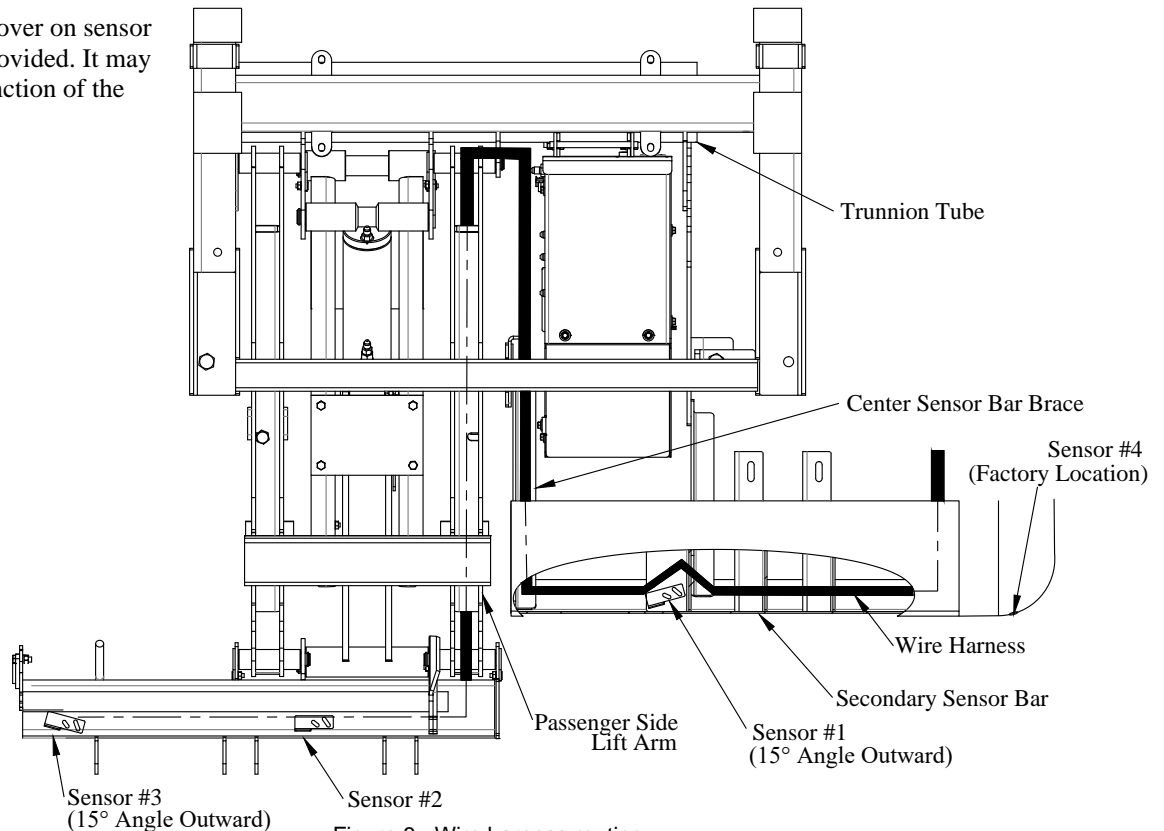

Figure 8: Wire harness routing.