

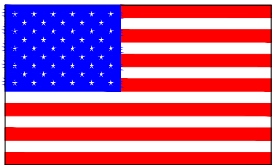

Woodbine, Iowa



Made in America

OWNER'S / OPERATOR'S MANUAL

- Safety Information
- Warranty Information
- Operator's Instructions
- Maintenance Instructions
- Parts List

CANTILEVER SERIES

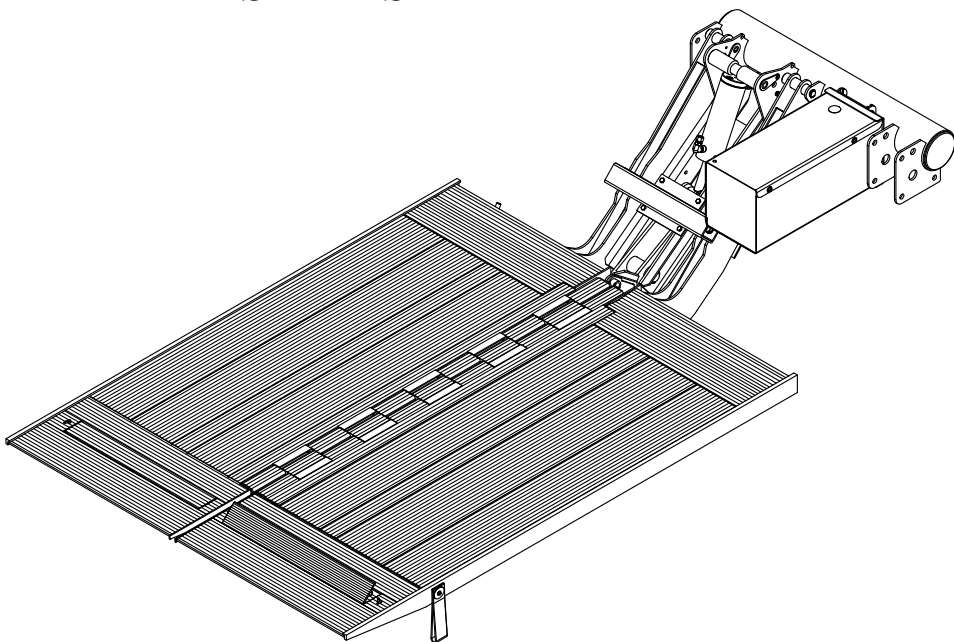

Before installing or using this Liftgate, please observe the Vehicle Loading Limitations. These loading limitations are outlined in the Vehicle Owner's Manual and the Safety Compliance Certification Label located on the driver's door pillar.



PLEASE KEEP IN VEHICLE



TABLE OF CONTENTS

| <u>Introduction</u> | <u>Page#</u> | |
|---|--------------|---------|
| To the Owner\Operator | 3 | |
| <u>Safety Decals</u> | | |
| Location and Descriptions. | 4 - 7 | |
| Decal Replacement. | 7 | |
| <u>Operator's Instructions</u> | | |
| Cantilever Series Terms and Method of Operation | 8 | |
| Operator's Instructions | 9 & 10 | |
| Platform Adjustment | 11 & 12 | |
| Emergency Chain-up Feature. | 13 | |
| <u>Electrical Wiring Diagrams</u> | | |
| Complete Wire Diagram | 14 | |
| Ladder Logic/Wiring Diagram | 15 | |
| Pendant Plug Wiring Diagram | 16 | |
| <u>Maintenance and Service</u> | | 17 |
| <u>Troubleshooting</u> | | 18 & 19 |
| <u>Warranty</u> | | |
| Standard Warranty. | 20 | |
| Warranty Claims Handling Procedure. | 20 & 21 | |
| <u>Repair Parts List</u> | | |
| Repair Parts Drawing. | 22 & 23 | |
| Repair Parts List. | 24 | |
| <u>Service Records</u> | | 27 |
| <u>Contact Information</u> | | 28 |

TO THE OWNER\OPERATOR

Read this manual completely before using your gate. Operate and maintain your gate safely as outlined in this manual. Be sure you read and understand all operating, safety, maintenance and service information. Should you need repair or service information, contact Tommy Gate or an authorized distributor for assistance.



This is the safety alert symbol. It is used to alert you to potential personal injury hazards. Obey all safety messages that follow this symbol to avoid possible injury or death.



DANGER indicates an imminently hazardous situation which, if not avoided, will result in death or serious injury.



WARNING indicates a potentially hazardous situation which, if not avoided, could result in death or serious injury.



CAUTION indicates a potentially hazardous situation which, if not avoided, may result in minor or moderate injury.



CAUTION indicates a potentially hazardous situation which, if not avoided, may result in property damage.

Safety is a primary concern in the design and manufacture of our products. Unfortunately, our efforts to provide safe equipment can be wiped out by a single careless act of an operator.

Accident prevention and safety are dependent upon the awareness, concern, prudence and proper training of the personnel who operate, transport, maintain and store this equipment. It is your responsibility to use good judgment in the operation of this equipment.

It has been said that **"the best safety device is an informed, careful operator."** We ask you to be that kind of operator.



DECAL LOCATIONS AND DESCRIPTIONS

Locate and read all decals prior to operating gate
REPLACE IF MISSING OR NOT READABLE

TOMMY GATE®

| | |
|--|---|
| <p>DO'S</p> <ul style="list-style-type: none"> * DO CENTER YOUR LOAD ON PLATFORM. * DO CLOSE AND LOCK LIFT IN CLOSED POSITION WHEN NOT IN USE OR UNATTENDED. * DO STAND TO THE SIDE OF LIFTGATE WHILE IT IS IN OPERATION. * DO READ MAINTENANCE AND SERVICE INFORMATION. * DO READ OPERATOR'S INSTRUCTIONS. * DO FREQUENTLY CHECK CABLES, CHAINS, AND OTHER COMPONENTS FOR WEAR OR DAMAGE AND REPAIR AS NECESSARY WITH PARTS PROVIDED BY THE ORIGINAL EQUIPMENT MANUFACTURER. * DO CHECK ALL SAFETY DEVICES FOR PROPER OPERATION . | <p>DO NOT'S</p> <ul style="list-style-type: none"> * DO NOT RIDE OR PERMIT ANYONE TO RIDE ON LIFT. THE LIFT IS NOT A PERSONNEL OR WHEELCHAIR LIFT. * DO NOT MAKE ANY MODIFICATIONS TO THE LIFT OR ITS SAFETY FEATURES. * DO NOT ALLOW USE OF LIFT BY A PERSON WHO HAS NOT HAD PROPER TRAINING IN ITS OPERATION. * DO NOT TRY TO LIFT OR LOWER MORE THAN THE RATED CAPACITY OF THE LIFT. * DO NOT ADD TO OR REMOVE PARTS OF LIFT AS IT WILL VOID YOUR WARRANTY. * DO NOT MOVE VEHICLE UNLESS GATE IS IN LATCHED POSITION. * DO NOT SHOW CHILDREN OR UNAUTHORIZED PERSONNEL HOW TO OPERATE LIFT. * DO NOT LEAVE PLATFORM OPEN, OR UNLATCHED WHEN LIFT IS NOT IN USE OR UNATTENDED. NEVER LEAVE PLATFORM DOWN TO BE USED AS A STEP. |
|--|---|

ALL REPAIRS OR REINSTALLATIONS OF TOMMY GATE LIFTS SHOULD BE PERFORMED BY AN AUTHORIZED DISTRIBUTOR THAT IS FAMILIAR WITH ITS OPERATION AND SAFETY FEATURES. ALL REPLACEMENT PARTS MUST BE OF ORIGINAL QUALITY, AND ALL SAFETY AND OPERATIONAL DECALS MUST BE ATTACHED AND LEGIBLE

9561

Decal No. 1

Place in cab in a highly visible area.

WARNING

Read operator's manual before operating equipment.

Do not modify lift or its safety features.

Use only Tommy Gate service parts installed by an authorized distributor.

If additional assistance is needed, call Tommy Gate at 712-847-8000.

Do not exceed the rated lift capacity-

9524

Decal No. 2

Located on the side of the pendant control.

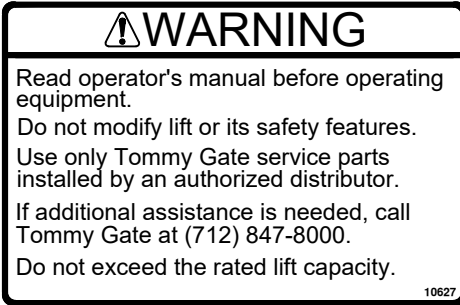

Decal No. 3
Two decals.

Located on the left-hand side of platform. Position up when platform is unfolded.
Located on the back of the platform, when platform is folded, positioned up.



Decal No. 4
Two decals.

Located on the left-hand side of platform. Position up when platform is unfolded.
Located on the back of the platform, when platform is folded, positioned up.

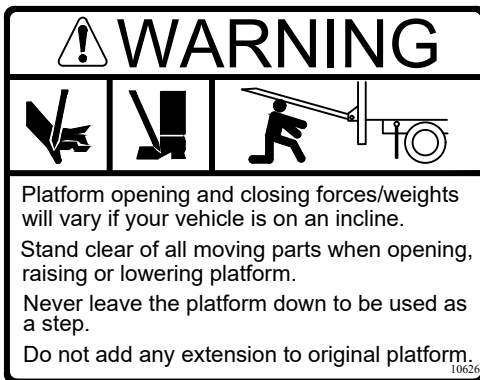

Decal No. 5

Located on the back of the platform, when platform is folded, positioned up.

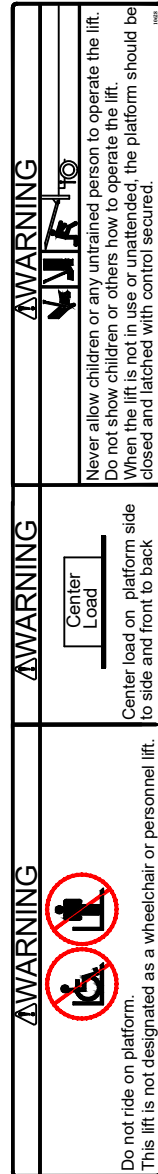

Decal No. 6
Two decals.

Located on the left-hand side of platform. Position up when platform is unfolded.
Located on the back of the platform, when platform is folded, positioned up.

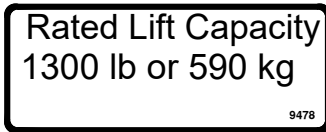

Decal No. 7

Two decals.

Located on the left-hand side of platform. Positioned up when platform is unfolded.

Located on the side of the pendant control

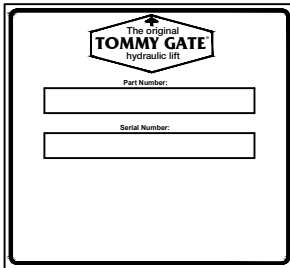

Decal No. 8

Two decals.

Located on the inside of the driver side main tube.

Located on the outside of the passenger side tension arm.

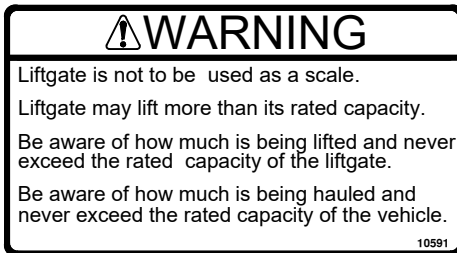

Decal No. 9

Two decals.

Located on the left-hand side of platform. Position up when platform is unfolded.

Located on the back of the platform, when platform is folded, positioned up.

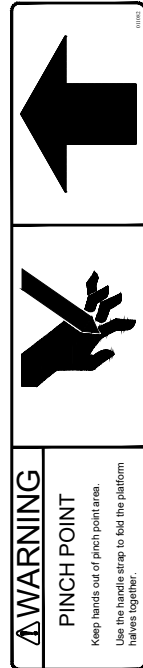

Decal No. 10

Two decals.

Located on the left-hand side of each platform.
Position up when platform is unfolded.
(Arrows face each other when platform is folded)

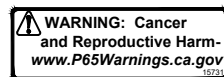

Decal No. 11

Located on the side of the pendant control.

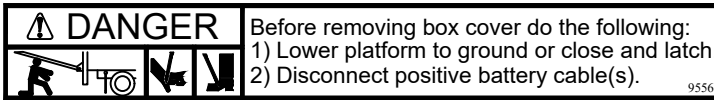

Decal No. 12
Located on rear out side of power unit case.

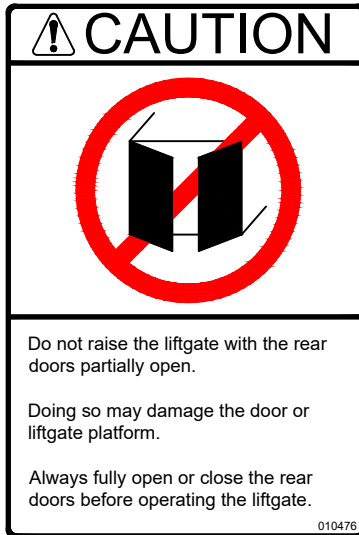

Decal No. 13
Located on the exterior bottom right corner of the driver side rear door.



Decal No. 14
Located on the top of the license plate holder.

DECAL REPLACEMENT

NOTE: When ordering Decals, please have Decal Numbers available.

To replace decal, clear area of grease and dirt with non-flammable solvent and soap and water. Allow to dry. To apply decal, peel off 1/2 of back. Hold decal squarely and apply to cleaned surface. Peel off remaining back and smooth in place. Gently rub decal with a damp rag or sponge to smooth out bubbles. (The decal has a pressure-sensitive adhesive on the back.)

If the liftgate **is** going to be painted, you need to mask the decals before painting. Remove the mask **after** painting so the decals can be read clearly.

CANTILEVER SERIES

TERMS AND METHOD OF OPERATION

Your Tommy Gate operates off your vehicle battery. The vehicle battery powers a motor coupled to a hydraulic pump. Placing the toggle switch into the raise position will direct the pump flow to retract the cylinder attached to the lift arm and the platform will raise. A check valve blocks return flow from the cylinders to the pump and a pressure relief valve prevents the gate from being overloaded.

!Warning: Liftgate is not to be used as a scale. Liftgate may lift more than its rated capacity. Be aware of how much is being lifted and never exceed the rated capacity of the liftgate. Be aware of how much is being hauled and never exceed the rated capacity of the vehicle.

Placing the toggle switch into the lower position will direct the pump flow to extend the cylinder attached to the lift arm and the platform will lower. Once the lower arm contacts the ground the cylinder will continue to extend and will tilt the platform's taper end down.

Tommy Gate's control includes a low voltage warning feature. When the control is armed with 7 volts or less present at the power unit, the amber "POWER ON" LED will blink. This warns the operator of the low voltage condition, but will not disable the liftgate. The gate may still raise or lower, depending on how low the voltage is. Correct this condition as soon as possible.

Caution: Continuing to operate the the liftgate in the low voltage condition may result in failure of electrical components in the power unit.

The low voltage condition may be caused by a weak battery, loose or corroded connections, improper ground, or bad electrical cables. This condition may be corrected by just starting the vehicle or replacing the battery.

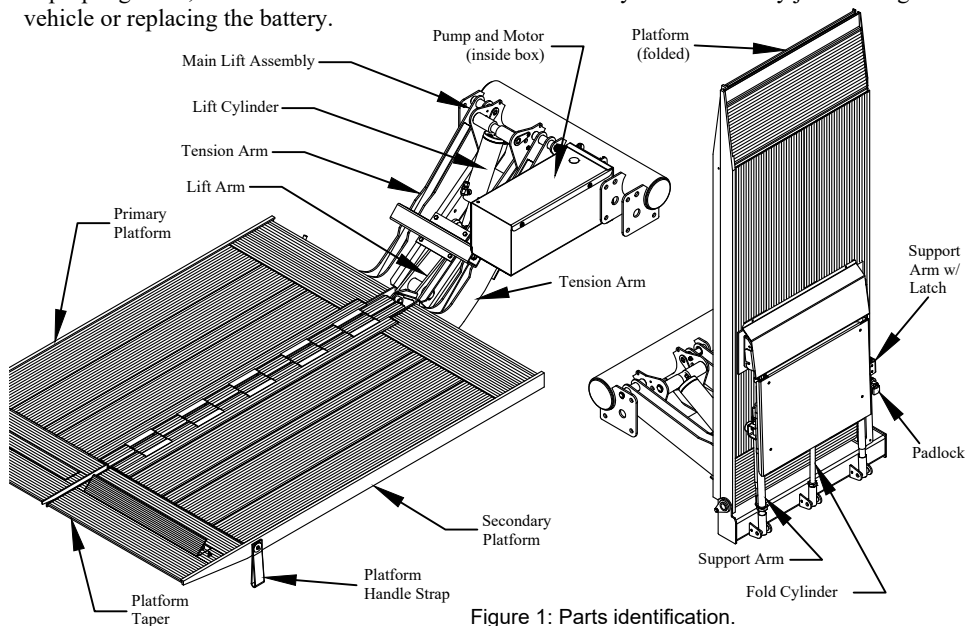

Figure 1: Parts identification.

OPERATOR'S INSTRUCTIONS

!Caution:

Never leave the truck with the platform on the ground, partially raised, or open. Never show children or unauthorized personnel how to operate the gate.

To prevent children or unauthorized personnel from operating the lift, be sure the gate is in the stored position and the padlock is installed. Make sure the control is deactivated before leaving the truck unattended.

!Warning: The Tommy Gate is an industrial product for material handling only and is not to be used as a personnel or wheelchair lift. Do not ride on the platform and always stand clear of the platform when opening, raising, or lowering.

- Step 1. Unlock padlock and remove pin from support arm. Open the rear van door and locate the FOLD/UNFOLD toggle switch (mounted on the van pillar) and the pendant control.
- Step 2. Be sure to stand clear of the platform and all moving parts when using the lift.
- Step 3. To turn the control power on, press the "POWER ON" hidden switch once, marked with black rings or circles (located between the Tommy Gate logo and the toggle switch). You should see the amber LED "POWER ON" light when the control is armed. To disarm the control, press the "POWER ON" hidden switch again.
- Step 4. To activate the control, press the " LIFTGATE ACTIVATED" hidden switch twice within one second (located under the Tommy Gate logo). You should see the red "LIFTGATE ACTIVATED" light when the control is activated.

Note: After you have activated the control, you have approximately 90 seconds to use the gate. If the gate is not used for approximately 90 seconds, the "LIFTGATE ACTIVATED" timer deactivates the control. If the gate is used during the 90 seconds, the "LIFTGATE ACTIVATED" timer automatically resets for an additional 90 seconds. To reactivate the timer, press the "LIFTGATE ACTIVATED" hidden button twice within one second.

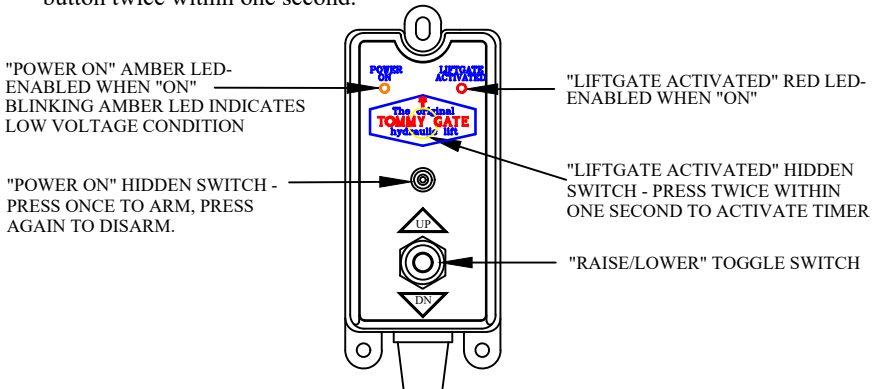

Figure 2: Control.
Page 9 of 28



OPERATOR'S INSTRUCTIONS

Step 5. To unfold the platform, stand to the side clear of the platform and all moving parts, then push the pendant toggle switch down while pushing either up or down on the FOLD/UNFOLD toggle switch. When you remove pressure from the pendant toggle switch, the operation will stop.

Note: When fully raised, the platform should be unfolded partially before lowering.

Step 6. Pull the platform handle strap to open the platform to full width, and step away from the platform as it opens.

Step 7. To lower the platform, stand to the side clear of the platform and all moving parts, then push the pendant toggle switch down until the platform taper touches the ground. When you remove pressure from the toggle switch, the operation will stop.

Step 8. Finish opening the rear of the van by opening the van's remaining rear door.

Step 9. Unfold the threshold bridges. These bridges provide a transition from the liftgate platform to the van floor.

Step 10. To load the liftgate, center the load on the platform side to side and front to back. Put heavier loads as close to the front of the platform as possible (near truck).

Note: The liftgate capacity depends on both the weight and location of the load. Capacity of the Cantilever Series is based on a load at capacity located 28" back from the platform front (near truck).

Step 11. To raise load, stand off to the side, well clear of the platform and push up on the pendant toggle switch until the load has reached the desired position. Do not allow the pump and motor to continue to run after the platform has reached it's maximum height or after it has reached an obstruction.

Step 12. After completing the loading of the truck, fold the threshold bridges.

Step 13. Lower the platform a few inches to clear the rear van doors, then close the driver side van door.

Step 14. Close and latch the cart stops, if they are raised.

Step 15. With the load removed, raise the platform to the top of its travel and fold the platform in half using the handle strap.

Step 16. To fold the platform up behind the van, push up on the pendant toggle switch while holding either up or down on the FOLD/UNFOLD toggle switch until the platform is tight against the platform stop.

Step 17. Deactivate the pendant control and hang it in the van.

Step 18. Close the rear van door and install the latch pin and padlock.

LEVELING PLATFORM FOR LOADING

1. **Park** the van on a level surface.
2. **Unlock** the platform.
3. **Unfold** the platform completely.
4. **Adjust** the passenger side support arm so that the platform is 1-1/2" from level over a 3 foot length (Figures 3 and 4).
 - a. **Remove** the 1/2" x 3-3/4" bolt and nut.
 - b. **Rotate** the length adjuster in to lower taper or out to raise taper.
 - c. **Reinstall** the 1/2" x 3-3/4" bolt and nut.
5. **Adjust** the driver side support arm so that both support arms carry the platform load equally. Adjustment similar to passenger side.
6. **Verify** that all bolts have been re-installed and tightened.
7. **Close and Lock** the platform.

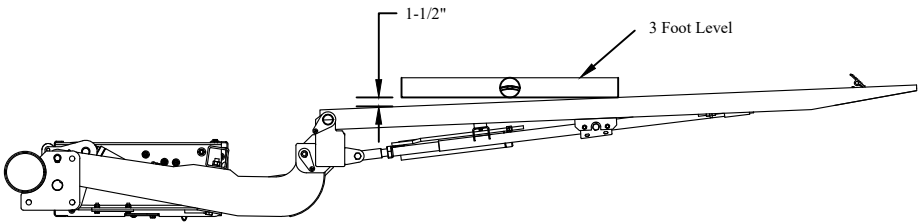

Figure 3: Platform leveling position.

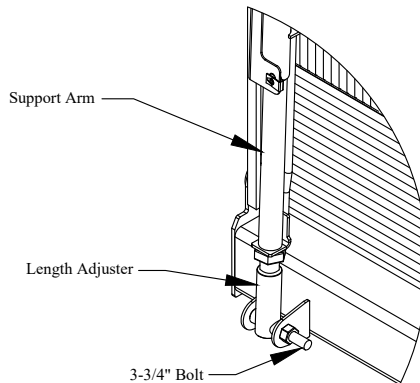

Figure 4: Support arm adjustment.

ADJUSTING PLATFORM TO FOLD CORRECTLY

1. **Park** the van on a level surface.
2. **Verify** that the platform folds to a vertical position without hitting the van door.
3. **Loosen** the 3/8" nuts on the driver side support arm (Figure 5) so they do not contact the stop when the platform is folded.
4. **Support** the platform to keep it from falling or hitting the van in the next step.
5. **Adjust** the fold cylinder for closed/vertical position, if needed (Figure 5).
 - a. **Loosen** the length adjuster jam nut.
 - b. **Remove** the 1/2" x 3-3/4" bolt and nut.
 - c. **Rotate** the length adjuster in to close less or out to close more.
 - d. **Reinstall** the 1/2" x 3-3/4" bolt and nut.
6. **Repeat** step 5 until platform is vertical and can not hit the van door.
7. **Fold** the platform to the vertical position.
8. **Tighten** the lower 3/8" nut on the driver side support arm until it contacts the stop bracket.
9. **Unfold** the platform partially.
10. **Tighten** the lower 3/8" nut on the driver side support arm one additional turn.
11. **Tighten** second 3/8" nut on the driver side support arm against the lower 3/8" nut.
12. **Loosen** the adjustment nuts on the passenger side support arm (Figure 5).
13. **Fold** the platform to the vertical position.
14. **Align** the latch slots/holes on the passenger side support arm.
15. **Insert** the latch pin into the aligned slots/holes on the passenger side support arm.
16. **Tighten** the adjustment nuts on the passenger side support arm.
17. **Verify** that all bolts have been re-installed and tightened, and the jam nut is tight.
18. **Close and Lock** the platform.

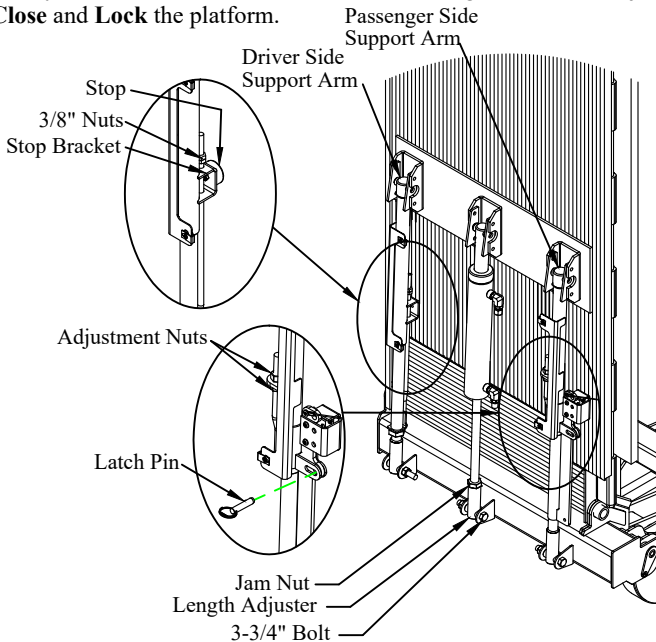

Figure 5: Platform closing adjustment.

USING THE EMERGENCY CHAIN-UP FEATURE

The emergency chain-up feature is used to temporarily hold the lift up if the lift will not raise or will not stay raised. Have the lift repaired before using it in this condition.

1. **Fold** the threshold bridges.
2. **Close** and **latch** the cart stops, if they are raised.
3. **Close** the driver side van door.
4. **Raise** the lift to the top of its travel.

If the lift will not raise on its own, it can be raised with a jack.

!Caution: Do not position yourself under the lift or platform while performing the next step. The lift may drop suddenly when unchained, if not supported. Notify distributor doing the service work that the lift has been chained.

5. **Attach** the emergency chain (Figure 7) to the bolt located in the chain-up channel (Figure 6) of the tension arm. If a jack was used in step 4, it can now be removed.
6. **Fold** the platform in half using the handle strap.
7. **Remove** the 1/2" x 3-3/4" bolt and nut from the fold cylinder length adjuster (Figure 5).
Skip this step if the lift will fold on its own.
8. **Fold** the platform to the vertical position
Be sure to enlist enough personnel to lift the platform, as it will be heavy.
9. **Install** the platform locking pin and padlock.
10. **Deactivate** the pendant control and hang it in the van.
11. **Close** the rear van door.

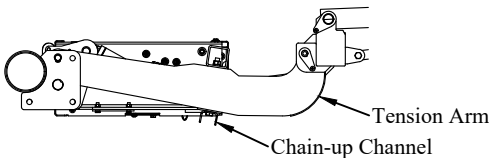

Figure 6: Chain-up channel location.

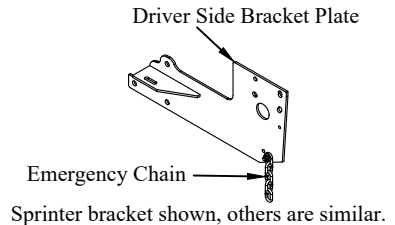

Figure 7: Emergency chain location.

REMOVING THE EMERGENCY CHAIN-UP FEATURE

1. **Support** the platform to keep it from falling in the next step.

!Caution: Do not position yourself under the lift or platform while performing the next steps.

2. **Remove** the padlock and locking pin (Figure 5).
3. **Unfold** the platform manually or hydraulically.
Be sure to enlist enough personnel to manually lower the platform, as it will be heavy.
4. **Apply** pressure with a jack under the tension arm to keep it from dropping in the next step.
5. **Remove** the emergency chain from the chain up channel (Figure 6 and 7).
6. **Repair** the liftgate as needed.

ELECTRICAL WIRING DIAGRAM



WELDING NOTE !!! DISCONNECT ALL BATTERY CABLES. ALWAYS DISCONNECT THE GROUND CABLE FIRST. ATTACH THE WELDING GROUND TO THE TRUCK RATHER THAN THE LIFTGATE.



!!! PLEASE READ AND FOLLOW ALL DIRECTIONS BEFORE PROCEEDING !!!



NOTE !!! IF GATES ARE NOT WIRING IN ACCORDANCE WITH THIS DIAGRAM YOUR WARRANTY WILL BE VOID.

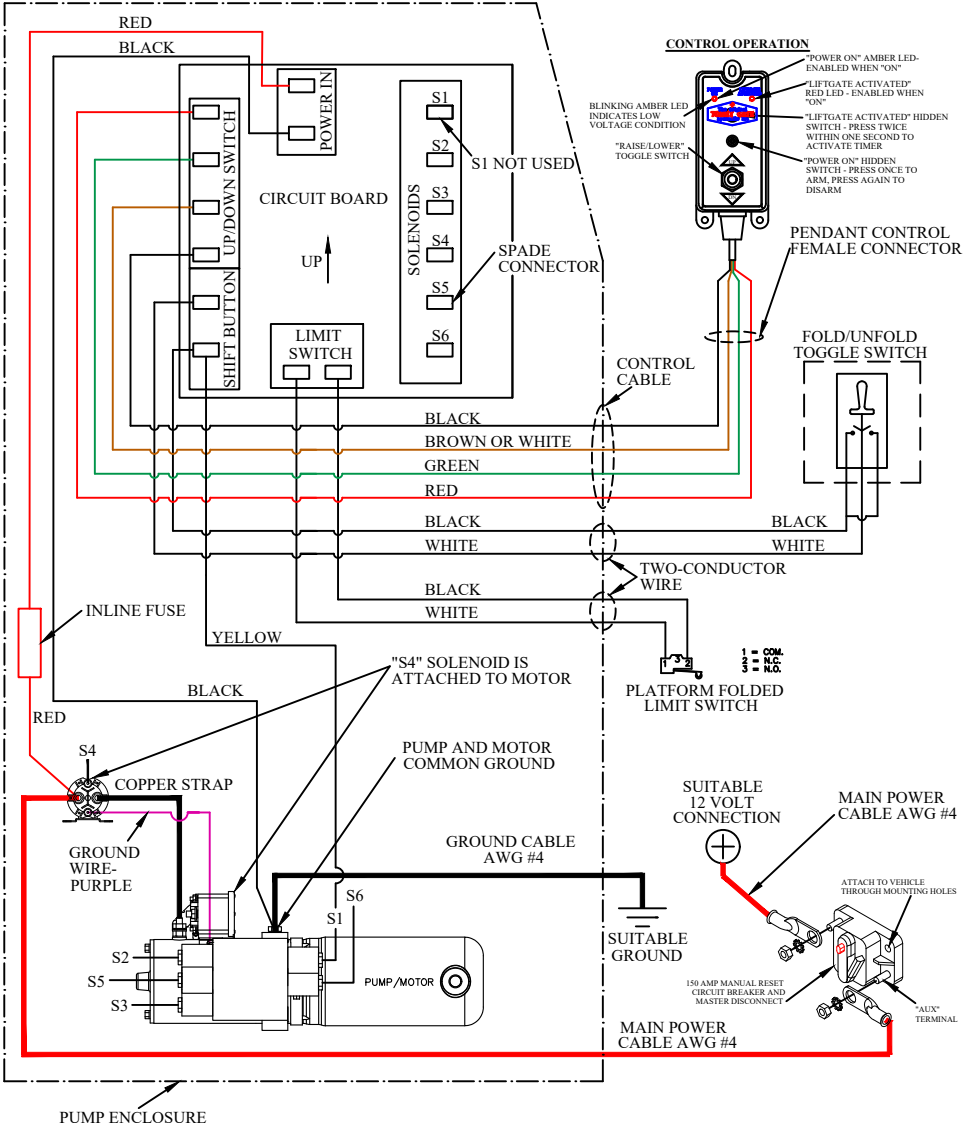
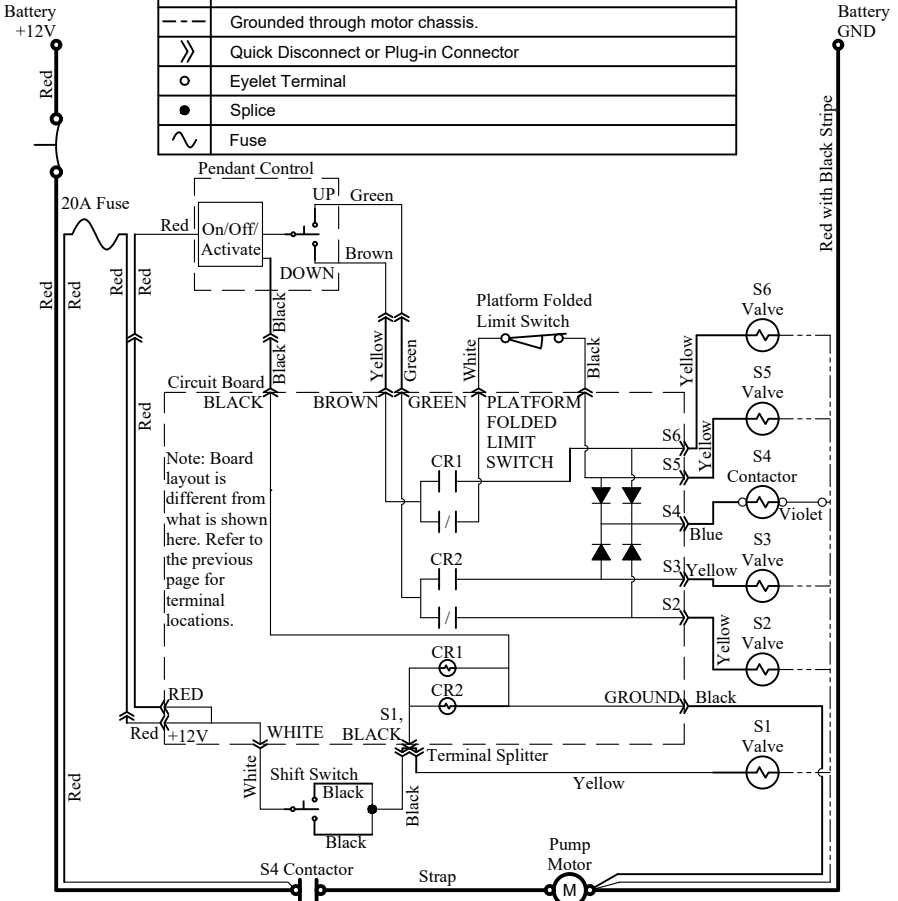

Figure 8: Wiring diagram.

LADDER LOGIC/WIRING DIAGRAM

Ladder Logic/Wiring Diagram

| Legend | |
|--------|--|
| | Circuit Breaker |
| | Toggle Switch |
| | Limit Switch |
| | Relay/Contactor - Normally Open Contacts |
| | Relay/Contactor - Normally Closed Contacts |
| | Motor |
| | Solenoid/Relay/Contactor - Coil |
| | Battery Cable |
| | Wire |
| | Grounded through motor chassis. |
| | Quick Disconnect or Plug-in Connector |
| | Eyelet Terminal |
| | Splice |
| | Fuse |



PENDANT PLUG WIRING DIAGRAM

FEMALE CONNECTOR BACK VIEW
 WIRE INSERTION SIDE

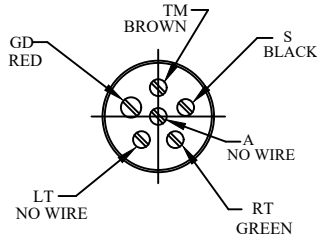

| COLE HERSEE SOCKET END | |
|---------------------------|---------------|
| POSITION | WIRE COLOR |
| S | BLACK |
| RT | GREEN |
| LT | NO WIRE |
| TM | BROWN |
| A | NO WIRE |
| GD | RED |



MAINTENANCE AND SERVICE INFORMATION

All installations, re-installations, and repairs of Tommy Gates should be performed by a qualified authorized distributor that is familiar with its operation and safety features. All replacement parts must be of original quality, and all safety and operational decals must be attached. No modifications are allowed to a Tommy Gate product unless authorized in writing by the Engineering Department at Tommy Gate.

As is with any mechanical product, a preventive maintenance program needs to be followed in order to keep it in its best operating condition. Please review this information and if you should have any questions, please call (712) 847-8000. Please have your model number and serial number available.

The Tommy Gate needs to be serviced every 120 days or 1500-2000 cycles, whichever comes first.

- (A) Check the oil level in the reservoir. With the liftgate platform unfolded and at the bottom of its travel, the fluid reservoir should be one-half full. Add ISO grade 32 hydraulic oil, Dexron or equivalent, if needed.
- (B) Check for leaks from the cylinders, hoses, and all fittings (replace or repair if found to be leaking).
- (C) Replace any worn or missing parts before the liftgate is put back into service.
- (D) If needed, adjust platform latch which is designed to hold the liftgate in a properly stored position.
- (E) Check for cracks in all welds (repair if needed).
- (F) Check for wear at all pivot points.
- (G) Check all electrical connections.(clean or repair if needed)
- (H) Replace fuses, if needed. Check electric cables for worn or damaged insulation.
- (I) Replace or clean safety decals, so that they are legible.
- (J) Check for proper operation of the control.



TROUBLESHOOTING - CANTILEVER SERIES

| PROBLEM | POSSIBLE CAUSE | REMEDIES |
|--|--|---|
| 1.) Lift will not operate-"POWER ON" amber LED light does not come on. | Control not armed properly. | See "Operator's Instructions" on how to activate the control. |
| | Poor electrical connection. | Check and repair or replace all cables and connections. |
| | Polarity is reversed. | Switch positive and negative cables. |
| | Circuit breaker tripped or disengaged. | Check for short, then manually engage circuit breaker. |
| | Inline fuse is blown. | Check for short, then replace fuse. |
| | Faulty control. | Replace control. |
| 2.) Lift will not operate-"LIFTGATE ACTIVATED" red LED light does not come on. | "POWER ON" amber LED light is blinking. | Low voltage condition. Check and repair or replace all cables and connections. |
| | Control not activated properly. | See "Operator's Instructions" on how to activate the control. |
| | Faulty control. | Replace control. |
| 3.) Blinking amber "POWER ON" LED. | Low voltage condition. | Check and clean or repair all electrical connections. Load test battery, then recharge or replace battery, if required. |
| | Poor grounds or connections. | Repair, replace, clean as necessary. |
| | Power connected or reconnected since last use. | Normal, press bullseye once to activate solid "POWER ON" amber LED. |
| 4.) Lift will not raise or raises slowly -control working properly. | Poor electrical connection. | Check power and ground cables and all connections. |
| | Battery charge is low. | Recharge or replace battery. |
| | Release valve stuck, partially open or dirty. | Raise platform completely and continue to run pump for 5 seconds. |
| | Release valve needs replacement. | Contact Tommy Gate or distributor. |
| | "Raise" solenoid not working. | Contact Tommy Gate or distributor. |
| | Oil level low. | Check oil and add ISO grade 32 hydraulic oil, Dexron or equivalent. |
| | Vent plug not installed or dirty. | Check vent plug on pump tank. A red shipping plug is installed at the factory. It must be replaced with a vented plug. |
| | | |
| | Overloaded liftgate. | Remove some material or weight. |



TROUBLESHOOTING - CANTILEVER SERIES

| PROBLEM | POSSIBLE CAUSE | REMEDIES |
|---|---|---|
| 5.) Lift settles down slowly with load or no load. | Hoses or fittings leaking. | Tighten or replace. |
| | Check valve stuck or dirty. | Raise and lower lift several times to flush out valve. |
| | Check valve damaged. | Contact Tommy Gate or distributor. |
| | Cylinder seals worn or damaged. | Contact Tommy Gate or distributor. |
| 6.) Pump or motor noisy. | Down solenoid sticking partially open. | Contact Tommy Gate or distributor. |
| | Worn pump, motor or coupling. | Contact Tommy Gate or distributor. |
| 7.) Lift will not lower. | Oil level low. | Check oil and add ISO grade 32 hydraulic oil, Dexron or equivalent. |
| | Control not armed and activated-No amber "POWER ON" LED or red "LIFTGATE ACTIVATED" LED light on. | See "Operator's Instructions" on how to activate the control. |
| | The limit switch will not allow the platform to be lowered until it is partially unfolded. | This is normal operation, unfold the platform before lowering it. |
| | Platform limit switch or wiring damaged or wired incorrectly. | Wire switch according to the wiring diagram or repair damage. |
| | Poor electrical connections. | Check and clean or repair all electrical connections. |
| | If control is working properly, damaged or non-working release solenoid. | Contact Tommy Gate or distributor. |
| 8.) Lift will not raise or lower, but will fold and unfold | Lifting arms or cylinder pins seized. | Clean and/or replace pins or bushings. |
| | FOLD/UNFOLD toggle switch wired incorrectly. | Wire switch according to the wiring diagram (the wire with one connector must be on the middle terminal). |
| | FOLD/UNFOLD toggle switch bad or wires shorted. | Replace FOLD/UNFOLD toggle switch or repair circuit. |
| | Platform limit switch wired or installed incorrectly or damaged. | Wire switch according to the wiring diagram or replace switch. |
| 9.) Lift will not fold or unfold, but will raise and lower. | FOLD/UNFOLD toggle switch wired incorrectly. | Wire switch according to the wiring diagram (the wire with one connector must be on the middle terminal). |
| | FOLD/UNFOLD toggle switch bad or damaged/cut wire. | Replace FOLD/UNFOLD toggle switch or repair circuit. |
| 10.) Platform will not hold load level (tilts down when loaded) | Platform support arms are not adjusted properly. | Adjust platform support arms so they support the load. The fold cylinder should not support the load. |



WARRANTY GUIDELINES

A. STANDARD WARRANTY

The Tommy Gate Company provides a limited warranty against faulty materials or workmanship. Cantilever Series Tommy Gates are warranted for two (2) full years from the date of user purchase against faulty materials or workmanship.

All affected parts must be returned to the factory prepaid - with full credit issued for those found to be defective. Warranty replacement parts will be shipped from the factory prepaid.

Labor charges to install warranty replacement parts shall be paid in accordance with Tommy Gate's estimated repair time guide and a flat hourly rate established by Tommy Gate. **DEVIATION FROM THE WARRANTY TIMES LISTED MUST BE AUTHORIZED BY TOMMY GATE COMPANY IN ADVANCE.**

The warranty does not include damage resulting from improper installation procedures. Parts must be installed according to Tommy Gate Company's specifications.

Tommy Gate Company will not pay labor for removing other equipment to gain access to Tommy Gate Equipment. Tommy Gate Company will not pay labor for time on the road to and from a service call.

Tommy Gate Company reserves the right to disallow or reduce claims for parts which have been damaged due to misuse, abuse, accidents or improper shipping; or parts which have been incorrectly or unnecessarily replaced.

The warranty is void if the product has been subject to other than normal use. **THERE ARE NO WARRANTIES, EXPRESS OR IMPLIED, INCLUDING THE WARRANTY OF MERCHANTABILITY OR A WARRANTY OF FITNESS FOR A PARTICULAR PURPOSE EXTENDING BEYOND THAT SET FORTH ABOVE.**

B. WARRANTY CLAIMS HANDLING PROCEDURE:

The following procedures are required when an authorized distributor submits a warranty claim for a defective Tommy Gate part:

1. Before any expense is incurred, but after the problem has been diagnosed, the authorized distributor should contact Tommy Gate Company's Warranty Department to discuss the problem and its correction.
2. If it is determined that the condition is potentially covered by Tommy Gate Company's warranty, the authorized distributor will receive instructions on how to proceed. A decision will be made to either repair or replace the product or part in question.
3. If the product or parts are to be repaired, the authorized distributor will receive a **WARRANTY REQUEST NUMBER.**



WARRANTY GUIDELINES

4. If the product or parts are to be replaced, the authorized distributor will be instructed to either hold the parts for inspection by a representative, in which case the authorized distributor will receive a **WARRANTY REQUEST NUMBER**, or the authorized distributor will be asked to return the product for inspection to Tommy Gate Company, in which case the authorized distributor will receive a **RETURN GOODS AUTHORIZATION NUMBER**. Under no circumstances are parts to be returned without a **RETURN GOODS AUTHORIZATION NUMBER**.
5. After the repair or replacement work is completed, the authorized distributor will submit the claim to Tommy Gate Company with the following information:
 - a. Tommy Gate Company **WARRANTY REQUEST** and/or **RETURN GOODS AUTHORIZATION NUMBER**.
 - b. Tommy Gate model number.
 - c. Tommy Gate serial number.
 - d. Tommy Gate part number involved and a description of the apparent problem or defect.
 - e. Authorized distributor performing warranty work.
 - f. Person responsible for warranty work (contact).
 - g. Distributor from whom liftgate was purchased.
 - h. Liftgate owner's name, address, and phone number.
 - i. Action taken, cost involved, complete with work orders and parts expense invoices.
6. If defective parts are to be returned to Tommy Gate Company, the parts:
 - a. Must be packaged for each individual warranty return. No multiple warranty claims in the same box.
 - b. Must be returned "freight prepaid" to Tommy Gate Company's location.
 - c. Must be clearly marked with the **RETURN GOODS AUTHORIZATION NUMBER** on the outside of the package.

Warranty claims must be submitted by the Authorized Distributor on behalf of their customer as part of their customer assistance.

Warranty claim acceptance or rejection is based solely upon defective part inspection and a review of the claim date (outlined in step 5 above) as they apply to the requirements of the Tommy Gate Warranty. Claim reimbursement after acceptance is governed by those allowances previously agreed upon between Tommy Gate Company and the Authorized Distributor (as outlined in steps 1-4 above).

Any warranty claims submitted without a **WARRANTY REQUEST NUMBER** or **RETURN GOODS AUTHORIZATION NUMBER** and the necessary information will be denied.

CANTILEVER SERIES REPAIR PARTS DRAWING

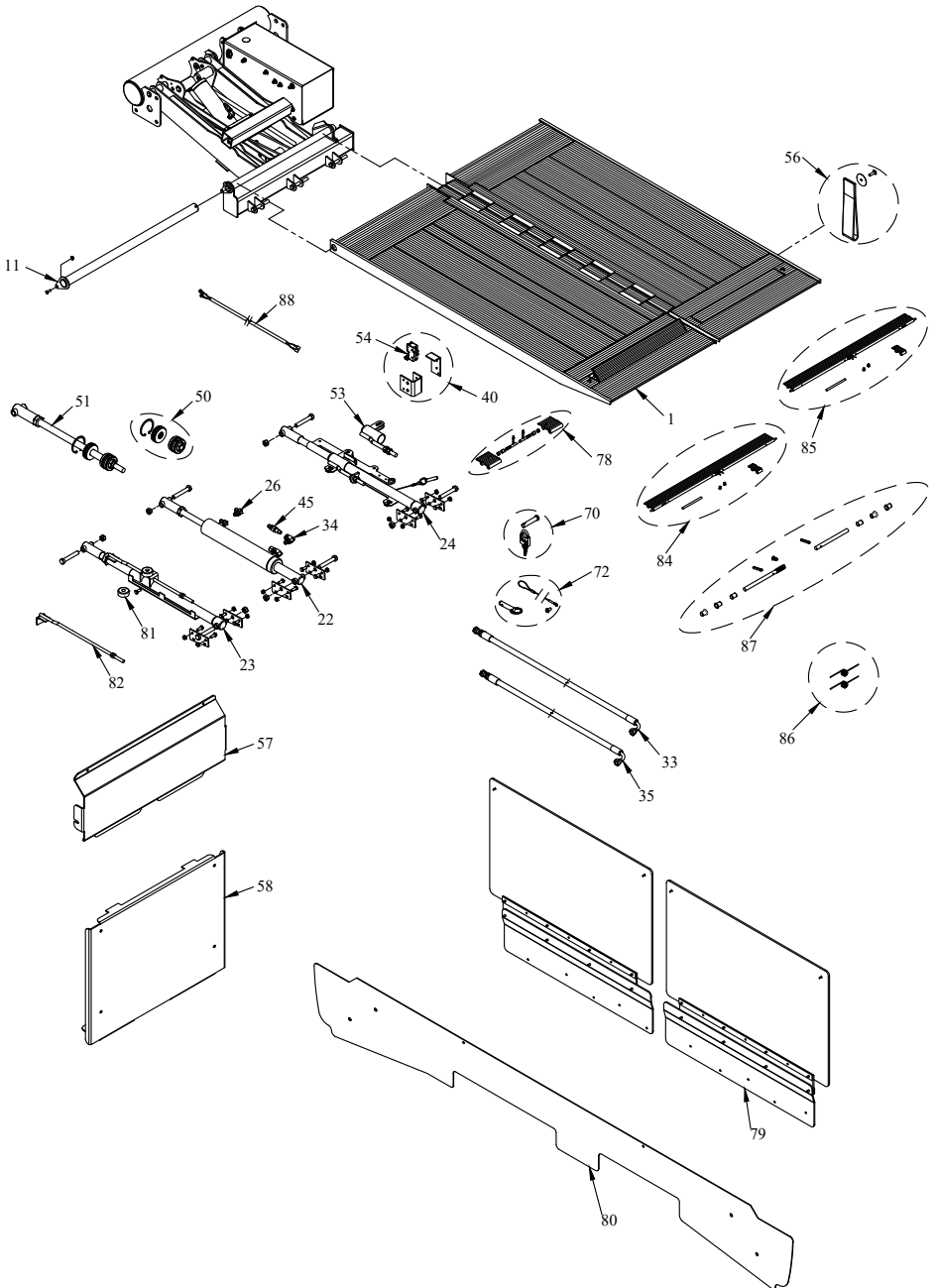

CANTILEVER SERIES REPAIR PARTS DRAWING

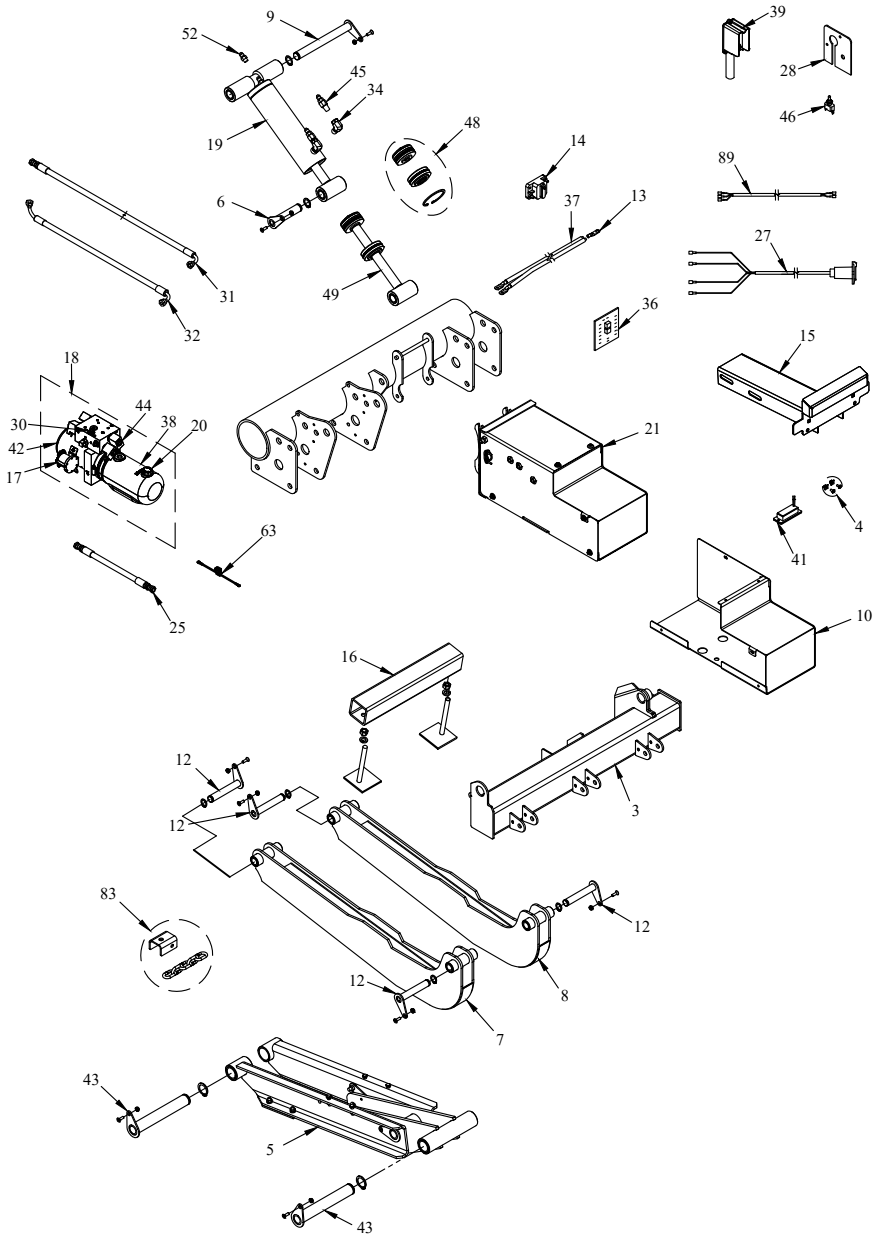



CANTILEVER SERIES REPAIR PARTS LIST

| ITEM# | DESCRIPTION | ITEM# | DESCRIPTION |
|-------|---------------------------------------|-------|----------------------------------|
| 1 | Platform | 38 | Tank |
| 3 | Platform Pivot Sub Assembly | 39 | Timed Control |
| 4 | License Plate Mount Kit | 40 | Limit Switch Kit |
| 5 | Lift Arm w/ Pins & Keepers | 41 | License Plate Light |
| 6 | 7/8" Cylinder Rod Pin w/ Keeper | 42 | Motor Only |
| 7 | Tension Arm w/Pins & Keepers(Left) | 43 | 1-1/4" Lift Arm Pin w/ Keeper |
| 8 | Tension Arm w/Pins & Keepers(Right) | 44 | Release Solenoid |
| 9 | 7/8" Cylinder Base Pin w/ Keeper | 45 | Flow Control |
| 10 | Power Unit Cover | 46 | FOLD/UNFOLD Toggle Switch |
| 11 | Platform Pivot Pin | 48 | Lift Cylinder Seal Repair Kit |
| 12 | 3/4" Tension Arm Pin w/ Keeper | 49 | Lift Cylinder Shaft Kit |
| 13 | Copper Lug | 50 | Fold Cylinder Seal Repair Kit |
| 14 | Manual Reset Circuit Breaker | 51 | Fold Cylinder Shaft Kit |
| 15 | License Plate Bracket w/ Light | 52 | 04MORB-04MJIC Adapter |
| 16 | Stabilizer Tube | 53 | Up Stop Push off Assembly |
| 17 | Raise Solenoid | 54 | Limit Switch |
| 18 | Pump & Motor | 56 | Handle Strap |
| 19 | Lift Cylinder | 57 | Upper Platform Cover |
| 20 | Vent Plug | 58 | Lower Platform Cover |
| 21 | Pump Box | 63 | Control Fuse Holder |
| 22 | Fold/Unfold Cylinder | 70 | Locking Pin and Padlock w/ Keys |
| 23 | Platform Support Arm (Driver Side) | 72 | Latch Pin w/ Lanyard |
| 24 | Platform Support Arm (Passenger Side) | 78 | Cart Stop Latch Kit |
| 25 | Hydraulic Hose-Power Unit | 79 | Bridge |
| 26 | 04MORB x 04MJIC x 90° Cyl. Elbow | 80 | Rear Cover |
| 27 | Pendant Supply Cable | 81 | Driver's Side Support Arm Bumper |
| 28 | Pendant Mounting Bracket | 82 | Up Stop Rod Assembly |
| 30 | Check Valve | 83 | Chain-up Feature |
| 31 | Hydraulic Hose-Lift Cylinder Long | 84 | Primary Cartstop Assembly |
| 32 | Hydraulic Hose-Lift Cylinder Short | 85 | Secondary Cartstop Assembly |
| 33 | Hydraulic Hose-Fold Cylinder Long | 86 | Cartstop Torsion Springs |
| 34 | 04MORB x 04FPT x 90° Cyl. Elbow | 87 | Cartstop Hinge Kit |
| 35 | Hydraulic Hose-Fold Cylinder Short | 88 | Limit Switch Wire Harness |
| 36 | Circuit Board | 89 | Toggle Switch Wire Harness |
| 37 | 4 Ga. 2 Wire Electric Cable | | |

Note:

The item number **is not** the part number. Please have the model number and serial number available before calling for repair parts.



THIS PAGE
INTENTIONALLY LEFT
BLANK



THIS PAGE
INTENTIONALLY LEFT
BLANK



**America's First Name
in Liftgates[™]**

Manufacturing Plant:
83 Bus Brown Drive
Woodbine, Iowa 51579
FAX (712) 647-2417

Corporate Offices:
33717 N. Scottsdale Rd. Ste 120
Scottsdale, AZ 85266
FAX (602) 955-3902

(712) 847-8000
www.tommygate.com

